

A Turning Drehen A1-A310	General Turning Allgemeine Drehbearbeitung	A 1 - A 253
	Parting and Grooving Ab- und Einstechen	A 254 - A 290
	Thread Turning Gewindedrehen	A 291 - A 323
B Milling Fräsen B1-B290	Milling Indexable Tools Fräsen - WSP· Werkzeuge	B 1 - B 187
	Milling - Solid Carbide Endmills Fräsen VHM - Schafffräser	B 188 - B 374
C Drilling Bohren C1-C147	Drilling - Solid Carbide Drills Bohren - VHM Bohrer	C 6 - C 93
	Drilling Indexable Tools Bohren - WSP· Werkzeuge	C 95 - C 105
Reaming Reiben	Reaming Reiben	C 106 - C 116
Threading Gewinde	Threading - Solid Carbide Tools Gewinde - VHM Gewindebohrer	C 118 - C 124
	Solid carbide Threading end mills Gewindefräsen - VHM Gewindefräser	C 125 - C 128
D	Tooling Systems Werkzeugsysteme	D 1 - D 38
E	General Technical Information Allgemeine Technische Informationen	E 1 - E 20
Index		01 - 03



Turning · Drehen

Turning Insert (Overview)
Turning Tools (Overview)
Recommended Grades for Turning

A4-A9
A10-A13
A14

Schneidplatten zum Drehen (Übersicht)
Halter zum Drehen (Übersicht)
Empfohlene Sorten für die
Drehbearbeitung

Chip breaker Overview and Description
Grade Description
ISO indexable insert code key
Application instruction of general turning

A16-30
A31-40
A42-43
A44-A45

Spanbrecher Übersicht und Beschreibung
Sortenbeschreibung
ISO Kennzeichnung für Schneidplatten
Allgemeine Anwendungsempfehlung
(Drehen)

ISO Turning Inserts
Carbide and Cermet Inserts
PCBN & PCD Inserts
Ceramic Insert

A46-A146
A46-A112
A113-A135
A136-A146

ISO Wendeschneidplatten zum Drehen
Hartmetall und Cermet WSP
PCBN & PKD Wendeschneidplatten
Keramik Wendeschneidplatten

Turning Tool Holder
External Turning Tools
Internal Turning Tools
Recommended cutting parameters

A147-A253
A147-A210
A211-A248
A249-A253

Drehwerkzeuge
Halter für **Außenbearbeitung**
Halter für **Innenbearbeitung**
Empfohlene Schnittdaten (Drehen)

Parting, Grooving Tools
Parting, Grooving Tool (Overview)
ISO Parting, Grooving insert code key
Parting, Grooving Inserts
Parting, Grooving Holder
Parting, Grooving Cutting Condition

A254-A290
A255-A259
A260
A261-A268
A269-A288
A289-A290

Ab- und Einstech-Werkzeuge
Ab- und Einstechen (Übersicht)
ISO Kennzeichnung für Stechplatten
WSP zum Ab- und Einstechen
Halter zum Ab- und Einstechen
Ab- und Einstechen Schnittdatenempfehlung

Threading Tools
Threading Tools (Overview)
ISO Threading inserts code key
Threading Inserts
ISO tools code key
Threading Cutting Conditions

A291-A316
A292-A294
A295
A296-A302
A303
A304-A305

Gewindedreh-Werkzeuge
Klemmhalter zum Gewindedrehen (Übersicht)
ISO Kennzeichnung für Gewindeplatten
Gewindedrehplatten
ISO Kennzeichnung für Gewindehalter
Gewindedrehen
Schnittdatenempfehlung
Empfohlene Schnittdaten (Gewindebearb.)

Recommend Cutting datas

A306-A316

General Technical Info. for Turning

A317-323

























Allgemeine Technische Info. zum Drehen

Turning · Drehen

Turning Inserts Overview · WSP Übersicht

Carbide and Cermet Inserts - Hartmetall- und Cermet-WSP















Finishing · Schlichten

									Edge length · Kantenlänge Page · Seite
CNMG-DF	CNMG-SF	CNMG-EF	CNEG-NF	DNMG-DF	DNMG-FM	DNMG-SF	DNMG-EF	DNEG-NF	
09,12	09,12	09,12	12	11,15	15	11,15	11,15	15	
A46	A46	A46	A47	A53	A54	A53	A54	A54	
									Edge length · Kantenlänge Page · Seite
SNMG-DF	SNMG-EF	SNMG-SF	TNMG-DF	TNMG-FM	TNMG-SF	TNMG-EF			
09,12	09,12,15	09,12,15	16,22	16	11,16,22	11,16,22			
A59	A59	A60	A68	A69	A68	A68			
									Edge length · Kantenlänge Page · Seite
VNMG-DF	VNMG-EF	VNEG-NF	VNMG-SF	WNMG-DF	WNMG-SF	WNMG-EF	WNEG-NF		
16	16	16	16	06,08	06,08	06,08	08		
A74	A74	A74	A74	A76	A77	A77	A77		

Wiper

				Edge length · Kantenlänge Page · Seite
CNMG-WG	DNMX-WG	TNMX-WG	WNMG-WG	
12,16	11,15	16	06,08	
A46	A53	A68	A76	

Medium Cutting · Mittlere Bearbeitung

					Edge length · Kantenlänge Page · Seite
CNMG-PM	CNMG-DM	CNMG-EM	CNMG-NM	CNMG	
09,12,16,19	09,12,16,19	12,16	12	12,16,19	
A47	A48	A48	A49	A51	
					Edge length · Kantenlänge Page · Seite
DNMG-PM	DNMG-DM	DNMG-EM	DNMG-NM	DNMG	
11,15	11,15	11,15	15	15,19	
A54-A55	A55	A56	A56	A58	
					Edge length · Kantenlänge Page · Seite
SNMG-PM	SNMG-DM	SNMG-EM	SNMG-NM	SNMG	
09,12,15,19	09,12,15,19	12,15	12	09,12,15,19,25	
A60	A61	A61	A62	A65	

Double Side Negative Inserts
Doppelseitige negative Platten

Medium Cutting · Mittlere Bearbeitung

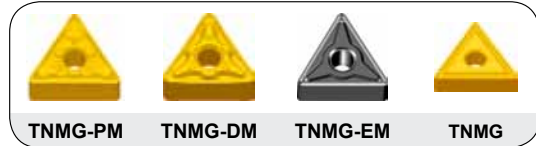

TNMG-PM	TNMG-DM	TNMG-EM	TNMG
11,16,22	11,16,22	16,22	11,16,22,27,33
A69	A69	A70	A72

Edge length ·
Kantenlänge
Page ·
Seite



VNMG-PM	VNMG-DM	VNMG-EM	VNMG-NM	VNMG
16	16	16	16	16
A75	A75	A75	A75	A75

Edge length ·
Kantenlänge
Page ·
Seite



WNMG-PM	WNMG-DM	WNMG-EM	WNMG-NM	RNMG
06,08	06,08	06,08	08	12
A78	A78	A78	A79	A80

Edge length ·
Kantenlänge
Page ·
Seite

Medium to Rough Cutting · Mittlere bis Schruppbearbeitung

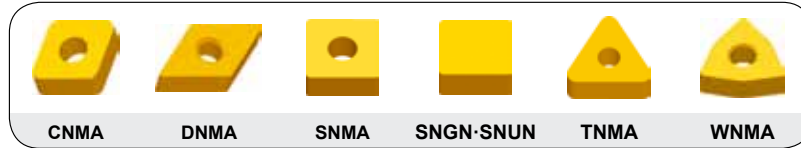

CNMA	DNMA	SNMA	SNGN-SNUN	TNMA	WNMA
12,16,19	11,15	09,12,15,19	09,12,15,19,25	16,22,27	06,08
A51	A57	A66	A67	A73	A79

Edge length ·
Kantenlänge
Page ·
Seite

Roughing · Schruppen



CNMG-DR	CNMG-ER	DNMG-DR	DNMG-ER	SNMG-DR	SNMG-ER	TNMG-DR	TNMG-ER
12,16,19	12,16,19	15	15	12,15,19	12,15,19	16,22,27	16,22
A49	A50	A56	A58	A62	A63	A70	A71



WNMG-DR
06,08
A79

Edge length ·
Kantenlänge
Page ·
Seite

Roughing · Schruppen



CNMM-DR	CNMM-ER	CNMM-HDR	CNMM	DNMM-DR	DNMM-ER	DNMM-HDR
12,16,19,25	25	12,16,19	12,19	15	15	15
A50	A50	A50	A52	A58	A58	A58

Edge length ·
Kantenlänge
Page ·
Seite

Double Side Negative Inserts
Doppelseitige negative Platten

Single Side Negative Inserts
Einseitige Negative Platten

General Turning · Allgemeine Drehbearbeitung

Turning · Drehen

Turning Inserts Overview · WSP Übersicht

Single Side Negative Inserts
Einseitige Negative Platten

Roughing · Schruppen

SNMM-DR	SNMM-ER	SNMM-HDR	SNMM	TNMM-DR	TNMM-HDR	TNMM
12,15,19,25	25	12,15,19,25	09,12,19,25	16,22,27	16,22,27	16,22,27
A62-A63	A63	A64	A65-66	A71	A72	A73

Edge length ·
Kantelänge
Page ·
Seite

Special Inserts
Spezielle Drehplatten

Roughing · Schruppen

175.32-28	175.32-22-227	175.32-24	175.32-25	KNUX	TNMX	YNMX-YNUX
19	19	19,30	19	16	11,15	18,25
A82	A82	A82	A82	A81	A83	A83

Edge length ·
Kantelänge
Page ·
Seite

Single Side Positive Inserts
Einseitige positive Wendschneidplatten

Fine Finishing · Feinstbearbeitung

CCGT-SF	DCGT-SF	TCGT-SF	VCGT-SF	VBGT-SF	CPGT-SF	DPGT-SF	TPGT-SF
06,09	07,11	06,09,11	11,16	11	06,09	07,11	09,11
A84	A88	A98	A106	A108	A87	A91	A103

Edge length ·
Kantelänge
Page ·
Seite

TBGH-L	TPGH-L
06	09,11
A97	A103

Edge length ·
Kantelänge
Page ·
Seite

Finishing · Schlichten

CCMT-HF	CCMT-EF	CPGT	DCMT-HF	DCMT-EF	SCMT-HF	SCMT-EF	TCMT-HF
06,09,12	06,09,12	05	07,11	07,11	09	09	06,09,11,16
A84	A85	A84	A88	A89	A94	A94	A99

Edge length ·
Kantelänge
Page ·
Seite

TCMT-EF	VCGT	VCGT-HF	VCGT-NF	VBMT-HF	VBMT-EF	VBMT-53	VBET-NF
09,11,16	13	11	16	11	11,16	16	16
A100	A106	A106	A106	A108	A108	A108	A108





Edge length ·
Kantelänge
Page ·
Seite

Medium Cutting · Mittlere Bearbeitung

CCMT-HM	CCMT-EM	DCMT-HM	DCMT-EM	SCMT-HM	SCMT-EM	TCMT-HM	VCMT-EM
06,09,12	06,09,12	07,11	07,11	09,12	09,12	09,11,16	16
A85	A85	A89	A89	A94	A94	A101	A110

Edge length ·
Kantelänge
Page ·
Seite

Roughing · Schruppen







				
CCMT-HR	DCMT-HR	SCMT-HR	TCMT-HR	VBMT-HR
06,09,12	11	09,12	09,11,16,22	16
A86	A90	A95	A101	A109
Edge length · Kantenlänge				
Page · Seite				

Flat Inserts · WSP ohne Spanbrecher



						
CCMW	DCMW	SCMW	TCMW	VBMW	CPGW	DPMW
06,09,12	07,11	06,09,12	11,16,22	16	06	11
A86	A90	A95	A102	A109	A87	A91
Edge length · Kantenlänge						
Page · Seite						

			
SPMW	TPGA	TPGB	TPGW
09,12	09,11,16	09,27	09,11,16,22
A96	A104	A105	A105
Edge length · Kantenlänge			
Page · Seite			

Aluminium machining · Aluminiumbearbeitung

					
CCGX-LH	DCGX-LH	RCGX-LH	SCGX-LH	TCGX-LH	VCGX-LH
06,09,12	07,11	08	09,12	09,11,16	11,16,22
A86	A90	A92	A95	A101	A107
Edge length · Kantenlänge					
Page · Seite					

Special Inserts · Spezielle Wendeschneidplatten





				
RCM(GT)	RCMX	SCMT	TCMT	WCMX-53
08,10,12,16,19	08,10,12,16,20,25,32	09,12	22	04,06,08
A92	A93	A95	A102	A111
Edge length · Kantenlänge				
Page · Seite				

Turning · Drehen

Turning Inserts Overview · WSP Übersicht

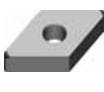

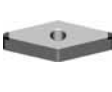
Negative Inserts
Negative WSP

PCBN & PCD

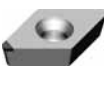

					
CNGA	DNGA	SNGA	TNGA	VNGA	WNGA
12	15	12	16	16	08 16
A118	A119	A120	A121	A122	A122

Edge length ·
Kantelänge
Page ·
Seite

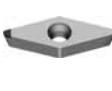
Positive Inserts
Positive WSP

				
CCGW	DCGW	TCGW	VBGW	VCGW
06,09,12	07,11	11,16	16	16
A123	A124	A125	A126	A126

Edge length ·
Kantelänge
Page ·
Seite

				
CCMT	CCMW	DCMT	DCMW	TCMT
06,09,12	06,09,12	07,11	07,11	11,16
A127	A128	A129	A130	A131









Edge length ·
Kantelänge
Page ·
Seite

				
TCMW	VBMT	VBMW	VCMT	VCMW
11,16	16	16	16	16
A132	A133	A133	A134	A134





Edge length ·
Kantelänge
Page ·
Seite

Ceramic Inserts · Keramik Wendeschneidplatten

Negative Inserts
Negative WSP

							
CNGA	CNGN	CNGX	DNGA	DNGN	DNGX	SNGA	SNGX
12,16	12,16	12	15	15	15	12	12
A138	A139	A140	A140	A141	A141	A142	A142

Edge length ·
Kantelänge
Page ·
Seite







				
SNGN	TNGA	TNGN	WNGA	RNGN
09,12,15,19,25	16,22	16,22	08	09,12,15,19,25
A143	A144	A145	A146	A146

Edge length ·
Kantelänge
Page ·
Seite



Parting and grooving · Ab- und Einstechen

Little Squirrel Series · zusätzliche Wendeschneidplatten







							
ZPD-MG	ZP□D-MG	ZP□S-MG	ZT□D-MG	ZTBD-MG	ZT□S-MG	ZT□D-EG	
2.5,3,4,5,6	2.5,3	2.5,3,4,5,6	2.5,3,4,5,6	2	5,6	1-2.4	Width · Breite
A261	A262	A261	A263	A262	A263	A263	Page · Seite

						
ZT□D-EG	ZIMF-NM	ZR□D-MG	ZR□D-EG	ZIGQ-NM	ZR□D-LH	
2.4-6.5	3,4,5,6	2.5,3,4,5,6	3,4,5,6	3,4,5,6	6,8	Width · Breite
A263	A265	A264	A264	A266	A266	Page · Seite

Complementary Inserts · ergänzende Stechplatten

			
154.3	ZQMX-1E	ZSM□R/L	
1.1,1.3,1.6,1.85,2.15,3.15	3.125,4.125,5.125,6.4,7.05	1.1,1.3,1.6,1.85,2.15,2.65,5.5,15	Width · Breite
A267	A267	A268	Page · Seite

Threading Insert · Gewindeplatten

ISO metric ISO metrisch		Partial-Profile 60°·55° Teil-Profil 60°·55°		Whitworth Rohrgewinde		
						
External thread Außengewinde	Internal thread Innengewinde	External thread Außengewinde	Internal thread Innengewinde	External thread Außengewinde	Internal thread Innengewinde	
1~6	1~6	0.5~5	0.5~5	8~16	8~16	Pitch · Steigung
A296	A297	A298	A298	A299	A299	Page · Seite







UN Unified Conventional Thread Gewindeform UN 60°amerikanisch		BSPT Britain Standard Taper Pipe Thread Rohrgewinde für Dampf-, Gas-, & Wasserleitungen		NPT American Standard Amerikanisches kegeliges Rohrgewinde		
						
External Threads Außengewinde	Internal Threads Innengewinde	External Threads Außengewinde	Internal Threads Innengewinde	External Threads Außengewinde	Internal Threads Innengewinde	
8~20	8~20	11~28	11~28	8~27	8~27	Pitch · Steigung
A300	A300	A301	A301	A302	A302	Page · Seite

Illustration Shows the right hand type · Die Illustration zeigt die Rechtsausführung.

Turning · Drehen

Turning Toolholder Overview · Halter zum Drehen Übersicht

External Turning Holder · Halter zur Außenbearbeitung

P-type Clamping (lever) · P Halter (Kniehebel)



Angle-Winkel	75°	95°	93°	63°	75°	45°	75°
Page-Seite	A158	A159	A160	A161	A162	A163	A164



Angle-Winkel	45°	90°	60°	90°	95°
Page-Seite	A165	A166	A167	A168	A169

M-type Clamping (clamping finger) · M Halter (Pratze)



Angle-Winkel	75°	95°	93°	62°30'	75°	75°	75°
Page-Seite	A170	A171	A172	A173	A174	A175	A176



Angle-Winkel	45°	90°	93°	90°	72°30'	93°	95°
Page-Seite	A177	A178	A179	A180	A181	A182	A183



Angle-Winkel		
Page-Seite	A184	A184

S-type Clamping (screw) · S Halter (Schraube)



Angle-Winkel	90°	95°	90°	93°	62°30'	93°	90°
Page-Seite	A185	A186	A187	A188	A189	A190	A191



Angle-Winkel	72°30'	72°30'	93°	75°	45°	75°	45°
Page-Seite	A192	A193	A194	A195	A195	A196	A196



■ S-type Clamping (screw) · S Halter (Schraube)

							
Angle-Winkel Page-Seite	90° A197	91° A197	91° A198	60° A199	90° A200	90° A201	90° A202

■ C-type Clamping (clamping finger) · M Halter (Pratze)

		
Angle-Winkel Page-Seite	93° A203	63° A203

■ Tool holder for ceramic inserts · Halter für Keramikplatten

							
Angle-Winkel Page-Seite	95° A204	93° A204	93° A205	93° A205	75° A206	75° A206	45° A207
							
Angle-Winkel Page-Seite	45° A207	95° A208	93° A208	45° A209			

Tool holder for Internal Machining · Halter zur Innenbearbeitung

P-type Clamping (lever) · P Halter (Kniehebel)

					
Angle- Winkel 95°	62°30'	93°	75°	90°	95°
Page- Seite A216	A218	A219	A221	A222	A223

S-type Clamping (screw) · S Halter (Schraube)

						
Angle- Winkel 95°	107°30'	93°	85°	75°	90°	107°30'
Page- Seite A224	A226	A227	A228	A229	A230	A231

						
Angle- Winkel 93°	107°30'	93°	95°	107°30'	93°	93°
Page- Seite A232	A233	A234	A235	A236	A237	A238

	
Angle- Winkel 90°	95°
Page- Seite A239	A240

Carbide boring bars · Hartmetallbohrstangen

					
Angle- Winkel 95°	107°30'	93°	93°	107°30'	93°
Page- Seite A242	A243	A244	A245	A247	A248

Tool Holder for Parting & Grooving · Halter zum Ab- und Einstechen

 QE**R/L	 QEBDR/L	 QECDR/L	 QX*DR/L	 QE*SR/L	 QE*S**N	 QZS*
A272	A271	A273	A273	A274	A275	A275
 QF**R/L RR/LL	 QF*DR/L	 C***-Q*DR/L	 C16M-QBDR/L	 C40X-Q*DR/L	 QZQ**R/L	 C***QZSR
A278-A281	A282-A283	A284	A271	A284	A286	A287
 QZS**R/L	 QT**R/L					
A287	A288					

Tool Holder for Threading · Halter für Gewindebearbeitung

 SWR/L	 SNR/L
A304	A305

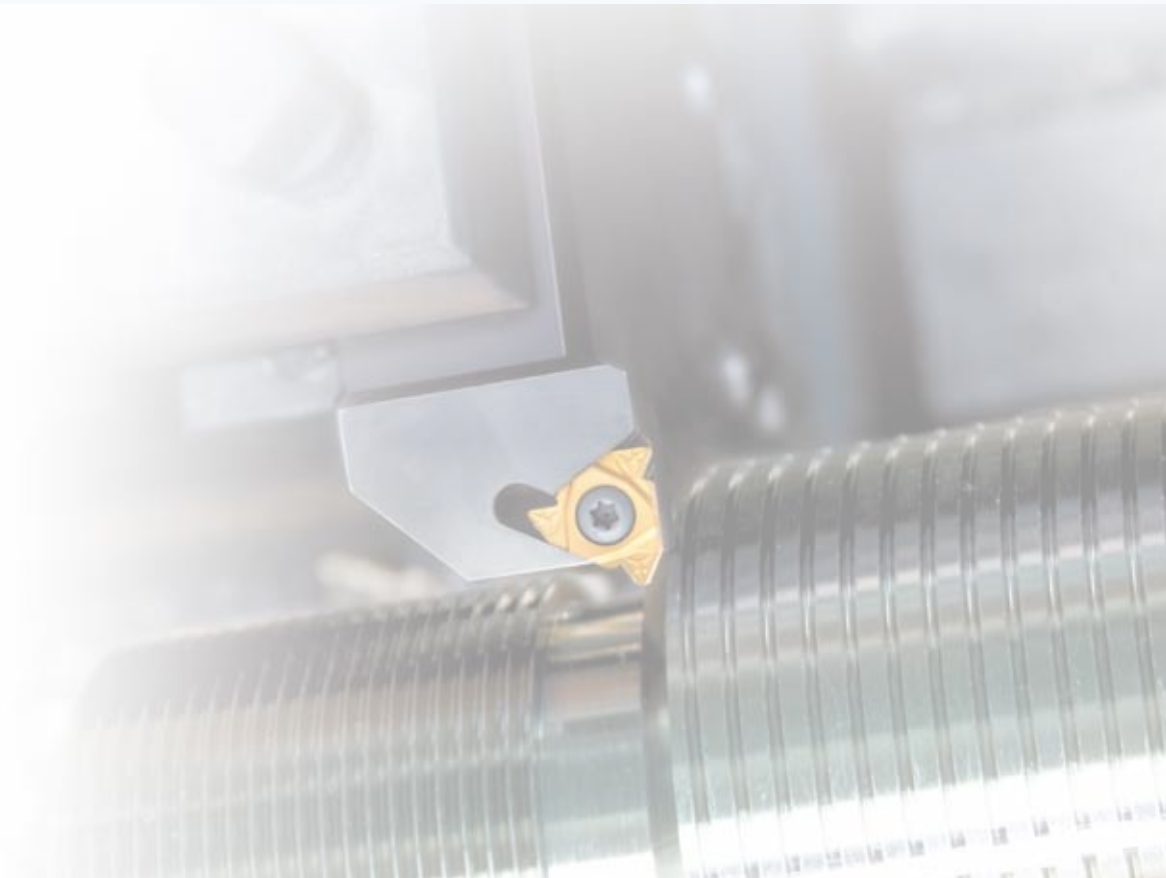

Turning · Drehen

Recommended Grade Overview (Inserts) · Empfohlene Sorten Übersicht (WSP)

ISO		General Turning · Allgemeine Drehbearbeitung										Threading Gewinde	Parting and Grooving Ab- und Einstechen			
Code	Coating · beschichtet	CVD		PVD		Cermet unbeschichtet	Cermet beschichtet	Ceramic Keramik	cemented carbide Hartmetall	PCBN	PCD	Coated beschichtet	Coated · beschichtet		cemented carbide Hartmetall	
		PVD		PVD	CVD							PVD				
P Steel · Stahl	01															
	10	YBC151			YBG102		YNG151									
	20	YBC251			YBG202		YNG151C		CA1000		YC10		YBG201		YBC251	YBG202
	30		YBC351		YBG205						YC40					YBG302
	40				YBG302											
M Stainless Steel · Rostfreier Stahl	01															
	10	YBM151			YBG202		YNG151C									
	20	YBM251			YBG205								YBG201		YBG202	
	30	YBM351			YBG302										YBG302	
	40															
K Cast iron · Gusseisen	01															
	10	YBD052	YBD102	YBD152	YBD151		YNG151		CN1000	CA1000	YD051	YCB211	YCB011			
	20				YBD252		YNG151C		CN2000	CA1000	YD201				YBG302	YD201
	30												YBG201			
	40															
N Non-ferrous materials NE Metalle	01															
	10												YCD421	YCD011		
	20												YBG201			YD201
	30															
	40															
S Heat-resistant steel Superlegierungen	01															
	10				YBG102						YD101					
	20				YBG202								YBG201		YBG102	YBG302
	30															YD201
	40															
H super Hard Material Gehärtete Werkstoffe	01											YCB121	YCB111			
	10											YCB012				
	20															
	30															
	40											YCB131				

- P** Steel / Stahl
- M** Stainless Steel / Rostfreier Stahl
- K** Cast iron / Gusseisen

- N** Non-ferrous materials · Ne Metalle
- S** Heat-resistant steel · Warmfester Stahl
- H** Hardened material · Gehärtete Werkstoffe

General Turning Inserts · Allgemeine Drehschneidplatten

A16 - A23	ISO Turning Inserts Chip breaker Description ISO WSP Spanbrecherbeschreibung
A24-A30	ISO Turning Chip breaker application Guide ISO Spanbrecher nach Anwendungsbereichen
A31-A40	ISO Turning Grades application Guide ISO Sorten nach Anwendungsbereichen
A41-A146	ISO Turning Inserts ISO Wendeschneidplatten
A42-A43	ISO indexable inserts code key ISO Kennzeichnung für Schneidplatten
A44-A45	Metric and Britain System Comparison List Of General Turning Insert Vergleich Metrisch-Britisch WSP Code
A46-A112	Carbide, Cermet Inserts Hartmetall, Cermet WSP
A46-A83	Negative Inserts Carbide and Ceramic Negative Wendeschneidplatten Hartmetall und Keramik
A84-A112	Positive Inserts Carbide and Ceramic Positive Wendeschneidplatten Hartmetall und Keramik
A113-A134	PCBN & PCD Insert Identification Table PCBN & PKD Schneidplattenbezeichnung
A114-A115	PCBN & PCD ISO inserts code key PCBN & PKD ISO Kennzeichnung für Schneidplatten
A116-A117	PCBN & PCD Insert Specificaiton List PCBN & PKD Zuordnungsübersicht
A118-A134	Negative and Positive Inserts PCBN & PCD Negative und Positive Wendeschneidplatten PCBN & PKD
A135	PCBN Grade Trouble Shooting PCBN Sorten Problembhebung
A136-A137	Ceramic ISO inserts code key Keramik ISO Kennzeichnung für Schneidplatten
A138-A146	Ceramic Inserts Keramik Wendeschneidplatten

Chip breaker Overview · Spanbrecher Übersicht

Negative Inserts
Negative Wendeschneidplatten

NEU

P M K

ap·d.o.c. =0.05~1,5(mm)
f=0.05~0.35(mm/r)



NEW

Special chip breaker in combination with cermet grades. Sharp cutting edge with excellent chip control at small depth of cut and small feed rate. Enable high surface finishing.

Spezieller Spanbrecher in Kombination mit Cermetsorten. Mit scharfer Schneide für exzellenten Spanbruch bei kleinen Schnitttiefen und Vorschüben und sehr guter Oberflächengüte.

SF

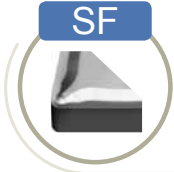

P M

ap·d.o.c. =0.3~2,5 (mm)
f=0.05~0.35(mm/r)



Chip breaker for finishing and semi-finishing of steel and stainless steel.

Spanbrecher für die Schlicht- bis mittlere Bearbeitung von Stahl und rostfreiem Stahl.

DF



M S

ap·d.o.c. =0.05~2,5(mm)
f=0.05~0.3 (mm/r)



Sharp, positive cutting edge for finishing and semi-finishing of austenitic stainless steel, soft steel, low carbon steel and heat resistant super alloy. Suitable for continuous to light interrupted cut.

Sehr scharfe und positive Schneidkante für die Schlicht- bis mittlere Bearbeitung von austenitischem, rostfreiem Stahl, weichem Baustahl und Stahl mit niedrigem Kohlenstoffgehalt und warmfesten Superlegierungen.

EF



S M

ap· d.o.c. =0.1~1,5(mm)
f=0.05~0.3(mm/r)



Ground inserts with sharp and positive cutting edge. NF with grade YBG102 is best combination for finishing of heat resistant super alloys (Ni-based, Fe-based and Co-based alloys) Vc=40-100m/min

Geschliffene Wendeschneidplatte mit einer scharfen, positiven Schneidkante. NF in Kombination mit der Sorte YBG102 ist die beste Lösung für die Schlichtbearbeitung von warmfesten Superlegierungen und exotischen Materialien (Ni-basiert, Fe-basiert, Co-basiert) Vc=40-100m/min

NF

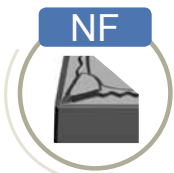

Schlichten · Finishing

General Turning · Allgemeine Drehbearbeitung

Chip breaker Overview · Spanbrecher Übersicht

Wiper



P M K
 ap· d.o.c. =0.3~2(mm)
 f= 0.1~0.4(mm/r)



Excellent surface finishing and high feed rate due to wiper technology. For finishing and semi-finishing of steel, stainless steel or cast iron.

Exzellente Oberflächengüte und hohe Vorschübe durch Wipertechnologie. Geeignet zum Schlichten bis mittlere Bearbeitung von Stahl, rostfreiem Stahl und Guss.

Mittlere Bearbeitung · Semi-Finishing



P M
 ap· d.o.c. =1.5~5(mm)
 f= 0.15~0.5(mm/r)



Main chip breaker for medium machining with continuous or interrupted cut of steel and stainless steel.

Hauptspanbrecher für die mittlere Bearbeitung mit und ohne Schnittunterbrechung von Stahl und rostfreiem Stahl.



P K
 ap· d.o.c. =1.5~5(mm)
 f= 0.15~0.5(mm/r)



Unisversal chip breaker with stable cutting edge. Suitable for medium machining also with interrupted cut especially for cast iron and steel.

Universelle Spanbrecherform mit stabiler Schneidkante. Besonders geeignet für die mittlere Bearbeitung von Guss und Stahl auch mit Schnittunterbrechung.

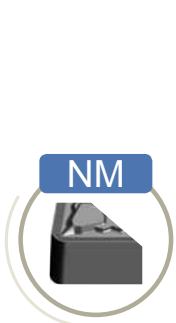

S M
 ap· d.o.c. = 1.5~5(mm)
 f= 0.15~0.5(mm/r)



Sharp cutting edge with positive multi-rakes. Special for the semifinishing of heat resistant super alloys.

Scharfe Schneidkante mit positivem Multi-Spanwinkel. Besonders geeignet für die Bearbeitung von wärmfesten Superlegierungen.



M P S
 ap· d.o.c. =0.5~4.0(mm)
 f=0.1~0.5(mm/r)



Sharp and stable cutting edge for semifinishing of adhesive material and austenitic stainless steel. Suitable also for interrupted cut.

Spanbrecher mit scharfer, stabiler Scheidkante für die mittlere Bearbeitung von adhäsiven Materialien und austenitischem rostfreiem Stahl. Auch für Schnittunterbrechungen geeignet.

Chip breaker Overview · Spanbrecher Übersicht

Mittlere Bearbeitung · Semi-Finishing

Negative Inserts
Negative Wendeschneidplatten

Basic



P K

ap· d.o.c. = 1.5~5(mm)
f = 0.2~0.5(mm/r)



Stable flat cutting edge with standard chip breaker for semifinishing of steel and cast iron.

Stabile gerade Schneidkante mit umlaufender Spanleitstufe für die mittlere Bearbeitung von Stahl und Gusswerkstoffen.

P K

double side ap· d.o.c. = 2.0~6.5(mm)
f = 0.2~0.5(mm/r)
single side ap· d.o.c. = 3~15(mm)
f = 0.4~1.0 (mm/r)



DR



Double side type · Doppelseitige Ausführung

Positive chip breaker with strong cutting edge for light to medium rough machining of steel and cast iron.

Positiver Spanbrecher mit stabiler Schneidkantenausführung für die leichte bis mittlere Schruppbearbeitung von Stahl und Gusswerkstoffen.

DR



Single side type · Einseitige Ausführung

Positive chip breaker with strong cutting edge for light to medium rough machining of steel and cast iron.

Positiver Spanbrecher mit stabiler Schneidkantenausführung für die leichte bis mittlere Schruppbearbeitung von Stahl und Gusswerkstoffen.

M P

double side ap· d.o.c.=2.5~8(mm)
f=0.2~0.6(mm/r)

single side ap· d.o.c. =2.5~20(mm)
f = 0.2~1.2(mm/r)



NEW

ER



NEU

Double side type · Doppelseitige Ausführung

New developed chip breaker with positive geometry for low cutting force. Suitable for roughing operation of stainless steel and steel.

Neu entwickelter positiver Spanbrecher für niedrige Schnittkräfte. Besonders geeignet für die Schruppbearbeitung von rostfreiem Stahl und Stahl.

ER



Single side type · Einseitige Ausführung

New developed chip breaker with positive geometry for low cutting force. Suitable for roughing operation of stainless steel and steel.

Neu entwickelter positiver Spanbrecher für niedrige Schnittkräfte. Besonders geeignet für die Schruppbearbeitung von rostfreiem Stahl und Stahl.

Schruppen · Roughing

Chip breaker Overview · Spanbrecher Übersicht

Schruppen · Roughing



P M
 ap· d.o.c.= 5~15(mm)
 f= 0.5~1.2(mm/r)



Chip breaker with strong cutting edge and resistant to plastic deformation for single side inserts. Suitable for rough machining with high metal cutting rate for steel and stainless steel application.

Spanbrecher mit stabiler Schneidkantenausführung mit hoher Deformationsbeständigkeit für einseitige Wendeschneidplatten. Anwendung für die Schruppbearbeitung von Stahl und rostfreiem Stahl.

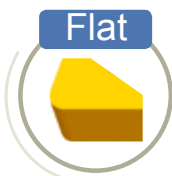

K
 ap· d.o.c.= 0.3~12(mm)
 f= 0.1~0.6(mm/r)



Flat insert without chip breaker. Stable insert with high edge strength for roughing operation in cast iron materials.

Glatte Platte ohne Spanbrecher. Mit einer stabilen Schneidkante für die Schruppbearbeitung von Gusswerkstoffen.

CBN & PCD

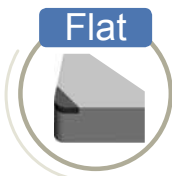

PCBN H PKD N
 ap· d.o.c.=0.05~0.5(mm)
 f=0.05~0.3(mm/r)



Special grades: for machining of hardened materials and cast iron (CBN).
 for machining of non-ferrous metals (e.g. Aluminium) and non-metal materials (PCD)
 Spezielle Sorten: Für die Bearbeitung von gehärteten Stählen, Gusswerkstoffen (CBN). Für die Bearbeitung von NE-Metallen (z.B. Aluminium) und nicht-metallischen Werkstoffen (PCD)

Ceramic Insert

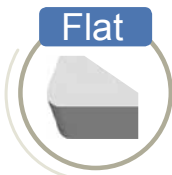

K H P
 ap· d.o.c.= 0.1~3(mm)
 f= 0.05~0.4(mm/r)



Ceramic inserts for machining of hardened steel, cast iron and steel.
 Keramikwendeschneidplatten für die Bearbeitung von gehärtetem Stahl, Gusswerkstoffen und Stahl.

General Turning · Allgemeine Drehbearbeitung

General Turning Inserts · Allgemeine WSP Übersicht

Chip breaker Overview · Spanbrecher Übersicht

Positive Inserts
Positive Wendeschneidplatten

P M

ap· d.o.c. = 0.05~2.5(mm)
f= 0.03~0.25(mm/r)



Special grinded chip breaker groove for precision machining and high surface quality. This G-class inserts with a sharp cutting edge and small corner radius for fine finishing operation without vibration.

Exakt geschliffene einseitige Spanleitstufe für die Hochpräzisionsbearbeitung mit hoher Oberflächengüte. Diese G-Toleranz Platten besitzen scharfe Schneiden und kleine Eckenradien. Für die Feinstbearbeitung ohne Vibrationen.

R/L



P M K

ap· d.o.c. = 0.05~1(mm)
f= 0.05 ~0.3(mm/r)



Special chip breaker in combination with cermets grades. Sharp cutting edge with excellent chip control. For high surface finishing and precision machining.

Spezieller Spanbrecher in Kombination mit Cermetsorten. Mit scharfer Schneide für die Präzisionsbearbeitung mit hervorragendem Spanbruch und sehr guter Oberflächengüte.

SF



P M K

ap· d.o.c. = 0.1~2(mm)
f= 0.05~0.3 (mm/r)



Chip breaker for finishing and semi-finishing of steel and cast iron. Especially for internal machining.

Spanbrecher für die Schlicht- bis mittlere Bearbeitung von Stahl und Gusswerkstoffen. Besonders geeignet auch für die Innenbearbeitung.

HF



M S

ap· d.o.c. = 0.1~2(mm)
f= 0.05~0.3 (mm/r)



Sharp, positive cutting edge for finishing and semi-finishing of austenitic stainless steel, soft steel and low carbon steel. Suitable for continuous to light interrupted cut.

Sehr scharfe und positive Schneidkante für die Schlicht- bis mittlere Bearbeitung von austenitischem, rostfreiem Stahl, weichem Baustahl und Stahl mit niedrigem Kohlenstoffgehalt.

EF



NEU

NEW

Feinstbearbeitung · Finishing

Schlichten · Finishing

Chip breaker Overview · Spanbrecher Übersicht

Schlichten · Finishing

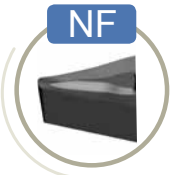

S M
 ap· d.o.c.= 0.05~1(mm)
 f=0.05~0.2 (mm/r)



Chip breaker with sharp and positive cutting edge. NF combined with Grade YBG102 is best solution for finishing of heat resistance super alloys (Ni-based, Fe-based and Co based material).

Geschliffene Wendeschneidplatte mit einer scharfen, positiven Schneidkante. In Kombination mit der Sorte YBG102 ist dieser Spanbrecher besonders für die Schlichtbearbeitung von wärmfesten Materialien geeignet (z.B. Ni- basiert, Fe-basiert und Co-basiert).

Mittlere Bearbeitung · Semi-Finishing



P M K
 ap·d.o.c. =1~4(mm)
 f=0.2~0.5(mm/r)



Chip breaker for medium machining of steel or cast iron. Suitable for internal and external turning.

Spanbrecher für die mittlere Bearbeitung von Stahl und Gusswerkstoffen. Einsetzbar bei der Innen- und Außenbearbeitung.

NEU

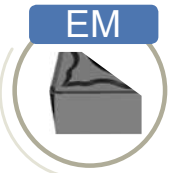

M S
 ap· d.o.c. = 1~4(mm)
 f= 0.2~0.5(mm/r)



NEW

Upgrade sharp and strong cutting edge for semifinishing of adhesive steel and austentic stainless steel.

Scharfe und stabile Schneidkante für die mittlere Bearbeitung von rostfreien adhäsiven Stählen und austenitischen Werkstoffen.

Chip breaker Overview · Spanbrecher Übersicht

Positive Insert
Positive Wendeschneidplatten

Mittlere Bearbeitung · Semi-Finishing

P K

ap· d.o.c.= 1~8(mm)
f= 0.2~0.6(mm/r)



Chip breaker for round inserts. Suitable for semi precision machining and profile modelling machining of steel and cast iron.

Umlaufende Spanleitstufe für runde WSP. Für die mittlere Bearbeitung und Profildrehen von Stahl- und Gusswerkstoffen.

Schruppen · Roughing

K

ap· d.o.c.= 0.05~1(mm)
f=0.05~0.2 (mm/r)

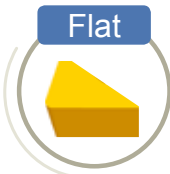

Flat insert without chip breaker. Stable insert with high edge strength for roughing operation in cast iron materials.

Glatte Platte ohne Spanbrecher. Mit einer stabilen Schneidkante für die Schruppbearbeitung von Gusswerkstoffen.

Schruppen · Roughing

P M K

ap· d.o.c. =2~5(mm)
f=0.2~0.4(mm/r)



Chip breaker with strong cutting edge for light to medium rough machining of steel stainless steel and cast iron. Suitable for internal and external machining.

Spanbrecher mit stabiler Schneidkantenausführung für die leichte bis mittlere Schruppbearbeitung von Stahl und Gusswerkstoffen. Einsetzbar bei der Innen- und Außenbearbeitung.

P

ap· d.o.c. =3~10(mm)
f=0.3~1.2(mm/r)



Recommended chip breaker for rough machining steel materials. Single chip breaker with strong cutting edge. First choice for profile modelling machining.

Spezieller Spanbrecher mit einer verstärkten Schneidkantenausführung für die Schruppbearbeitung. Besonders geeignet für die Konturbearbeitung bei höherer Produktionssicherheit von Stahlwerkstoffen unter ungünstigen Bedingungen.

Chip breaker Overview · Spanbrecher Übersicht

Aluminium Bearbeitung · Machining

N

ap· d.o.c.=0.1~5(mm)
f=0.05~0.4(mm/r)



Special chip breaker for aluminum alloy and non ferrous metal machining G tolerance insert with large rake angle, surface polishing treatment, effectively preventing build up edge and getting high quality machining surface and long tool life.



Speziell geschliffener Spanbrecher für die Bearbeitung von Aluminium, Aluminiumlegierungen (NE-Metallen). G-Toleranz WSP mit großem Spanwinkel und polierter Oberfläche zur Vermeidung von Aufbauschneiden. Hervorragender Spanabfluss, gute Oberflächengüten und lange Standzeiten.

CBN & PKD

PCBN

H

PKD

N

ap· d.o.c.=0.05~0.5(mm)
f=0.05~0.3(mm/r)



Special inserts G tolerance with brazed CBN or PCD Tip. CBN suitable for finishing of hardened component and cast iron. PCD suitable for finishing of non ferrous metal and non-metal materials.

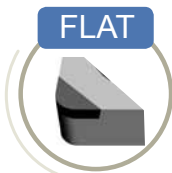

Spezielle G Toleranz WSP mit gelöteter CBN oder PKD Schneidecke. CBN ist besonders für die Schlichtbearbeitung von gehärtetem Stahl oder Grauguss geeignet, PKD für die Schlichtbearbeitung von NE-Metallen und nicht metallischen Werkstoffen (Glasfiber, Keramik, glasfaserverstärkte Kunststoffe).

General Turning · Allgemeine Drehbearbeitung

Turning · Drehen

General Turning Inserts · Allgemeine WSP Übersicht

Chip breaker Cutting Condition · Spanbrecher Schnittdatenempfehlung

Main Chip breaker for general Turning · Hauptspanbrecher für allgemeine Drehbearbeitung

Negative Insert · Negative Wendeschneidplatten

ap · d.o.c.(mm)

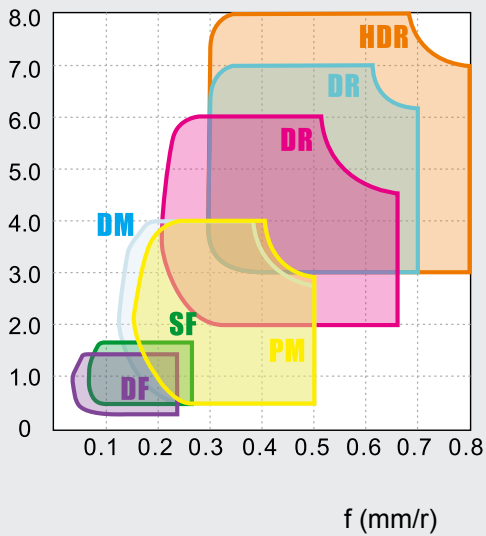

Material: Steel · Stahl C 45

ap · d.o.c.(mm)

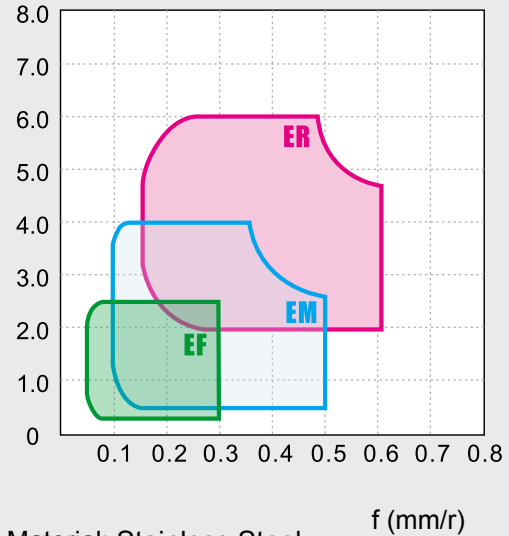

Material: Stainless Steel · Rostfreier Stahl (1Cr18Ni9Ti)

Positive Inserts · Positive Wendeschneidplatten

ap · d.o.c.(mm)

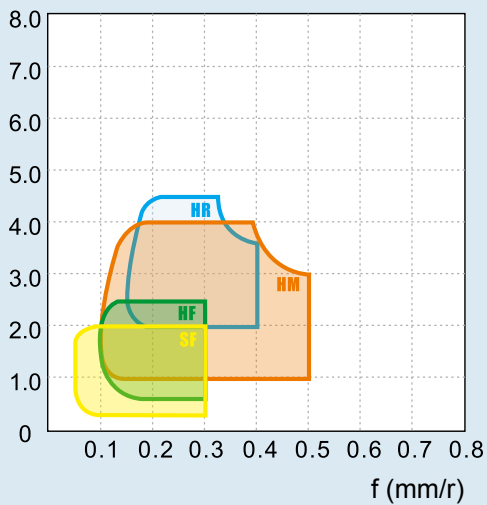

Material: Steel · Stahl C 45

ap · d.o.c.(mm)

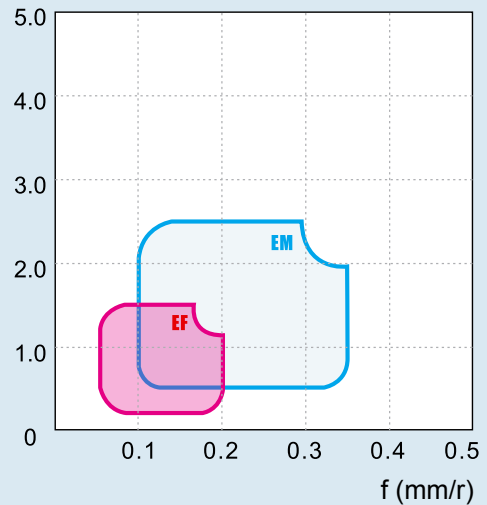

Material: Stainless Steel · Rostfreier Stahl (1Cr18Ni9Ti)

Chip breaker application field · Spanbrecher Anwendungsfeld

Example · Beispiel:

Insert · WSP: CNMG120408-DF

Cutter · Halter: PCLNL2525M12

Material: C 45 steel

V_C : 200(m/min)

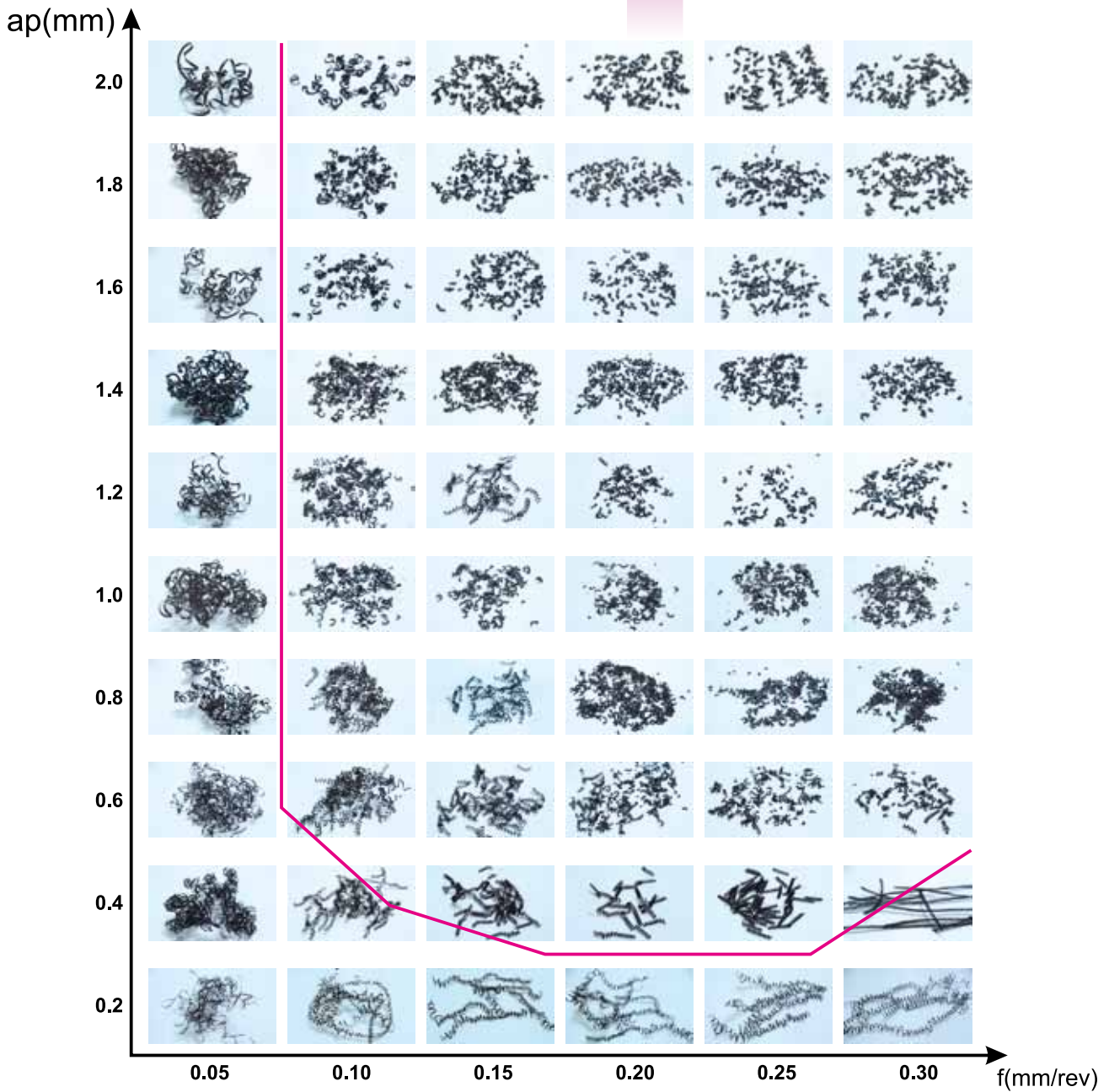
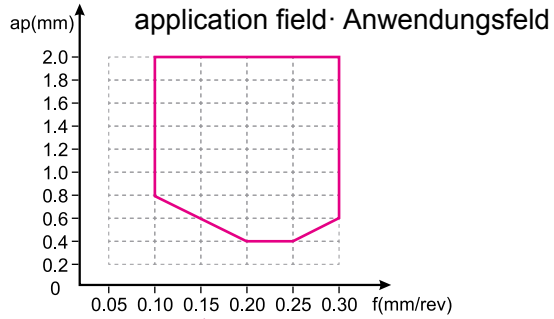

WVG



chip breaker series
WG Spanbrecher Serie

Turning Insert with **WIPER**-Technology
Drehplatten mit **WIPER**-Technologie

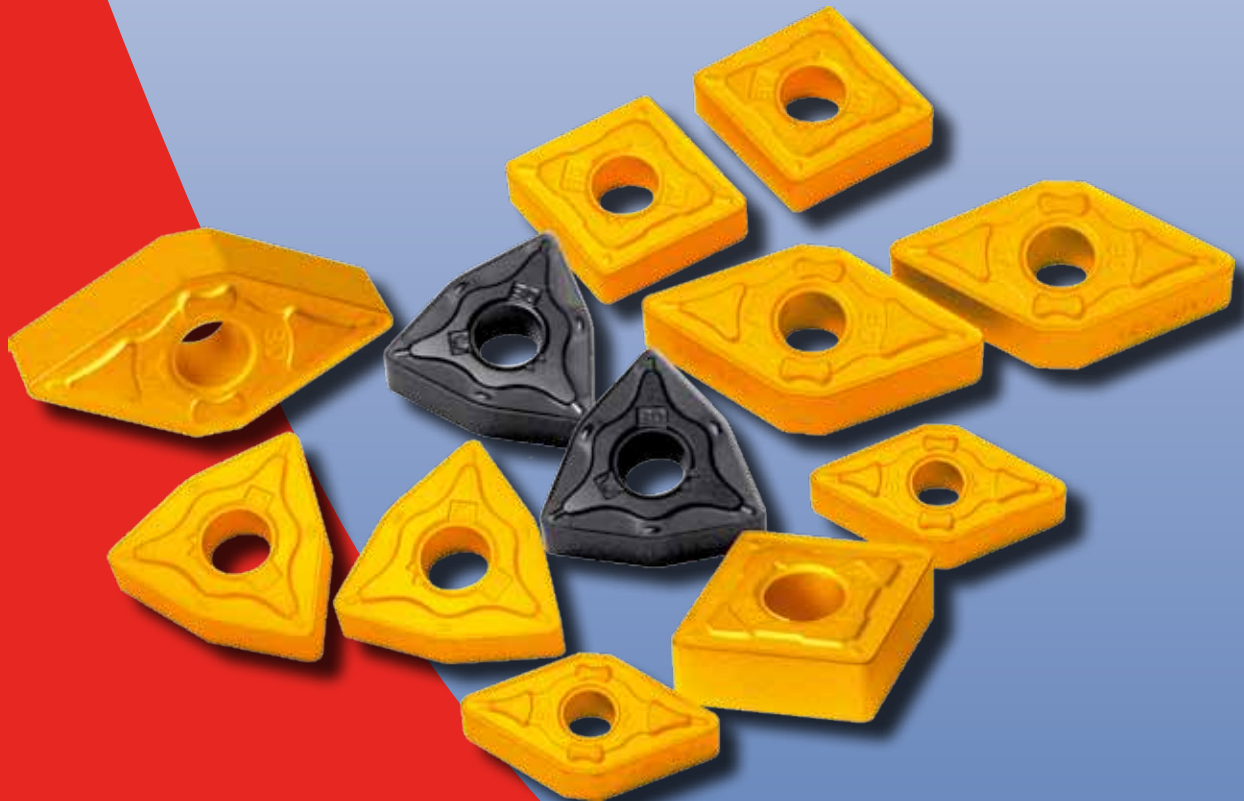

WIPER



Machining a good surface finish on turned components has become a demand for semi-finishing and finishing operations. The Wiper technology has provided turning with a new means to achieve improved production performance where the key is to being able to raise the feed rate.

Bei der Schlicht- bis mittleren Bearbeitung von Drehteilen nimmt die Realisierung von hohen Oberflächengüten an Bedeutung zu. Dank der Wiper-Technologie kann diese Anforderung auch bei höheren Vorschüben realisiert werden. Ein weiterer Vorteil ist die Steigerung der Produktivität.

A Wiper insert has a special design of nose configuration. It has been developed to provide a high capability of generating a better surface finish. On the other hand, is capable of machining the same finish at a much higher feed.

Eine Wiperplatte zeichnet sich durch eine spezielle Modifikation des Eckenradius aus. Dadurch ist bei gleichem Vorschub, verglichen mit einer herkömmlichen Drehplatte, eine deutliche Verbesserung der Oberflächengüte zu erzielen. Eine weitere Möglichkeit ist die Verdoppelung des Vorschubes für eine höhere Produktivität, wobei die Oberflächengüten gleich bleiben.

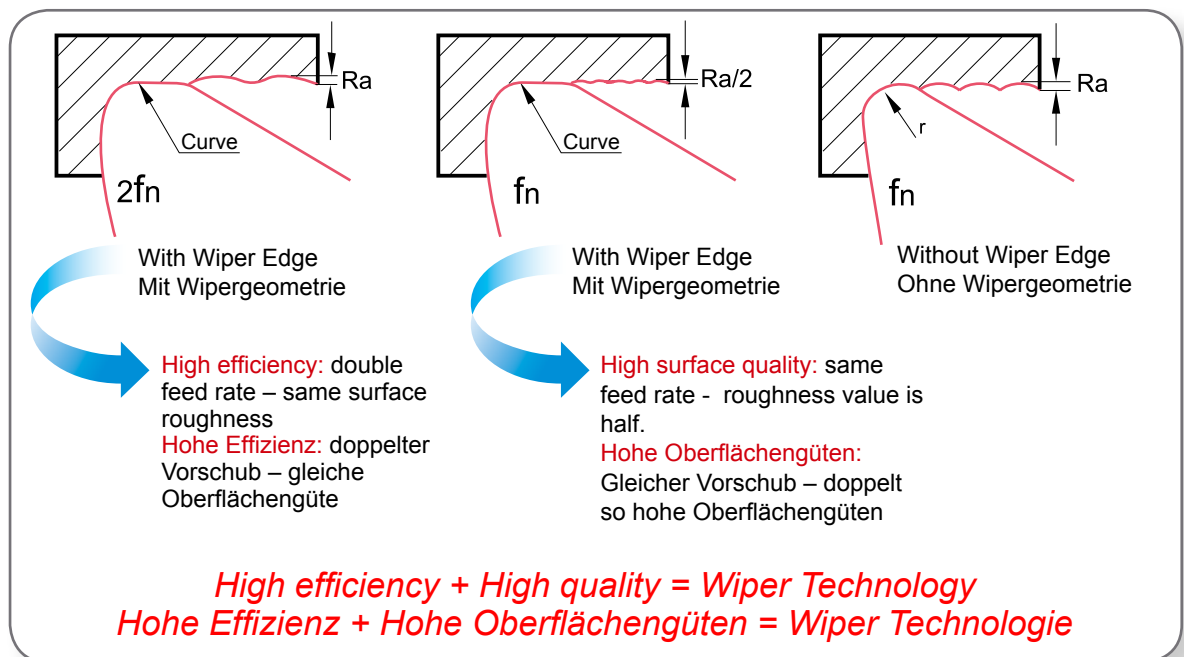

Feature-Merkmale:

By using a Wiper inserts you can get excellent surface quality and eliminate many grinding operations. You also get better component quality and roundness compared to grinding.

Durch die Verwendung von Wendeschneidplatten mit Wipertechnologie lassen sich hohe Oberflächengüten erzielen und somit viele Schleifoperationen ersetzen. Die Werkstückqualitäten z.B. in Bezug auf Rundheit kann im Vergleich zum Schleifen ebenfalls gesteigert werden.



EF EM ER

Special chip breaker series for soft steel, stainless steel and heat resistance Superalloy
 Spezielle Spanbrechererrien besonders für die Zerspaltung von weichem Stahl, rostfreien (M) Stählen und warmfesten Superlegierungen.



-EF

Sharp positive cutting edge for finishing and semifinishing of austenitic stainless steel, soft steel and low carbon steel. Suitable for continuous to light interrupted cut.

Scharfer, positiver Spanbrecher für die Schlichtbearbeitung von rostfreien Stählen, weichem Stahl, Automatenstahl und für Stähle mit niedrigem Kohlenstoffgehalt. Für glatte bis leicht unterbrochene Schnitte.



-EM

Sharp cutting edge with stronger edge line for medium cut even in interrupted cut.

Scharfe, stabile Schneidkante für die mittlere Bearbeitung von Werkstoffen auch im unterbrochenen Schnitt.



-ER

Special edge design with excellent balance between edge strength and sharpness. Suitable for roughing operation.

Speziell entwickelter Spanbrecher mit exzellenter Kantenstabilität bei gleichzeitiger Schneidenschärfe, für die Schruppbearbeitung.

Example - Beispiel:

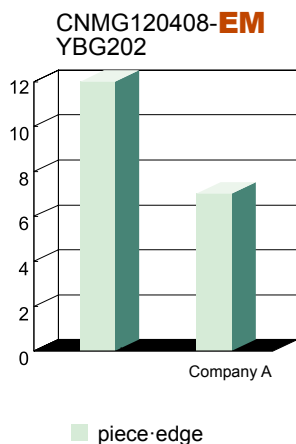

Parameter:	
D	135mm
V _c	150 m/min
f	0.25mm/rev
ap	2.5 mm

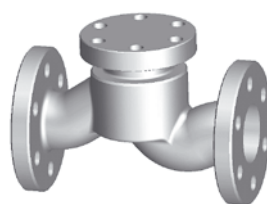

Valve - Ventil

Example - Beispiel:

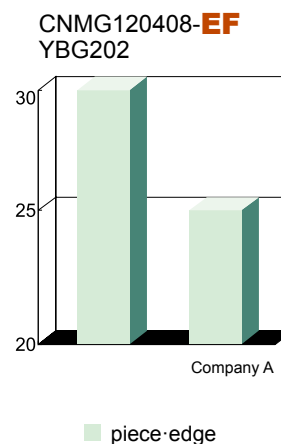

Parameter:	
D	89 mm
V _c	180 m/min
f	0.15mm/rev
ap	1.0 mm

NF NM



Special chip breaker series for machining heat resistance and super alloy material.
Neue Spanbrecherserie für die Bearbeitung von hochlegierten, warmfesten Materialien.

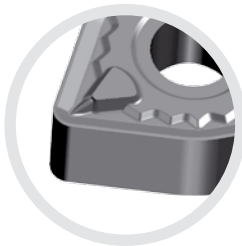
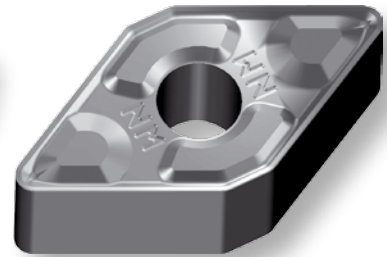
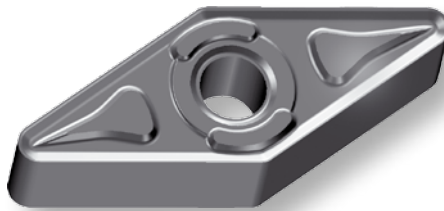
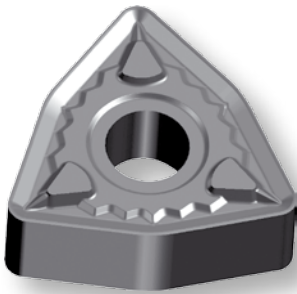

-NF

Ground inserts with sharp and positive cutting edge. NF combined with grade YBG102 is a good solution for the finishing of heat resistant super alloys (nickel-based such as Inconel 700,718, iron-based and cobalt-based alloys). $a_p=0.2\sim 1.0\text{mm}$, $V_c=40\sim 100\text{m/min}$.

Geschliffene Wendeschneidplatte mit einer scharfen positiven Schneidkante. NF in Kombination mit der Sorte YBG102 ist eine gute Lösung für Schlichtbearbeitungen von warmfesten Superlegierungen (Ni-basiert wie Inconel 700,718, Fe-basiert und Co-basiert) $a_p=0.2\sim 1.0\text{mm}$, $V_c=40\sim 100\text{m/min}$.

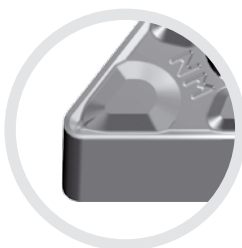

-NM

Sharp cutting edge with positive multi-rakes. Special for the semifinishing of heat resistant super alloys.

Scharfe Schneidkante mit positivem Multi-Spanwinkel. Besonders geeignet für die Bearbeitung von warmfesten Superlegierungen.



SF

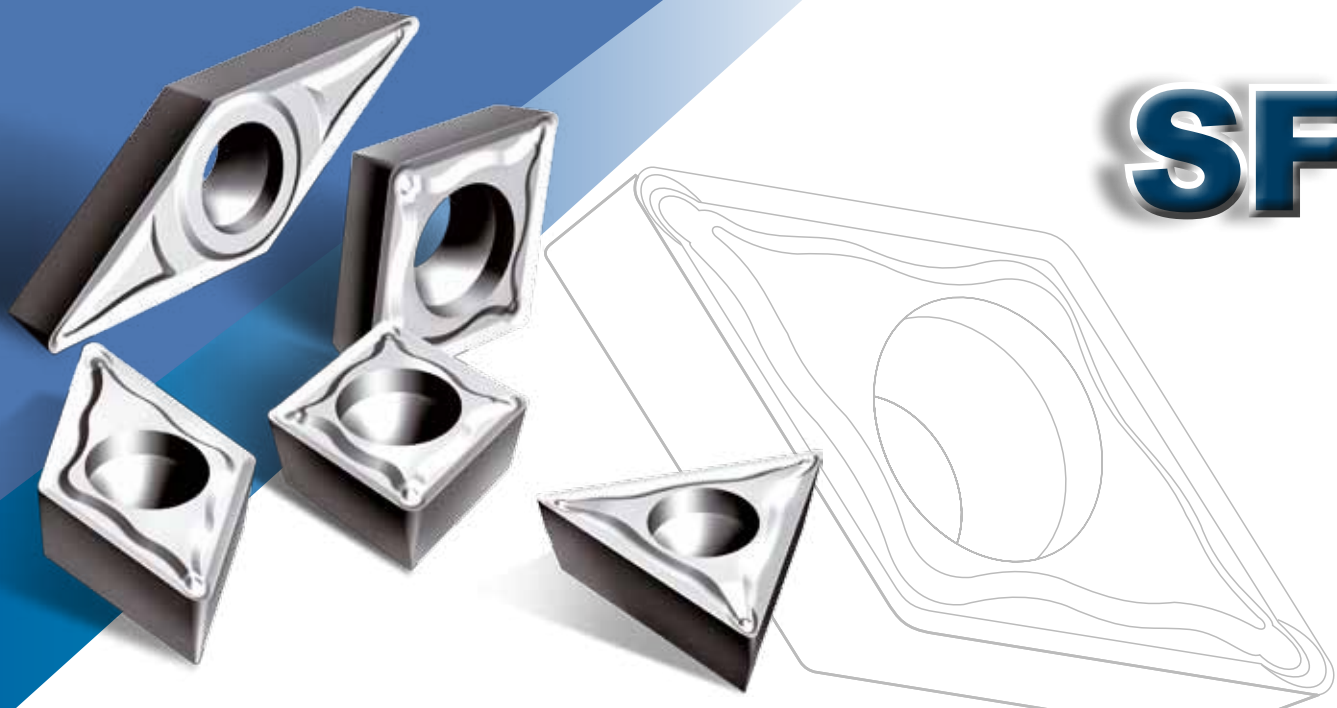

Chip breaker for high precision machining
Spanbrecher für die Hochpräzisionsbearbeitung

New chip breaker geometry for fine-finishing machining of steel, stainless steel and cast iron. In combination with our cermet grades a good solution for high precision production.

Neue Spanbrecher für die Feinstbearbeitung von Stahl, rostfreiem Stahl und Gusswerkstoffen. In Kombination mit unseren Cermetsorten die beste Wahl für die Hochpräzisionsbearbeitung.

1. High precision
Hohe Genauigkeit
2. Sharp cutting edge to reduce cutting force and vibration
Scharfe Schneidkante zur Reduktion von Schnittkraft und Vibrationen.
3. Excellent chip control
Ausgezeichnete Spankontrolle
4. Excellent surface quality
Ausgezeichnete Oberflächengüte

Best result in combination with our carbide anti-vibration boring bars.
Beste Ergebnisse in Kombination mit unseren Antivibrations Hartmetallbohrstangen.



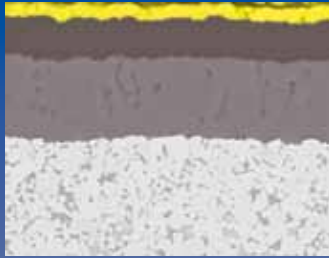

YBC251 coating

**Application field CVD,
turning grade of steel**
**Anwendungsbereich
CVD, Drehsorten für Stahl**

YBC 151

CVD coated grade with good wear resistance in combination with MT-Ti(CN), thick layer AL₂O₃, TiN coating. Good for finishing of steel and dry machining.

CVD-beschichtete Premiumsorte mit ausgezeichneter Verschleißfestigkeit. Die Kombination von MT-TiCN und einer dicken AL₂O₃ TiN Auflage eignet sich zum Schlichten von Stahl und zur Trockenbearbeitung.

YBC 251

CVD premium universal grade with excellent combination of toughness and wear resistance. In combination with MT-Ti(CN), thick layer AL₂O₃, TiN coating this grade is first choice for medium to light interrupted cutting of steel.

CVD-beschichtete Hochleistungs-Allroundsorte mit guter Schneidkantensicherheit und Verschleißfestigkeit. In Verbindung mit der MT-TiCN und einer dicken AL₂O₃ TiN Beschichtung eignet sich diese Sorte für die mittlere Bearbeitung bis zu leichtem Schruppen von Stahl.

YBC 351

CVD coated premium grade with high toughness and wear resistance. In combination with MT-Ti(CN), thick layer AL₂O₃, TiN coating this grade is suitable for rough machining of steel under unstable condition.

CVD-beschichtete Premiumsorte mit hoher Zähigkeit und Verschleißfestigkeit. Die Kombination von MT-TiCN und einer dicken AL₂O₃ TiN Auflage eignet sich besonders für die leichte bis schwere Schruppbearbeitung von Stahl.

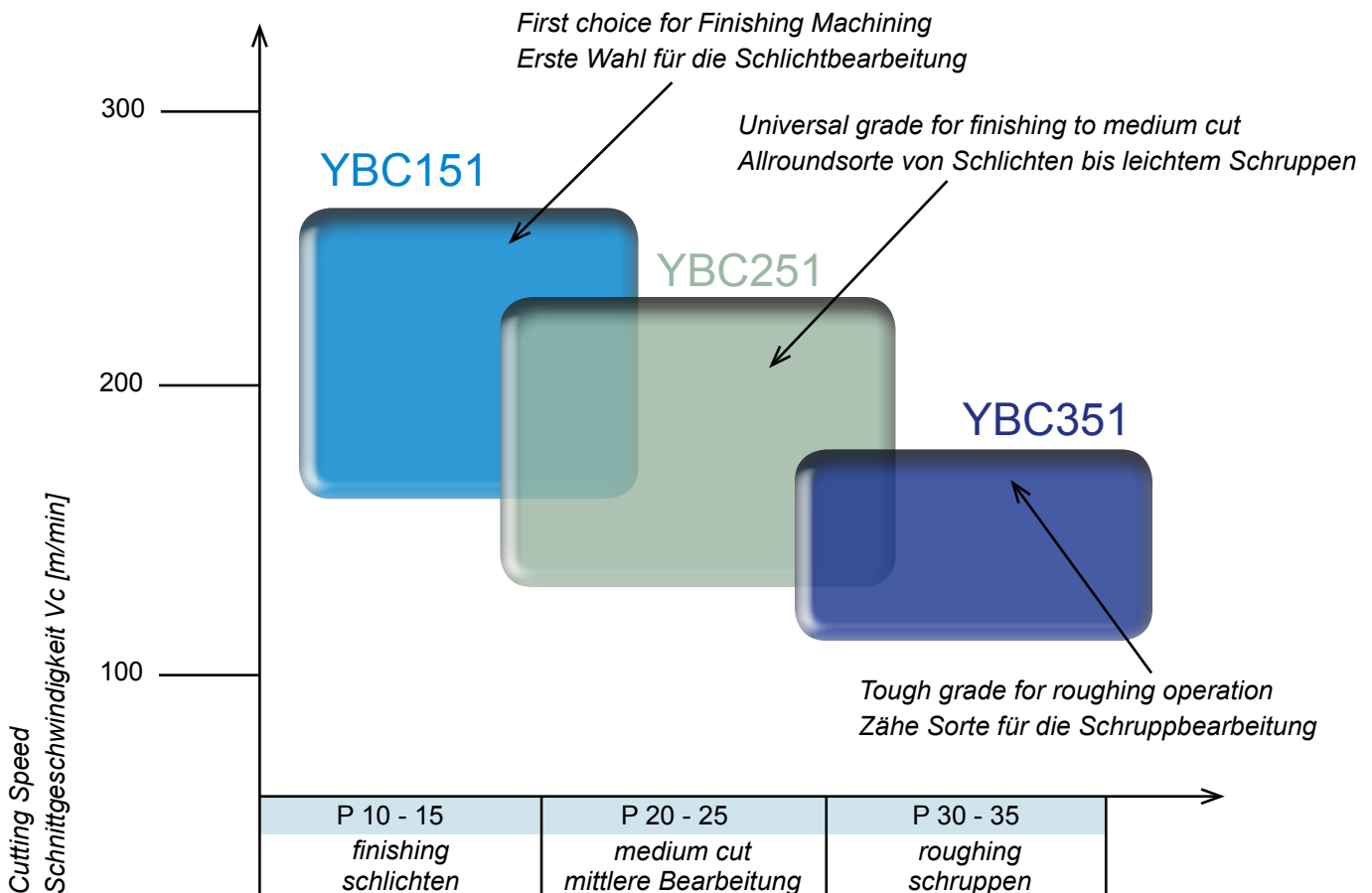

Application field CVD,
turning grade
of stainless Steel

Anwendungsbereich CVD,
Dreharten für
rostfreien Stahl

YBM 151

Substrate with special structure, in combination with TiCN, thin layer AL₂O₃, TiN coating. With resistance against diffusion wear and plastic deformation it is good for finishing and semi-finishing of stainless steel.

CVD-beschichtetes Hartmetall. Die besonders strukturierte Kombination mit TiCN und Al₂O₃, TiN Auflage hat eine ausgezeichnete Schichthaftung und Widerstandsfähigkeit gegen plastische Verformung. Gut geeignet für die Schlicht- bis mittlere Bearbeitung von rostfreiem Stahl.

YBM 251

Substrate with good toughness and strength, in combination with Ti(CN), thin layer AL₂O₃, TiN coating. It is a premium grade for semi-finishing to light roughing of stainless steel at continuous and intermittent machining conditions.

Universal einsetzbares CVD-beschichtetes Hartmetall aus TiCN, Al₂O₃ und TiN mit guter Zähigkeit und Verschleißfestigkeit. Optimiert für mittlere Drehbearbeitung von rostfreiem Stahl mit und ohne Schnittunterbrechung.

YBM 351

Coated carbide grade with very good strength and impact resistance. It is suitable for rough turning of stainless steel at low to moderate cutting speed or interrupted cutting,

Beschichtete Hartmetallsorte mit ausgezeichneter Widerstandsfähigkeit und Schneidkanten-sicherheit. Ideal für schwere Schruppbearbeitung von rostfreiem Stahl und Stahl bei mittleren Schnittgeschwindigkeiten oder bei Schnittunterbrechung.

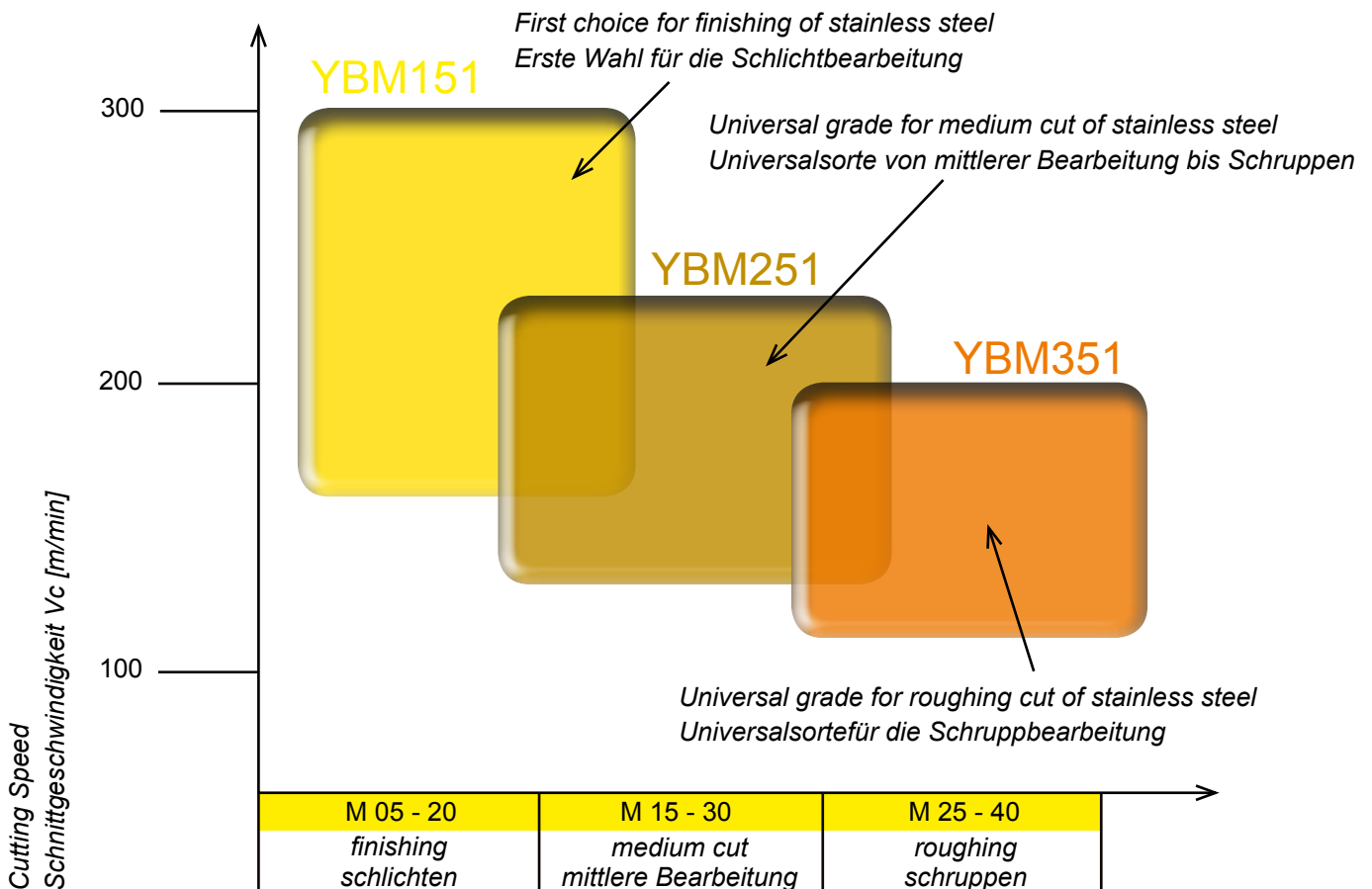

YBD

Application field CVD,
turning grade of Cast Iron
Anwendungsbereich
CVD, Drehsorten für Guss

YBD 052

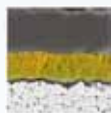

CVD coated grade with excellent wear resistance in combination with MT-Ti(CN), thick layer AL₂O₃. Best grade for machining of gray cast iron (GG) under high speed and dry machining.

CVD-beschichtete Premiumsorte mit ausgezeichneter Verschleißfestigkeit. Die Kombination von MT-TiCN und einer dicken AL₂O₃ Auflage eignet sich besonders zum Bearbeiten von Grauguss (GG) bei hohen Schnittgeschwindigkeiten und Trockenbearbeitung.

YBD 102

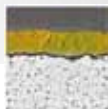

Modified CVD coating the hard fine grain carbide substrate. It is optimized for machining of cast iron, special nodular cast iron and hard steel at high speeds.

Modifizierte CVD Beschichtung auf einem hartem feinkörnigen Hartmetall. Es optimiert für die Bearbeitung von Guss, besonders Kugelgraphitguss und hoch vergütetem Stahl bei hohen Geschwindigkeiten.

YBD 152

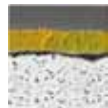

Hard medium fine corn substrate in combination of TiCN, thick AL₂O₃ coating. It is suitable for machining of gray cast iron and nodular cast iron under normal cutting conditions from low to moderate cutting speeds.

Hartes mittel-feinkörniges Substrat mit TiCN, dicker AL₂O₃ Auflagen. Es ist geeignet für die Bearbeitung von Grauguss und Kugelgraphitguss mit niedrigen bis mittleren Schnittgeschwindigkeiten.

YBD 252



Tough substrate in combination with TiN, TiCN, thick AL₂O₃ coating. It is good for turning of cast irons under favorable conditions. And for milling of cast iron and alloy steel.

Zähes Substrat mit TiN, TiCN, dicke AL₂O₃ Auflagen. Zum Drehen von Guss bei ungünstigen Bedingungen. Zum Fräsen von Guss und legierten Stahl.

Special High Speed Finishing grade for grey cast iron material
Speziell für die Highspeed-Schlichtbearbeitung von Grauguss

Optimized grade special for nodular cast iron.
Optimierte Qualität, besonders für Kugelgraphitguss.

Universal grade with thick Al₂O₃ coating
Allroundsorte mit dicker Al₂O₃ Beschichtung

Tough grade for unstable condition
Zähe Sorte bei ungünstigen Bedingungen

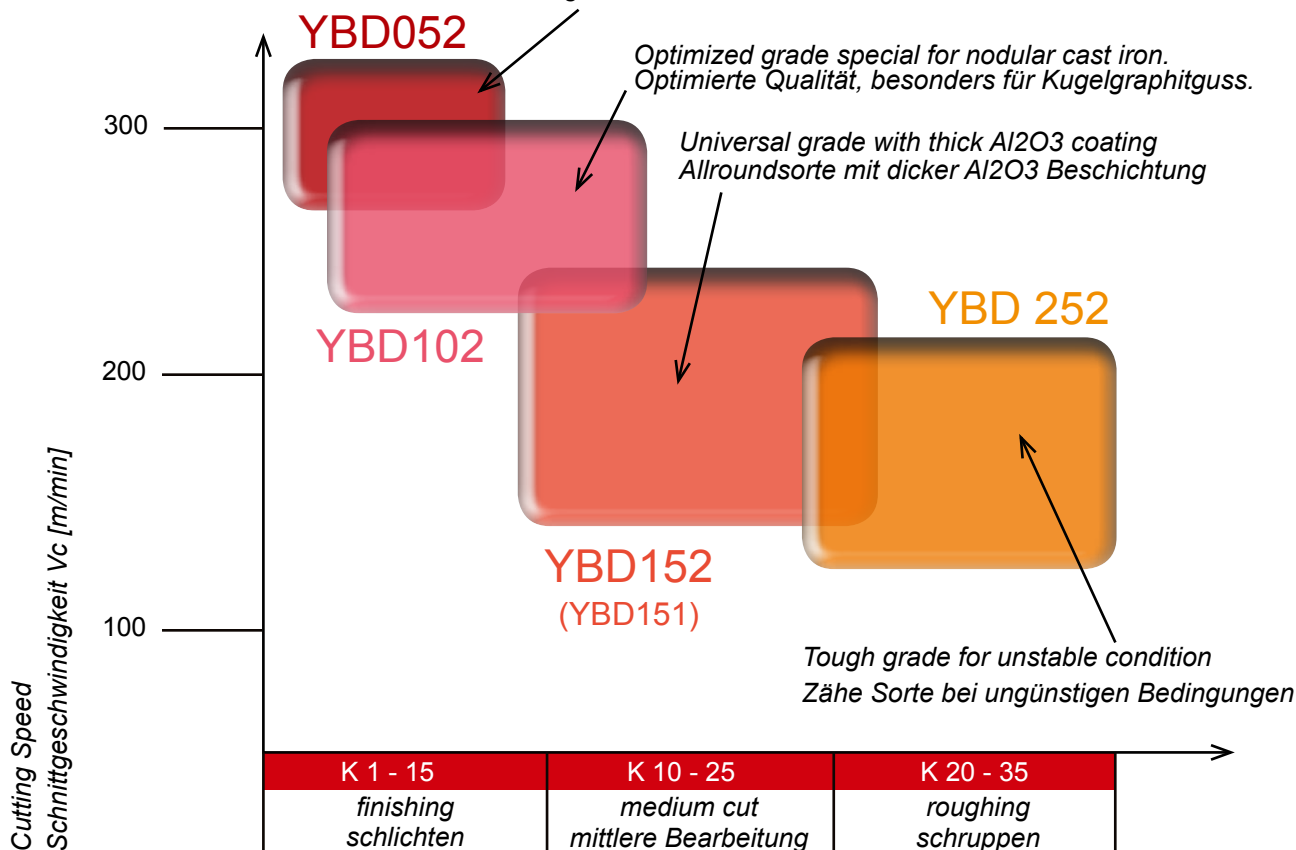

Turning · Drehen



- Recommended combination of grades, chip breaker and cutting data.
Empfohlene Kombination von Sorten, Spanbrechern und Schnittdaten.

P		M		K	
grade Sorte	chip breaker Spanbrecher	grade Sorte	chip breaker Spanbrecher	grade Sorte	chip breaker Spanbrecher
YBC151 YBC152	DF	YBM151	EF EM ER	YBD052	PM
YBC251 YBC252	DM PM	YBM251	EM ER	YBD102	PM, DR
YBC251 YBC252	DR (doppelseitig)	YBM351	EM ER	YBD152	Flat, DR
YBC351	DR			YBD252	Flat
YBC351	HDR				

- Recommended cutting condition · Empfohlene Schnittdaten

Workpiece Material Werkstück Material	application · Anwendung	grade · Sorte	Recommended Cutting Speed m/min Schnittgeschwindigkeit m/min
P Steel Stahl	Finishing Schlichten	YBC151	180-460
		YBC152	220-500
	Semi-finishing Mittlere Bearbeitung	YBC251	160-440
		YBC252	180-480
	Roughing	YBC351	130-380
M Stainless Steel Rostfreier Stahl	Semi-finishing Mittlere Bearbeitung	YBM151	110-280
		YBM251	
		YBM 351	
K Cast Iron Gusseisen	Roughing Schruppen	YBD052	200-500
		YBD102	200-480
	Semi-finishing Mittlere Bearbeitung	YBD151	180-450
		YBD152	190-450
	Roughing	YBD252	150-380

Machining example · Bearbeitungsbeispiele

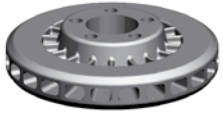
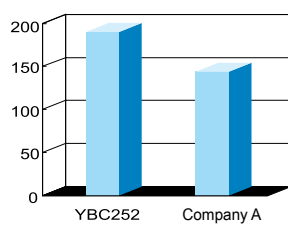
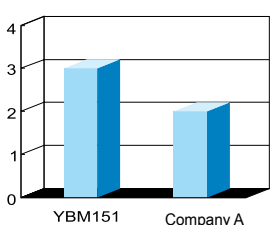
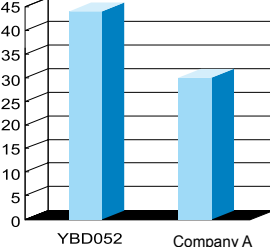
Application Anwendung	Typ	WNMG060408 PM	CNMG190616-ER	TNMA220412
	Grade Sorte	YBC252	YBM151	YBD052
Workpiece Werkstück				
Workpiece Material & Hardness		45 steel HB220	Duplex Stainless Steel HB260	Grey cast iron HB280
Cutting Condition Schnitt- bedingungen	Parameters Schnittdaten	V=220m/min ap=1.5~2mm f=0.25mm/r	V=103m/min ap=1.5mm f=0.3mm/r	V _{max} =400m/min ap=1.3~2.5mm f=0.4~1.1mm/r
	Cutting Liquid Kühlmittel	Dry Cutting · Trockenbearbeitung	Dry Cutting · Trockenbearbeitung	Dry Cutting · Trockenbearbeitung
Machining result Ergebnis	Werkstücke pro Schneide Workpiece Per Edge			

COATED Cemented Carbide PVD
Beschichtetes Hartmetall PVD

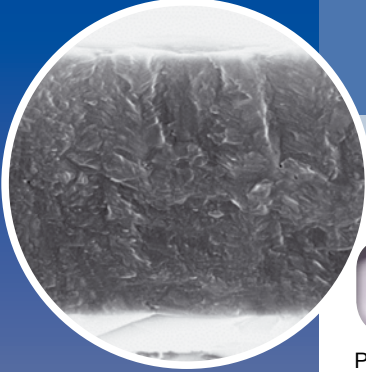

Makes it easy to machine materials which hard to be machined...

Die Lösung für die Bearbeitung von schwer zu zerspanenden Materialien...

YBG 102
N10 (N01-N10)
S10 (S01-S20)

PVD nano-TiAlN coated fine grain carbide grade. It is suitable for finishing and semi-finishing turning of high-temperature alloys, nonferrous metal (Aluminium with Si >= 12%) and finishing of stainless steel.

Nano-TiAlN PVD-beschichtete, fein körnige Hartmetallsorte. Gut geeignet zum Drehen von warmfesten Superlegierungen, NE-Metallen (Aluminium mit Si >= 12%) und zum Schlichten von rostfreiem Stahl.

YBG 202
P20 (P10-P25)
M20 (M10-M25)

PVD nano-TiAlN (2~4um) coated fine grain carbide grade. Good performance in combination of toughness and wear resistance, suitable for turning, parting, grooving of steel, stainless steel, cast iron and high-temperature alloys in finishing and semi-finishing machining.

Nano-TiAlN (2~4um) PVD beschichtete, feinkörnige Hartmetallsorte. Hervorragende Kombination von Zähigkeit und Verschleißfestigkeit. Zum Drehen, Ab- und Einstechen von Stahl, rostfreiem Stahl, Guss und warmfesten Superlegierungen bei leichter und mittlerer Bearbeitung.

YBG 205
P20 (P10-P30)
M20 (M10-M30)

New nano structure coating process ensures higher toughness but also hardness. This coating grade results in smooth surface finish on the insert, which reduce friction and improved chip flows. Excellent thermal and chemical resistance. This grade is suitable to machine stainless steel and high temperature alloy.

Neue Nano-Beschichtungsstruktur mit gleichzeitiger Härte und Verschleißfestigkeit bzw. Zähigkeit. Eine ultra glatte Schichtoberfläche vermindert die Reibung und garantiert einen optimierten Spanabfluß. Die exzellente thermische und chemische Widerstandsfähigkeit zeigt diese Sorte besonders bei der Bearbeitung von rostfreien Stählen und warmfesten Legierungen.

YBG 302
P30 (P20-P35)
M10 (M20-M35)

Substrate with good toughness and strength. PVD nano-TiAlN coated. It is a universal PVD grade for steel, stainless steel in turning, parting off, and grooving operation.

Universal einsetzbares PVD-beschichtetes Hartmetall mit guter Zähigkeit und Verschleißfähigkeit. Zum Drehen, Ab- und Einstechen von Stahl und rostfreiem Stahl sowie Guss.

Special Coating process for smooth insert surface
Reduce friction - best chip evacuation
combination of wear resistance and toughness
best thermal and chemical stability

Spezieller Beschichtungsprozeß mit sehr glatter Oberflächenstruktur
Reduzierte Reibung - exzellenter Spanfluß
Kombination aus Verschleißfestigkeit und Zähigkeit.
Beste thermische und chemische Stabilität.

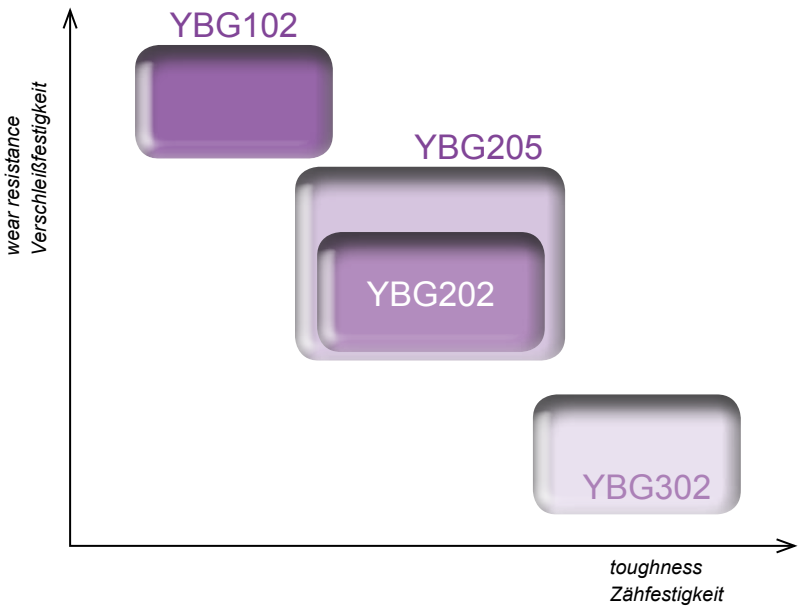

Turning · Drehen



- Recommended combination of grades, chip breaker and cutting data.
Empfohlene Kombination von Sorten, Spanbrechern und Schnittdaten.

P		M		S	
grade	chip breaker	grade	chip breaker	grade	chip breaker
Sorte	Spanbrecher	Sorte	Spanbrecher	Sorte	Spanbrecher
YBG202	DM	YBG202	EF	YBG102	NF
		YBG202	EM	YBG102	NM
		YBG205	EM		

- Recommended cutting condition · Empfohlene Schnittdaten

Workpiece Material Werkstück Material	application · Anwendung	grade · Sorte	Recommended Cutting Speed m/min Schnittgeschwindigkeit m/min
P Steel Stahl	Finishing Schlichten	YBG102	180-460
	Semi-finishing Mittlere Bearbeitung	YBG202	150-380
	Roughing Schruppen	YBG302	130-360
M Stainless Steel Rostfreier Stahl	Finishing · Semi-Finishing Schlichten · Mittlere Bearbeitung	YBG202	170-300
	Roughing Schruppen	YBG302	120-250
S Heat-Resistant Steel Warmfester Stahl	Finishing Schlichten	YBG102	30-90
	Roughing	YBG202	150-380

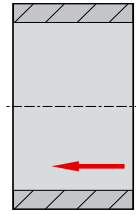
Machining example · Bearbeitungsbeispiele

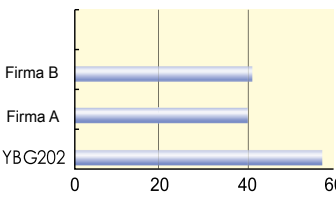
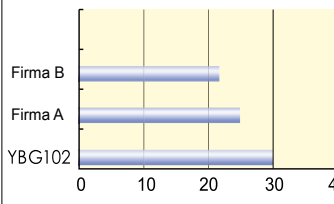
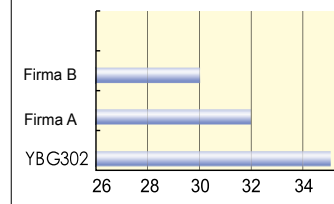
Application Anwendung	Typ Grade Sorte	CNMG120404-EF YBG 202	DNEG150404-NF YBG102	CMM160612-DR YBG302
Workpiece Werkstück				
Workpiece Material & Hardness		0Cr18Ni9 HB240	Inconel 718 HRC≥39	30Cr1Mo1V HB220-260
Cutting Condition Schnitt- bedingungen	Parameters Schnittdaten	V=200m/min ap=1mm f=0.15mm/r	Vc=80m/min ap=0.3mm f=0.15mm/r	V=100m/min ap=6mm f=0.5mm/r
	Cutting Liquid Kühlmittel	Dry Cutting · Trockenbearbeitung	Dry Cutting · Trockenbearbeitung	Dry Cutting · Trockenbearbeitung
Machining Effect Ergebnis				
Workpiece per Edge Werkstücke pro Schneide		0 20 40 60	0 10 20 30 40	26 28 30 32 34 36

Cermet Cermet

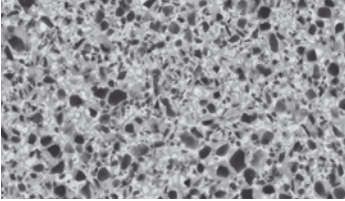

The cermet has higher hardness and oxygen-resistant under high temperature. The further advantage of cermets is to get the excellent surface quality and tolerance under higher speed.

Die Vorteile von Cermets zeigen sich in großer Härte, Oxidationsbeständigkeit und Hochtemperaturbeständigkeit. Die weiteren Vorteile von Cermets sind exzellente Oberflächen bei hohen Schnittgeschwindigkeiten und konstanter Maßhaltigkeit.

Coated-Cermet Beschichtetes Cermet

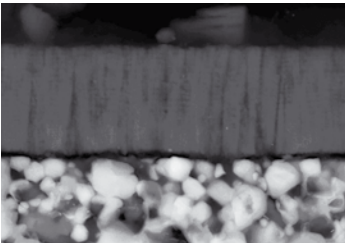

YNG151 TiCN based cermet, with the combination of hardness, excellent toughness, excellent, resistance thermoplastic. It is suitable for super-finishing and finishing of steel, stainless steel and cast iron.

YNG151C TiCN based cermet, through special pretreatment, plus PVD Nano-TiAlN coating. Optimal combination of high wear resistance and good edge toughness, suitable for the superfishing and finishing of steel, stainless steel and cast iron for high surface finishing.

YNG 151 auf der Basis von Ti(cn)Cermet verbunden mit Härte, Zähigkeit und Widerstandsfähigkeit gegen plastische Verformung und Aufbauschneidenbildung. Geeignet zum Schlichten und Feinschlichten von Stahl, rostfreiem Stahl und Guss für eine höhere Oberflächengüte.

YNG151C TiCN Cermet. Plus PVD NaNO-TiAlN Beschichtung: Optimale Kombination von sehr hoher Verschleißfestigkeit und Schneidkanten Zähigkeit. Zum Feinschlichten und Schlichten von Stahl, rostfreiem Stahl und Guss für eine hohe Oberflächengüte.

■ Recommended Cutting Conditions · Empfohlene Schnittdaten

Workpiece Material Werkstückstoff		application · Anwendung	Grade · Sorte	Recommended Cutting Speed m/min Schnittgeschwindigkeit m/min
	Steel/ Stahl	Finishing machining Schlichten	YNG151	260-550
			YNG151C	260-580
	Stainless Steel/ Rostfreier Stahl		YNG151	170-330
			YNG151C	160-350
	Cast Iron/ Gusseisen		YNG151	250-400
			YNG151C	270-420

Machining example · Bearbeitungsbeispiele



Application/ Anwendung: YNG151-CNMG120404-SF

Workpiece material and hardness: 20CrMnTi HB180-223
Werkstückhärte

Machining parameters v=220m/min

ap=0.5~1.0mm

f=0.14mm/r

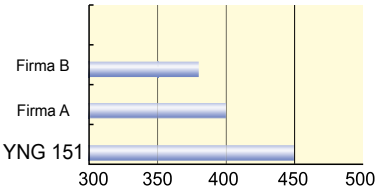

Brand	Speed Range (m/min)
Firma B	~350 - 400
Firma A	~350 - 450
YNG 151	~350 - 500

good chip control and surface · gute Spankontrolle und Oberfläche

UNCOATED CARBIDE grade is widely used for non-ferrous and heat resistant material.

UNBESCHICHTETES HARTMETALL wird überwiegend für die Bearbeitung von NE-Metallen und wärmefesten Legierungen eingesetzt.

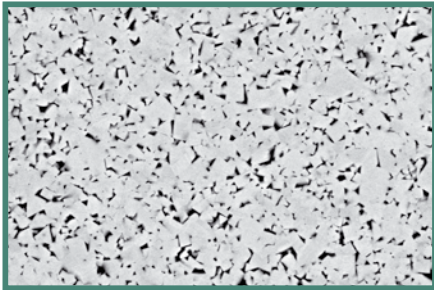

Substrate of YD101 - the combination of cemented carbide phase WC of fine grain and bonding phase Co.

YD101 ist ein unbeschichtetes Hartmetall mit feiner Körnung, einer Hardphase aus WC Carbide und eine Bindephase aus Cobald (Kombination).

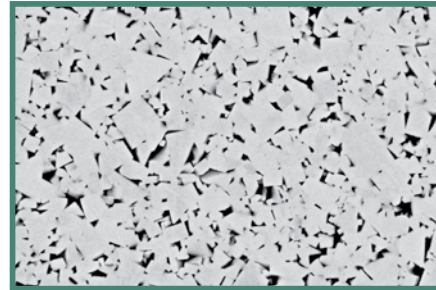

Substrate of YD 201 - the combination of cemented carbide phase WC of middle grain and bonding phase Co.

YD 201 ist ein unbeschichtetes Hartmetall mit mittlerer Korngröße, einer Hardphase aus WC Carbide und eine Bindephase aus Cobald.

■ Recommended Cutting Conditions · Empfohlene Schnittdaten

Workpiece Material Werkstückstoff		Application · Anwendung	Grade · Sorte	Recommended Cutting Speed m/min Schnittgeschwindigkeit m/min
P	Steel Stahl	Finishing Schlichten	YC10	130 - 360
		Roughing Schruppen	YC40	80 - 300
K	Cast Iron Gusseisen	Finishing Schlichten	YD051	100 - 170
		Semi-Finishing - Roughing Mittlere Bearbeitung -Schruppen	YD201	60 - 130
N	None-ferrite materials NE Metalle	Finishing · Semi-Finishing Schlichten · Mittlere Bearbeitung	YD101	110 - ...
S	Heat-Resistant Steel Wärmefester Stahl	Finishing Schlichten	YD101	20 - 50

Machining example · Bearbeitungsbeispiele

Example of Use

Bearbeitungsbeispiel

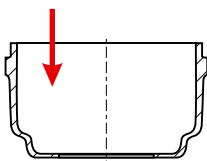

Insert: WSP: YD101-CCGX09T304-LH

Workpiece material and
hardness: Werkstückstoff
und Härte: ZL105 HB70

Machining parameters:

Schnittdaten:

$v=400\text{m/min}$

$a_p=1\text{mm}$

$f=0.3\text{mm/r}$

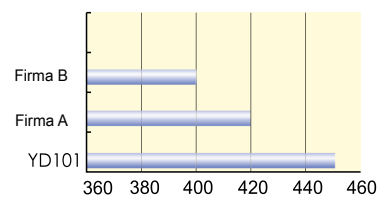

good chipcontrol and surface · gute Spankontrolle und Oberfläche

PCBN / PCD

Super-hard Cutting Material
Superharter Schneidstoff

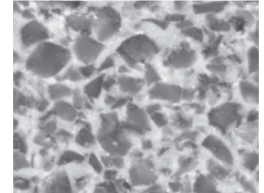
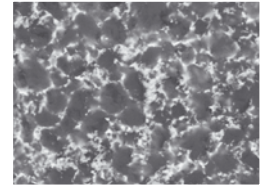

PCBN PCBN cubic boron nitride

PCBN with high hardness and good heat resistance for cutting of hardened steel (could be 1300°C), carbon steel, ball bearing steel, mould steel and high speed steel, grey cast iron, nodular graphite cast iron, chilled cast iron and Ni-based, Co-based, Cr-based and Fe-based high temperature alloy.

PCBN mit hoher Härte und Warmfestigkeit für die Bearbeitung bei hohen Temperaturen, z.B. 1300°C, bei der Bearbeitung von gehärtetem Stahl mit HRC von 50-60. Zur Bearbeitung von Stahl, Kugellagerstahl, Gussstahl, HSS, Grauguss, Kugelgraphitguss, Hartguss, Ni-, Fe-, Co-, Cr2- basis Superlegierungen.

Type · Typ	Grade Sorten	Application Anwendung	Characteristic Merkmale
Uncoated CBN Unbeschichtete CBN	YCB111	High speed continuous cutting Vollschnitt bei hoher schnittgeschwindigkeit	Best wear resistance grade and suitable for high speed continuous cutting Verschleißfeste Sorte besonders geeignet für die Hochgeschwindigkeitsbearbeitung im Vollschnitt
	YCB121	continuous and interrupted cutting (Light-Medium) Voll- und leicht unterbrochener Schnitt	Most suited for continuous and light interrupted high speed finishing due to heat resistant substrate. Durch sein bruchfestes Substrat die Universalsorte von niedriger bis hoher Schnittgeschwindigkeit mit exzellenter Standzeit.
	YCB131	Interrupted cutting (Heavy) Stark unterbrochener Schnitt	CBN with higher fracture toughness, for interrupted cutting CBN mit exzellenter Bruchzähigkeit im stark unterbrochenen Schnitt.
	YCB211	Cast iron machining, Sintered materials Gussbearbeitung, Sinterwerkstoffe	First choice for high speed finishing of grey cast iron and sintered parts Erste Wahl zum Schlichten mit hohen Schnittgeschwindigkeiten im Guss und Sinterwerkstoffe.

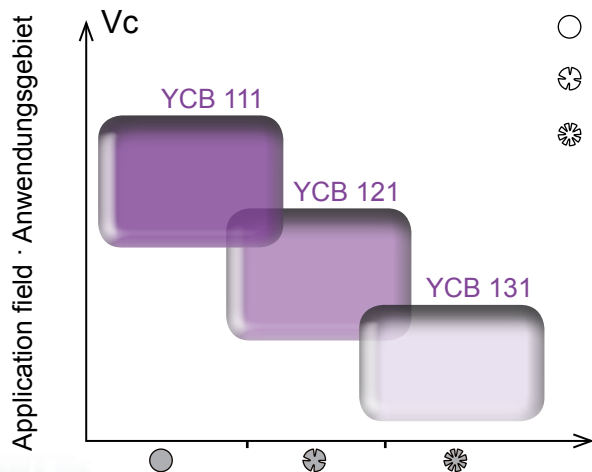

- Continuous cutting
Vollschnitt
- ⊗ Continuous and interrupted cutting
Voll- und leicht unterbrochener Schnitt
- ✱ Interrupted cutting
Stark unterbrochener Schnitt

PCD PCD polycrystalline diamond PCD polycrystalliner Diamand

PCD with high hardness, good wear resistance, low friction coefficient and good heat conductivity, which is appropriate for cutting of non-ferrous metal (such as Cu, Al, Mg and Ti high silicon alloy etc.) and nonmetal materials (such as glass fiber, cermet and enforced plastic etc.)

PCD mit hoher Härte guter Verschleißfähigkeit, und geringer Neugang zur Aufbauschneide, ist besonders geeignet für die Bearbeitung von NE-Metallen und (z.B. Cu, Al, Mg and Ti hochsilicium legierte Werkstoffen und Material wie Fiberglas, Cermets und verstärktes Plastik ect.

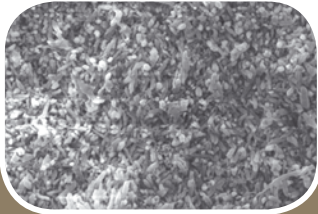

CN1000

CN1000 is Si₃N₄ ceramics grade. Optimal performance against cracking of cutting edge and thermal shocking. Suitable for finishing and semi-finishing of gray cast iron.

CN1000 ist eine Keramik von Si₃N₄. Optimale Eigenschaften gegen Schneidkantenbruch und dynamische Wärmebelastung. Geeignet zum Schlichten und zur mittleren Bearbeitung von Grauguss.

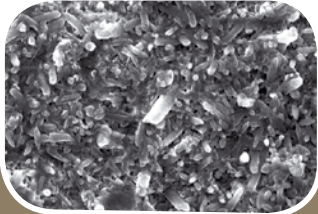

CN2000

CN2000 is Si₃N₄ ceramics grade with good wear-resistance and excellent toughness. Suitable for intermittent and continuous machining of grey cast iron, and Ni-based alloys.

CN2000 is Si₃N₄ Keramiksorte mit hoher Verschleißfestigkeit und ausgezeichneter Zähigkeit. Geeignet für die Bearbeitung von Grauguss mit und ohne Schnittunterbrechungen, sowie Ni-Superlegierungen.

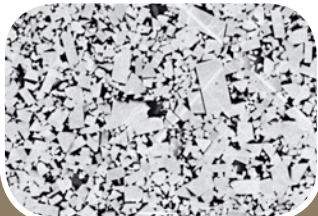

CA1000

CA1000 is the mixed ceramics of Al₂O₃+TiCN. Good performance of wear resistance and safety cutting edge. Suitable for continuous machining of hardened steel and nodular cast iron.

CA1000 ist die Mischkeramik von Al₂O₃+TiCN. Gute Verschleißfestigkeit und Bearbeitungssicherheit oder Zähigkeit. Es ist geeignet zur Bearbeitung von Kugelgraphitguss und gehärtetem Stahl.



■ **Psychical properties · Physikalische Daten**

Grade Sorte	Density·Dichte (g/cm ³)	Hardness · Härte Hv(GPa)	Bending strength/ Biegebruchfestigkeit (MPa)	Fracture toughness Bruchzähigkeit (MPa · m ^{1/2})
CA1000 (Al ₂ O ₃ +TiCN)	4.2	19	≥700	4.5
CN1000 (Si ₃ N ₄)	3.25	16	≥900	7.5
CN2000 (Si ₃ N ₄)	3.25	16	≥900	8





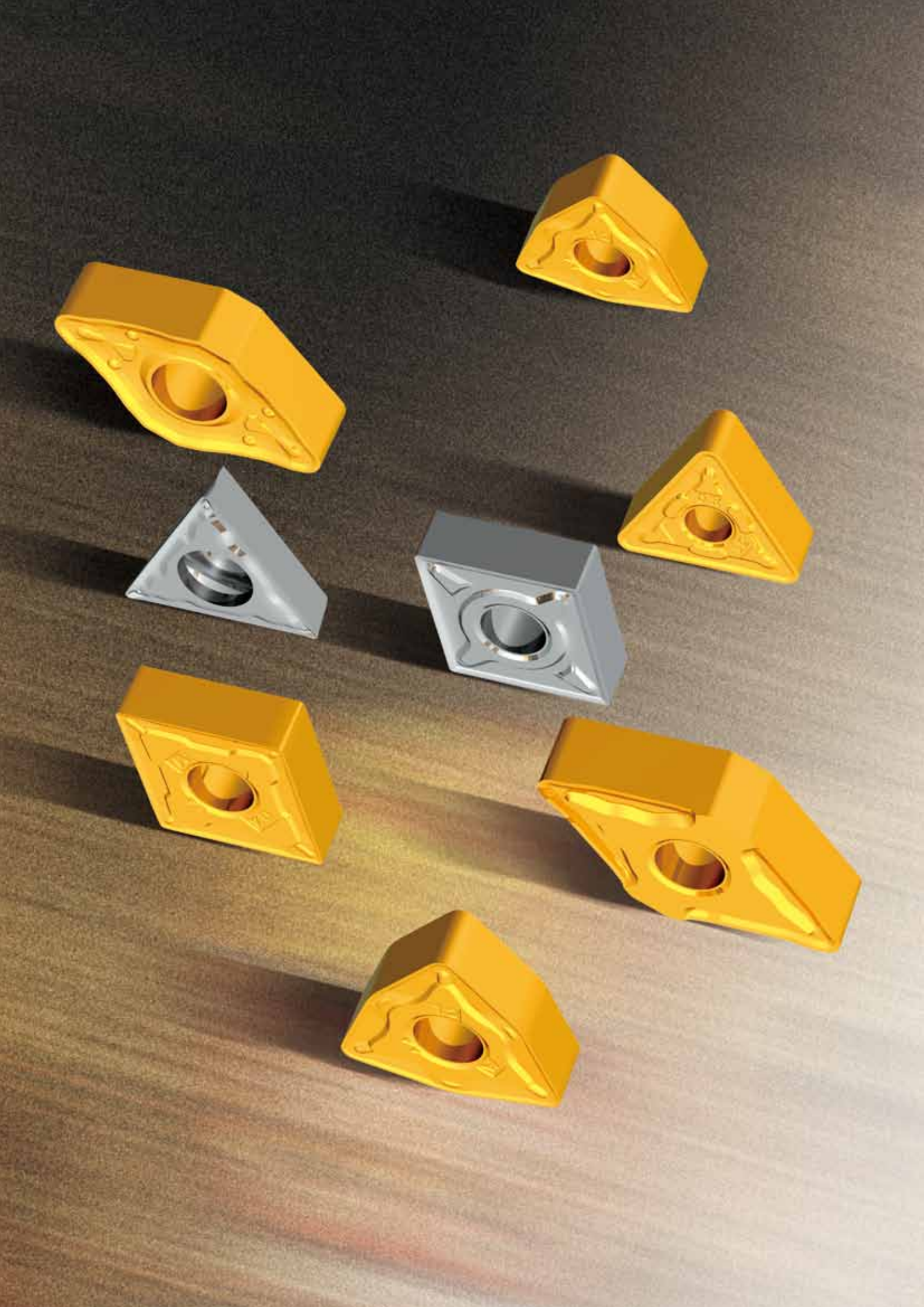











■ **Recommended cutting condition · Empfohlene Schnittdaten**









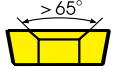

	Workpiece material Werkstückstoff	Application Anwendung	Cutting Speed Schnittgeschw. (m/min)	Feed rate Vorschub (mm/r)	Cutting depth Schnitttiefe (mm)
CA1000	Grey cast iron Malleable cast iron Grauguss	Roughing Schruppen	150-800	0.2-0.5	3.0-6.0
		Finishing Schlichten	200-1200	0.3-0.5	0.1-0.5
	Chilled cast iron Kokillenhartguss	Roughing Schruppen	30-100	0.1-0.2	0.5-1.5
		Finishing Schlichten	50-200	0.05-0.15	0.1-0.5
	Carbon steel, Alloy steel Ball bearing steel unlegierter Stahl, legierter Stahl, Kugellagerstahl	Roughing Schruppen	150-400	0.2-0.5	2.0-5.0
		Finishing Schlichten	200-800	0.05-0.20	0.1-0.5
Hardened Steel Gehärteter Stahl	Roughing Schruppen	20-100	0.1-0.2	0.5-1.5	
	Semi-finishing Mittlere Bearbeitung	40-200	0.05-0.50	0.1-0.5	
	Finishing Schlichten	300-1200	0.05-0.30	0.1-0.5	
CN1000	Grey cast iron Grauguss	Finishing Schlichten	150-1100	0.3-0.8	<5
		Finishing Schlichten	250-1200	0.15-0.4	<1
	Chilled cast iron Kokillenhartguss	Finishing Schlichten	20-250	0.2-0.8	<5
		Finishing Schlichten	60-450	0.1-0.6	<1
CN2000	Ni-based alloys, Ni-Superlegierungen	Finishing Schlichten	150-250	0.2-0.4	<5
		Finishing Schlichten	150-450	0.1-0.2	<1

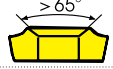

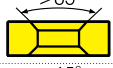

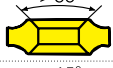
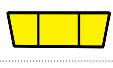
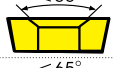
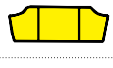

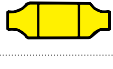



Turning · Drehen



Turning Inserts Code Key · WSP ISO Kennzeichnung

Insert Shape / Schneidplattenform		
 A	 B	 C
 D	 E	 H
 K	 L	 M
 O	 P	 R
 S	 T	 T
 V	 W	Others Z
Insert Shape / Schneidplattenform		

Metric / Metrisch							
Code	Hole/Bohrung	Chipbreaker/ Spanleitstufe	Insert Section/ Plattenform	Code	Hole/Bohrung	Chipbreaker/ Spanleitstufe	Insert Section/ Plattenform
B	✓	---		N	---	---	
H	✓	Single side/ einseitig		R	---	Single side/ einseitig	
C	✓	---		F	---	Double side/ doppelseitig	
J	✓	Double side/ doppelseitig		A	✓	---	
W	✓	---		M	✓	Single side/ einseitig	
T	✓	Single side/ einseitig		G	✓	Double side/ doppelseitig	
Q	✓	---		X	---	---	Special
U	✓	Double side/ doppelseitig				---	
Insert Type / Plattentyp							

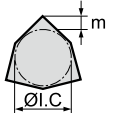
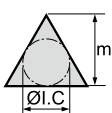

Clearance angle of main cutting edge Freiwinkel der Hauptschneide			
Code	angle / Winkel	Code	angle / Winkel
A	 3°	B	 5°
C	 7°	D	 15°
E	 20°	F	 25°
G	 30°	N	 0°
P	 11°	O	Others

Tolerances / Toleranzklasse											
					(Reference) M class precision (according to shape and size) (mm)						
Code	Tolerance	Incircling Tolerance ØI.C	Tolerance S		incircle	regular triangle	square	80° rhomboid	55° rhomboid	35° rhomboid	round runde
A	±0.005	±0.025	±0.025								
F	±0.005	±0.013	±0.025		6.35	±0.08	±0.08	±0.08	±0.11	±0.16	---
C	±0.013	±0.025	±0.025		9.525	±0.08	±0.08	±0.08	±0.11	±0.16	---
H	±0.013	±0.013	±0.025		12.7	±0.13	±0.13	±0.13	±0.15	---	---
E	±0.025	±0.025	±0.025		15.875	±0.15	±0.15	±0.15	±0.18	---	---
G	±0.025	±0.025	±0.13		19.05	±0.15	±0.15	±0.15	±0.18	---	---
J	±0.005	±0.05±0.13	±0.025		25.4	---	±0.18	---	---	---	---
ØI.C (mm) Incircling tolerance											
K	±0.013	±0.05±0.13	±0.025		incircle	regular triangle	square	80° rhomboid	55° rhomboid	35° rhomboid	round runde
L	±0.025	±0.05±0.13	±0.025		6.35	±0.05	±0.05	±0.05	±0.05	±0.05	---
M	±0.08±0.18	±0.05±0.13	±0.13		9.525	±0.05	±0.05	±0.05	±0.05	±0.05	±0.05
N	±0.08±0.18	±0.05±0.13	±0.025		12.7	±0.08	±0.08	±0.08	±0.08	---	±0.08
U	±0.13±0.38	±0.08±0.25	±0.13		15.875	±0.10	±0.10	±0.10	±0.10	---	±0.10
					19.05	±0.10	±0.10	±0.10	±0.10	---	±0.10
					25.4	---	±0.13	---	---	---	±0.13

Cutting edge length / Schneidenlänge (mm)								
Ø of IC (mm)	Insert Shape/ Plattenform							
	C	D	R	S	T	V	W	K
3.97					06			
5.0			05					
5.56					09			
6.0			06					
6.35	06	07			11	11		
8.0			08					
9.525	09	11	09	09	16	16	06	16
10.0			10					
12.0			12					
12.7	12	15	12	12	22	22	08	
15.875	16		15	15	27			
16.0		19	16					
19.05	19		19	19	33			
20.0			20					
25.0	25	25	25					
25.4			25	25				
31.75			31					
32			32					

Insert thickness / Dicke (mm)	
Thickness / Dicke	
Code	Insert thickness (mm)
00	0.79
T0	0.99
01	1.59
T1	1.98
02	2.38
T2	2.58
03	3.18
T3	3.97
04	4.76
T4	4.96
05	5.96
T5	5.95
06	6.35
T6	6.75
07	7.94
09	9.52
T9	9.72
11	11.11
12	12.70

22 04 08 - DM (ISO)

4 3 2 (inch)

Incircle Innenkreis	
code	diameter (mm)
2	6.35
3	9.525
4	12.7
5	15.875
6	19.05
8	25.4

Thickness Dicke	
code	thickness (mm)
2	3.18
3	4.76
4	6.35
5	7.94
6	9.52

Nose radius Eckenradius	
code	Nose radius (mm)
0	0.2
1	0.4
2	0.8
3	1.2
4	1.6
5	2.0
6	2.4

Nose radius Eckenradius	
code	Radius (mm)
00	no Radius
02	0.2
04	0.4
08	0.8
12	1.2
16	1.6
20	2.0
24	2.4
32	3.2
X	Others
MO	Round Inserts Runde Platten

Code Chipbreakers Spanleitstufen		
DF	DM	DR

Turning · Drehen

Turning Insert Comparison List · WSP Vergleichstabelle

Metric and britain system comparison list of general turning insert/
Vergleichstabelle für allgemeine Drehwendeschneidplatten (Metrisch / Britain System)

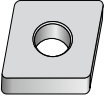
C Type Negative angle/ WSP	(ISO)	(Inch)	Chipbreaker/ Spanleitstufe
Insert shape 	090304	321	-DF -WG -SF -EF -NF -PM -DM -EM -NM -DR -ER -HDR
	090308	322	
	120404	431	
	120408	432	
	120412	433	
	120416	434	
	160608	542	
	160612	543	
	160616	544	
	190608	642	
	190612	643	
	190616	644	
	190624	646	
	250724	856	
	250732	858	
250924	866		
250932	868		

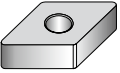
D Type Negative angle/ WSP	(ISO)	(Inch)	Chipbreaker/ Spanleitstufe
Insert shape 	110404	331	-DF -WG -SF -NF -PM -DM -EM -NM -DR -ER -HDR
	110408	332	
	110412	333	
	150404	431	
	150408	432	
	150412	433	
	150604	441	
	150608	442	
	150612	443	
	150616	444	
	190608	542	
	190612	543	

V Type Negative angle/ WSP	(ISO)	(Inch)	Chipbreaker/ Spanleitstufe
Insert shape 	160404	331	-DF -EF -SF -NF -PM -DM -EM -NM
	160408	332	
	160412	333	

R Type Negative angle/ WSP	(ISO)	(Inch)	Chipbreaker/ Spanleitstufe
Insert shape 	0903MO	32	
	1204MO	43	

W Type Negative angle/ WSP	(ISO)	(Inch)	Chipbreaker/ Spanleitstufe
Insert shape 	06T304	3(2.5)1	-DF
	06T308	3(2.5)2	-WG
	06T312	3(2.5)3	-SF
	060404	331	-EF
	060408	332	-NF
	060412	333	-PM
	080404	431	-DM
	080408	432	-EM
	080412	433	-NM
			-DR

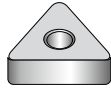
T Type Negative angle/ WSP	(ISO)	(Inch)	Chipbreaker/ Spanleitstufe
Insert shape 	113304	221	-DF -WG -SF -EF -PM -DM -EM -DR -ER -HDR
	110308	222	
	160404	331	
	160408	332	
	160412	333	
	220404	431	
	220408	432	
	220412	433	
	220416	434	
	270608	542	
	270612	543	
	270616	544	

S Type Negative angle/ WSP	(ISO)	(Inch)	Chipbreaker/ Spanleitstufe
Insert shape 	090304	321	-DF -SF -EF -PM -DM -EM -NM -DR -ER -HDR
	090308	322	
	090312	323	
	120404	431	
	120408	432	
	120412	433	
	120416	434	
	150608	542	
	150612	543	
	150616	544	
	190412	633	
	190424	636	
	190612	643	
	190616	644	
	250724	856	
	250732	858	
	250924	866	
	250932	868	

Metric and Britain system comparison list of general turning insert/
Vergleichstabelle für allgemeine Drehwendeschneidplatten (Metrisch / Britain System)

C Type Positive angle/ WSP	(ISO)	(Inch)	Chipbreaker/ Spanleitstufe
Insert shape 	060202	2(1.5)0	-SF -HF -EF -HM -EM -HR -LH
	060204	2(1.5)1	
	060208	2(1.5)2	
	09T302	3(2.5)0	
	09T304	3(2.5)1	
	09T308	3(2.5)2	
	120404	431	
	120408	432	
	120412	433	

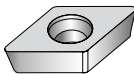
D Type Positive angle/ WSP	(ISO)	(Inch)	Chipbreaker/ Spanleitstufe
Insert shape 	070202	2(1.5)0	-SF -HF -EF -HM -EM -HR -LH
	070204	2(1.5)1	
	070208	2(1.5)2	
	11T302	3(2.5)0	
	11T304	3(2.5)1	
	11T308	3(2.5)2	
	11T312	3(2.5)3	

T Type Positive angle/ WSP	(ISO)	(Inch)	Chipbreaker/ Spanleitstufe
Insert shape 	06T102	1.2(1.2)0	-SF -HF -EF -HM -EM -HR -LH
	06T104	1.2(1.2)1	
	06T108	1.2(1.2)2	
	090202	1.8(1.5)0	
	090204	1.8(1.5)1	
	090208	1.8(1.5)2	
	110202	2(1.5)0	
	110204	2(1.5)1	
	110208	2(1.5)2	
	110302	220	
	110304	221	
	110308	222	
	16T302	30	
	16T304	31	
	16T308	32	
	16T312	33	
	160400	330	
	220408	432	
	220412	433	
	220416	434	
	270408	532	
	270412	533	
	330612	643	
	330616	644	

S Type Positive angle/ WSP	(ISO)	(Inch)	Chipbreaker/ Spanleitstufe
Insert shape 	060204	2(1.5)1	-HF -EF -HM -EM -HR -LH
	09T302	3(2.5)0	
	09T304	3(2.5)1	
	09T308	3(2.5)2	
	120404	431	
	120408	432	
	120412	433	
	150404	531	
	150408	532	
	150412	533	
	190408	632	
	190412	633	
	190416	634	

V Type Positive angle/ WSP	(ISO)	(Inch)	Chipbreaker/ Spanleitstufe
Insert shape 	110202	2(1.5)0	-SF -HF -NF -LH
	110204	2(1.5)1	
	110208	2(1.5)2	
	110302	220	
	110304	221	
	110308	222	
	160402	330	
	160404	331	
	160408	332	
	160412	333	

CN** Negative Insert · Negative WSP

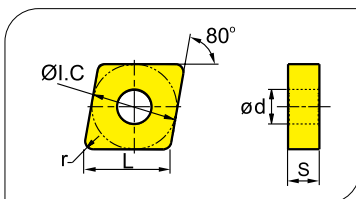

Workpiece Material Werkstoffe	Ideal Machining Condition Gute Bearbeitungsbedingungen			Normal Machining Condition Normale Bearbeitungsbedingungen			Unfavorable Machining Condition Ungünstige Bearbeitungsbedingungen			
	P	M	K	N	S	P	M	K	N	S
P Steel / Stahl	●	●	●	●	●	●	●	●	●	●
M Stainless Steel / Rostfreier Stahl	●	●	●	●	●	●	●	●	●	●
K Cast iron / Gusseisen	●	●	●	●	●	●	●	●	●	●
N Non-ferrite material / Ne Metalle	●	●	●	●	●	●	●	●	●	●
S Heat-resistant steel / Warmfester Stahl	●	●	●	●	●	●	●	●	●	●

Insert Shape Schneidplattenform	Type · Typ	Dimension (mm) Abmessung					Coated Carbide Beschichtetes Hartmetall										Cermet unbeschichtet	Cermet Coated beschicht. Cermet	Uncoated Carbide unbeschicht. Hartmetall										
		L	I.C	S	d	r	YBC151	YBC251	YBC351	YBG102	YBG202	YBG205	YBG302	YBM151	YBM251	YBM351			YBD052	YBD102	YBD151	YBD152	YBD252	YNG151	YNG151C	YC10	YC40	YD051	YD101
NF Finishing Schlichten	CNEG120404-NF	12.9	12.7	4.76	5.16	0.4			●																				
	CNEG120408-NF	12.9	12.7	4.76	5.16	0.8			●																				
	CNEG120412-NF	12.9	12.7	4.76	5.16	1.2			○																				
PM Medium Cut/ Mittl. Bearb.	CNMG090304-PM	9.7	9.525	3.18	3.81	0.4		●																					
	CNMG090308-PM	9.7	9.525	3.18	3.81	0.8		●																					
	CNMG120404-PM	12.9	12.7	4.76	5.16	0.4	●	●						○		●		●											
	CNMG120408-PM	12.9	12.7	4.76	5.16	0.8	●	●						○		●	●	●	●	○									○
	CNMG120412-PM	12.9	12.7	4.76	5.16	1.2	●	●						○		●	●	●	●	●									
	CNMG120416-PM	12.9	12.7	4.76	5.16	1.6	○	●								●	●	●	●	○									
	CNMG160608-PM	16.1	15.875	6.35	6.35	0.8		●								○	○	○											
	CNMG160612-PM	16.1	15.875	6.35	6.35	1.2	○	●								○	●	○	●	○									
	CNMG160616-PM	16.1	15.875	6.35	6.35	1.6	○	●								○	○	○											
	CNMG190608-PM	19.3	19.05	6.35	7.94	0.8		●								○													
	CNMG190612-PM	19.3	19.05	6.35	7.94	1.2		●								○	○		●										
CNMG190616-PM	19.3	19.05	6.35	7.94	1.6		●								○	○	○												

Tool holder / Klemmhalter



Page Seite A158 A159 A170 A171 A216

Insert code key
ISO Code

A42-A43

Grade selection reference
Sortenauswahl

A14/A31-A40

chip breaker selection reference
Spanbrecherauswahl

A24-A30

Recommended cutting parameters
Empfohlene Schnittparameter

A249-A253

CN** Negative Insert-Negative WSP

● Ideal Machining Condition / Gute Bearbeitungsbedingungen
⊙ Normal Machining Condition / Normale Bearbeitungsbedingungen
⊛ Unfavorable Machining Condition / Ungünstige Bearbeitungsbedingungen

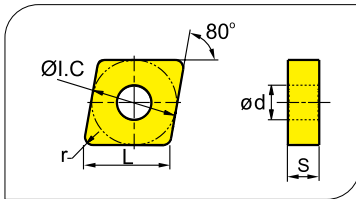

Workpiece Material / Werkstoffe	P	M	K	N	S
Steel / Stahl	●	●	●	●	●
Stainless Steel / Rostfreier Stahl	●	●	●	●	●
Cast iron / Gusseisen	●	●	●	●	●
Non-ferrous material / Ne Metalle	●	●	●	●	●
Heat-resistant steel / Warmfester Stahl	●	●	●	●	●

Insert Shape / Schneidplattenform	Type · Typ	Dimension (mm) / Abmessung					Coated Carbide / Beschichtetes Hartmetall										Cermet unbeschichtet	Cermet Coated / beschicht. Cermet	Uncoated Carbide / unbeschicht. Hartmetall									
		L	I.C	S	d	r	YBC151	YBC251	YBC351	YBG102	YBG202	YBG205	YBG302	YBM151	YBM251	YBM351			YBD052	YBD102	YBD151	YBD152	YBD252	YNG151	YNG151C	YC10	YC40	YD051
NM Medium Cut / Mittl. Bearb.	CNMG120404-NM	12.9	12.7	4.76	5.16	0.4																						
	CNMG120408-NM	12.9	12.7	4.76	5.16	0.8				●																	○	
	CNMG120412-NM	12.9	12.7	4.76	5.16	1.2				●																		
DR Roughing / Schruppen	CNMG120408-DR	12.9	12.7	4.76	5.16	0.8	●	●	●					○		●		●										
	CNMG120412-DR	12.9	12.7	4.76	5.16	1.2	●	●	●							●	●	●										
	CNMG120416-DR	12.9	12.7	4.76	5.16	1.6	●	●	●							●	●	●										
	CNMG160608-DR	16.1	15.875	6.35	6.35	0.8			●							●		○										
	CNMG160612-DR	16.1	15.875	6.35	6.35	1.2	●	●	●								○	●										
	CNMG160616-DR	16.1	15.875	6.35	6.35	1.6	●	●	●								○	○										
	CNMG190608-DR	19.3	15.875	6.35	7.94	0.8			●								●		●									
	CNMG190612-DR	19.3	19.05	6.35	7.94	1.2	●	●	●									○	●									
	CNMG190616-DR	19.3	19.05	6.35	7.94	1.6	●	●	●									●	●									
CNMG190624-DR	19.3	19.05	6.35	7.94	2.4	●	●	●									○	○										

Tool holder / Klemmhalter



Page/Seite A158 A159 A170 A171 A216

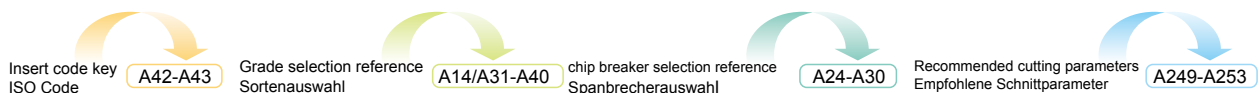

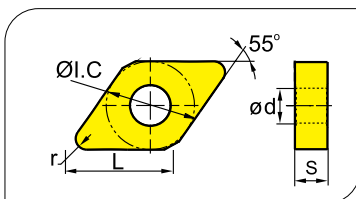

DN** Negative Insert-Negative WSP



● Ideal Machining Condition / Gute Bearbeitungsbedingungen
● Normal Machining Condition / Normale Bearbeitungsbedingungen
● Unfavorable Machining Condition / Ungünstige Bearbeitungsbedingungen

Workpiece Material / Werkstoffe	P	M	K	N	S
Steel / Stahl	●	●	●	●	●
Stainless Steel / Rostfreier Stahl	●	●	●	●	●
Cast iron / Gusseisen	●	●	●	●	●
Non-ferrous material / Ne Metalle	●	●	●	●	●
Heat-resistant steel / Warmfester Stahl	●	●	●	●	●

Insert Shape / Schneidplattenform	Type · Typ	Dimension (mm) / Abmessung					Coated Carbide / Beschichtetes Hartmetall										Cermet unbeschichtet	Cermet Coated / Beschicht. Cermet	Uncoated Carbide / unbeschicht. Hartmetall									
		L	I.C	S	d	r	YBC151	YBC251	YBC351	YBG102	YBG202	YBG205	YBG302	YBM151	YBM251	YBM351			YBD052	YBD102	YBD151	YBD152	YBD252	YNG151	YNG151C	YC10	YC40	YD051
 Medium Cut / Mittl. Bearb.	DNMG150412-PM	15.5	12.7	4.76	5.16	1.2	●																					
	DNMG150416-PM	15.5	12.7	4.76	5.16	1.6	○																					
	DNMG150604-PM	15.5	12.7	6.35	5.16	0.4	●	●	○					○	●	●		○										
	DNMG150608-PM	15.5	12.7	6.35	5.16	0.8	●	●	●					○	●	●		●										
	DNMG150612-PM	15.5	12.7	6.35	5.16	1.2	●	●	●					●	○	●		●										
DNMG150616-PM	15.5	12.7	6.35	5.16	1.6	●											●											
 Medium Cut / Mittl. Bearb.	DNMG110404-DM	11.6	9.525	4.76	3.81	0.4	●	●	○					●							●							
	DNMG110408-DM	11.6	9.525	4.76	3.81	0.8	●	●	●					○														
	DNMG110412-DM	11.6	9.525	4.76	3.81	1.2			○																			
	DNMG150404-DM	15.5	12.7	4.76	5.16	0.4	●	●														○						
	DNMG150408-DM	15.5	12.7	4.76	5.16	0.8	●	●						○								●					○	
	DNMG150412-DM	15.5	12.7	4.76	5.16	1.2	○	○						○														
	DNMG150416-DM	15.5	12.7	4.76	5.16	1.6																						
	DNMG150604-DM	15.5	12.7	6.35	5.16	0.4	●	●	○				○	●	●							○						
	DNMG150608-DM	15.5	12.7	6.35	5.16	0.8	●	●	●				○	○	●							●						
	DNMG150612-DM	15.5	12.7	6.35	5.16	1.2	●	●	○					○														
DNMG150616-DM	15.5	12.7	6.35	5.16	1.6	●	●																					

Tool holder / Klemmhalter



Page/Seite A160 A161 A172 A173 A218 A219

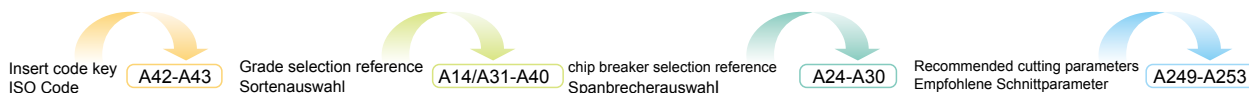

SN** Negative Insert · Negative WSP

● Ideal Machining Condition / Gute Bearbeitungsbedingungen
⊗ Normal Machining Condition / Normale Bearbeitungsbedingungen
⊗ Unfavorable Machining Condition / Ungünstige Bearbeitungsbedingungen

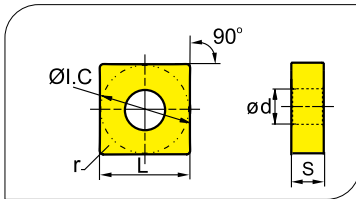

Workpiece Material / Werkstoffe	P	M	K	N	S
Steel / Stahl	●	●	●	●	●
Stainless Steel / Rostfreier Stahl	●	●	●	●	●
Cast iron / Gusseisen	●	●	●	●	●
Non-ferrite material / Ne Metalle	●	●	●	●	●
Heat-resistant steel / Warmfester Stahl	●	●	●	●	●

Insert Shape / Schneidplattenform	Type · Typ	Dimension (mm) / Abmessung					Coated Carbide / Beschichtetes Hartmetall										Cermet unbeschichtet	Cermet Coated / beschicht. Cermet	Uncoated Carbide / unbeschicht. Hartmetall									
		L	I.C	S	d	r	YBC151	YBC251	YBC351	YBG102	YBG202	YBG205	YBG302	YBM151	YBM251	YBM351			YBD052	YBD102	YBD151	YBD152	YBD252	YNG151	YNG151C	YC10	YC40	YD051
DF Finishing Schlichten	SNMG090304-DF	9.525	9.525	3.18	3.81	0.4																						
	SNMG090308-DF	9.525	9.525	3.18	3.81	0.8																						
	SNMG120404-DF	12.7	12.7	4.76	5.16	0.4																						
	SNMG120408-DF	12.7	12.7	4.76	5.16	0.8	●	●																				
	SNMG120412-DF	12.7	12.7	4.76	5.16	1.2	●	●																				
EF Finishing Schlichten	SNMG090304-EF	9.525	9.525	3.18	3.81	0.4				●	○																	
	SNMG090308-EF	9.525	9.525	3.18	3.81	0.8				●	○																	
	SNMG090312-EF	9.525	9.525	3.18	3.81	1.2						○																
	SNMG120404-EF	12.7	12.7	4.76	5.16	0.4					○	●																
	SNMG120408-EF	12.7	12.7	4.76	5.16	0.8					●	○																
	SNMG120412-EF	12.7	12.7	4.76	5.16	1.2					●	○	●															
	SNMG150608-EF	15.875	15.875	6.35	6.35	0.8					○	○																
SNMG150612-EF	15.875	15.875	6.35	6.35	1.2							○																

Tool holder / Klemmhalter

PSBNR/L Kr:75° Page/Seite A162	PSDNN Kr:45° A163	PSKNR/L Kr:75° A164	PSSNR/L Kr:45° A165	MSBNR/L Kr:75° A174	MSRNR/L Kr:75° A175	MSKNR/L Kr:75° A176
MSDNN Kr:45° Page/Seite A177	PSKNR/L Kr:75° A221					

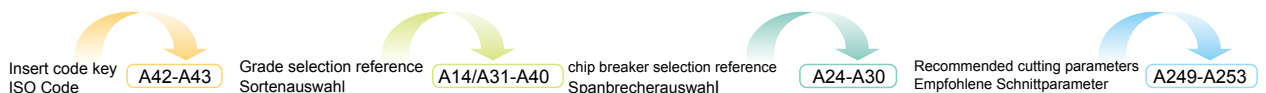

SN** Negative Insert-Negative WSP

● Ideal Machining Condition / Gute Bearbeitungsbedingungen
 ● Normal Machining Condition / Normale Bearbeitungsbedingungen
 ● Unfavorable Machining Condition / Ungünstige Bearbeitungsbedingungen

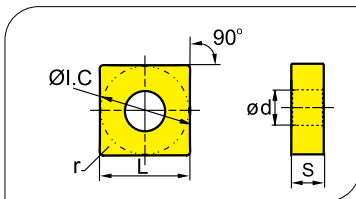

Workpiece Material / Werkstoffe	P	M	K	N	S
Steel / Stahl	●●●●●●●●●●	●●●●●●●●●●	●●●●●●●●●●	●●●●●●●●●●	●●●●●●●●●●
Stainless Steel / Rostfreier Stahl	●●●●●●●●●●	●●●●●●●●●●	●●●●●●●●●●	●●●●●●●●●●	●●●●●●●●●●
Cast iron / Gusseisen	●●●●●●●●●●	●●●●●●●●●●	●●●●●●●●●●	●●●●●●●●●●	●●●●●●●●●●
Non-ferrous material / Ne Metalle	●●●●●●●●●●	●●●●●●●●●●	●●●●●●●●●●	●●●●●●●●●●	●●●●●●●●●●
Heat-resistant steel / Warmfester Stahl	●●●●●●●●●●	●●●●●●●●●●	●●●●●●●●●●	●●●●●●●●●●	●●●●●●●●●●

Insert Shape / Schneidplattenform	Type · Typ	Dimension (mm) / Abmessung					Coated Carbide / Beschichtetes Hartmetall										Cermet unbeschichtet	Cermet Coated beschicht. Cermet	Uncoated Carbide unbeschicht. Hartmetall									
		L	I.C	S	d	r	YBC151	YBC251	YBC351	YBG102	YBG202	YBG205	YBG302	YBM151	YBM251	YBM351			YBD052	YBD102	YBD151	YBD152	YBD252	YNG151	YNG151C	YC10	YC40	YD051
DM 	SNMG090304-DM	9.525	9.525	3.18	3.81	0.4	○																					
	SNMG090308-DM	9.525	9.525	3.18	3.81	0.8	●	●	○																			
	SNMG120404-DM	12.7	12.7	4.76	5.16	0.4	●	●						●	○			○				●						
	SNMG120408-DM	12.7	12.7	4.76	5.16	0.8	●	●	●					●	●	○			○									
	SNMG120412-DM	12.7	12.7	4.76	5.16	1.2	●	●	●	○				○	●	○						○						
	SNMG120416-DM	12.7	12.7	4.76	5.16	1.6	○	●	○																			
	SNMG150608-DM	15.875	15.875	6.35	6.35	0.8	○	●																				
	SNMG150612-DM	15.875	15.875	6.35	6.35	1.2	●	●	○																			
	SNMG150616-DM	15.875	15.875	6.35	6.35	1.6		○																				
	SNMG190612-DM	19.05	19.05	6.35	7.94	1.2	●	●	○					●	○													
	SNMG190616-DM	19.05	19.05	6.35	7.94	1.6		●	●						○	○												
EM 	SNMG120404-EM	12.7	12.7	4.76	5.16	0.4				○	●																	
	SNMG120408-EM	12.7	12.7	4.76	5.16	0.8				●	●			●	○													
	SNMG120412-EM	12.7	12.7	4.76	5.16	1.2				●	○			●	○													
	SNMG120416-EM	12.7	12.7	4.76	5.16	1.6						○																
	SNMG150612-EM	15.875	15.875	6.35	6.35	1.2						○																
	SNMG150616-EM	15.875	15.875	6.35	6.35	1.6						○																

Tool holder / Klemmhalter

PSBNR/L Kr:75° 	PSDNN Kr:45° 	PSKNR/L Kr:75° 	PSSNR/L Kr:45° 	MSBNR/L Kr:75° 	MSRNR/L Kr:75° 	MSKNR/L Kr:75°
Page/Seite A162	A163	A164	A165	A174	A175	A176
MSDNN Kr:45° 	PSKNR/L Kr:75° 					
Page/Seite A177	A221					

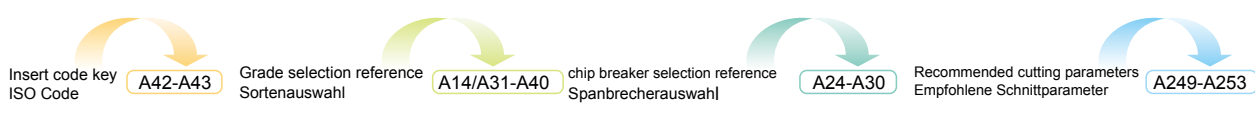

Turning · Drehen

A



General Turning · Allgemeine Drehbearbeitung

SN** Negative Insert-Negative WSP

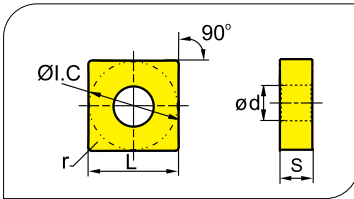
● Ideal Machining Condition / Gute Bearbeitungsbedingungen
 ● Normal Machining Condition / Normale Bearbeitungsbedingungen
 ● Unfavorable Machining Condition / Ungünstige Bearbeitungsbedingungen



Workpiece Material / Werkstoffe	P	M	K	N	S
Steel / Stahl	●	●	●	●	●
Stainless Steel / Rostfreier Stahl	●	●	●	●	●
Cast iron / Gusseisen	●	●	●	●	●
Non-ferrous material / Ne Metalle	●	●	●	●	●
Heat-resistant steel / Warmfester Stahl	●	●	●	●	●

Insert Shape / Schneidplattenform	Type · Typ	Dimension (mm) / Abmessung					Coated Carbide / Beschichtetes Hartmetall										Cerm. unbeschichtet	Cerm. Coated / beschicht. Cerm.	Uncoated Carbide / unbeschicht. Hartmetall									
		L	I.C.	S	d	r	YBC151	YBC251	YBC351	YBG102	YBG202	YBG205	YBG302	YBM151	YBM251	YBM351			YBD052	YBD102	YBD151	YBD162	YBD252	YNG151	YNG151C	YC10	YC40	YD051
 Medium Cut / Mittl. Bearb.	SNMG120408-NM	12.7	12.7	4.76	5.16	0.8			●																			
	SNMG120412-NM	12.7	12.7	4.76	5.16	1.2																						
 Roughing / Schruppen	SNMG120408-DR	12.7	12.7	4.76	5.16	0.8	●	●	●								●	●										
	SNMG120412-DR	12.7	12.7	4.76	5.16	1.2	●	●	●								●	●	○									
	SNMG120416-DR	12.7	12.7	4.76	5.16	1.6	○	●	○								●	●										
	SNMG150608-DR	15.875	15.875	6.35	6.35	0.8		○											○									
	SNMG150612-DR	15.875	15.875	6.35	6.35	1.2	●	●	●								●	●										
	SNMG150616-DR	15.875	15.875	6.35	6.35	1.6		●	●								●	○										
	SNMG150624-DR	15.875	15.875	6.35	6.35	2.4		○																				
	SNMG190612-DR	19.05	19.05	6.35	7.94	1.2	○	●	●										●									
	SNMG190616-DR	19.05	19.05	6.35	7.94	1.6	●	●	●									○	●									
SNMG190624-DR	19.05	19.05	6.35	7.94	2.4	○	●	●																				
 Roughing / Schruppen	SNMM120408-DR	12.7	12.7	4.76	5.16	0.8																						
	SNMM120412-DR	12.7	12.7	4.76	5.16	1.2																						
	SNMM120416-DR	12.7	12.7	4.76	5.16	1.6																						
	SNMM150608-DR	15.875	15.875	6.35	6.35	0.8																						
	SNMM150612-DR	15.875	15.875	6.35	6.35	1.2		○																				
	SNMM150616-DR	15.875	15.875	6.35	6.35	1.6		●																				
	SNMM190608-DR	19.05	19.05	6.35	7.94	0.8		○																				

Tool holder / Klemmhalter



Page/Seite A162 A163 A164 A165 A174 A175 A176



Page/Seite A177 A221



● Ex Stock / ab Lager ○ On demand / auf Anfrage

SN** Negative Insert · Negative WSP

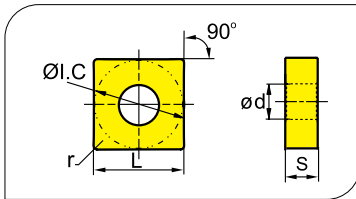
● Ideal Machining Condition / Gute Bearbeitungsbedingungen
 ● Normal Machining Condition / Normale Bearbeitungsbedingungen
 ● Unfavorable Machining Condition / Ungünstige Bearbeitungsbedingungen



Workpiece Material / Werkstoffe	P	M	K	N	S
Steel / Stahl	●	●	●	●	●
Stainless Steel / Rostfreier Stahl	●	●	●	●	●
Cast iron / Gusseisen	●	●	●	●	●
Non-ferrous material / Ne Metalle	●	●	●	●	●
Heat-resistant steel / Warmfester Stahl	●	●	●	●	●

Insert Shape / Schneidplattenform	Type · Typ	Dimension (mm) / Abmessung					Coated Carbide / Beschichtetes Hartmetall										Cermet unbeschichtet	Cermet Coated beschicht. Cermet	Uncoated Carbide unbeschicht. Hartmetall									
		L	I.C	S	d	r	YBC151	YBC251	YBC351	YBG102	YBG202	YBG205	YBG302	YBM151	YBM251	YBM351			YBD052	YBD102	YBD151	YBD152	YBD252	YNG151	YNG151C	YC10	YC40	YD051
 Roughing / Schruppen	SNMM190612-DR	19.05	19.05	6.35	7.94	1.2	○	●	○																			
	SNMM190616-DR	19.05	19.05	6.35	7.94	1.6	●	●	○																			
	SNMM190624-DR	19.05	19.05	6.35	7.94	2.4	●	●	●																			
	SNMM250724-DR	25.4	25.4	7.94	9.12	2.4		●	●																			
	SNMM250924-DR	25.4	25.4	9.525	9.12	2.4		●	●																			
 Roughing / Schruppen	SNMG120408-ER	12.7	12.7	4.76	5.16	0.8																						
	SNMG120412-ER	12.7	12.7	4.76	5.16	1.2																						
	SNMG150608-ER	15.875	15.875	6.35	6.35	0.8																						
	SNMG150612-ER	15.875	15.875	6.35	6.35	1.2							●															
	SNMG190612-ER	19.05	19.05	6.35	7.94	1.2							●															
 Roughing / Schruppen	SNMM250724-ER	25.4	25.4	7.94	9.12	2.4							●															
	SNMM250732-ER	25.4	25.4	7.94	9.12	3.2		○																				
	SNMM250924-ER	25.4	25.4	9.525	9.12	2.4		○				○	●															
	SNMM250932-ER	25.4	25.4	9.525	9.12	3.2		○					●															

Tool holder / Klemmhalter



Page/Seite A162 A163 A164 A165 A174 A175 A176



Page/Seite A177 A221

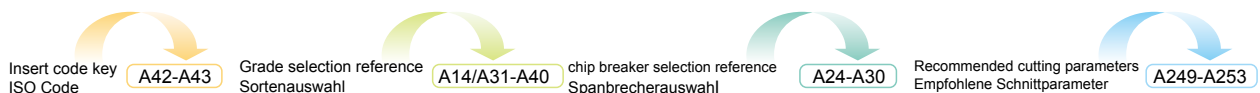

Turning · Drehen

Cemented carbide and cermet Inserts · Hartmetall und Cermet WSP

SN** Negative Insert-Negative WSP

● Ideal Machining Condition / Gute Bearbeitungsbedingungen
 ● Normal Machining Condition / Normale Bearbeitungsbedingungen
 ● Unfavorable Machining Condition / Ungünstige Bearbeitungsbedingungen

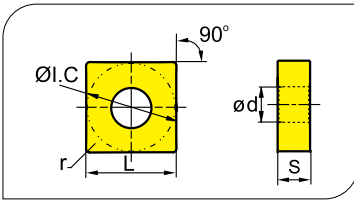

Workpiece Material / Werkstoffe	P	M	K	N	S
Steel / Stahl	●	●	●	●	●
Stainless Steel / Rostfreier Stahl	●	●	●	●	●
Cast iron / Gusseisen	●	●	●	●	●
Non-ferrite material / Ne Metalle	●	●	●	●	●
Heat-resistant steel / Warmfester Stahl	●	●	●	●	●

Insert Shape / Schneidplattenform	Type · Typ	Dimension (mm) / Abmessung					Coated Carbide / Beschichtetes Hartmetall										Cermet unbeschichtet	Cermet Coated / beschicht. Cermet	Uncoated Carbide / unbeschicht. Hartmetall									
		L	I.C	S	d	r	YBC151	YBC251	YBC351	YBG102	YBG202	YBG205	YBG302	YBM151	YBM251	YBM351			YBD052	YBD102	YBD151	YBD152	YBD252	YNG151	YNG151C	YC10	YC40	YD051
 HDR Roughing / Schruppen	SNMM120408-HDR	12.7	12.7	4.76	5.16	0.8	○	●	●																			
	SNMM120412-HDR	12.7	12.7	4.76	5.16	1.2	●	●	●				●															
	SNMM120416-HDR	12.7	12.7	4.76	5.16	1.6			○																			
	SNMM150608-HDR	15.875	15.875	6.35	6.35	0.8		●	○																			
	SNMM150612-HDR	15.875	15.875	6.35	6.35	1.2	●	●	●																			
	SNMM150616-HDR	15.875	15.875	6.35	6.35	1.6		●	○																			
	SNMM150624-HDR	15.875	15.875	6.35	6.35	2.4																						
	SNMM190608-HDR	19.05	19.05	6.35	7.94	0.8																						
	SNMM190612-HDR	19.05	19.05	6.35	7.94	1.2		●																				
	SNMM190616-HDR	19.05	19.05	6.35	7.94	1.6	●	●	○																			
	SNMM190624-HDR	19.05	19.05	6.35	7.94	2.4		○																				
	SNMM250724-HDR	25.4	25.4	7.94	9.12	2.4		○	●																			
	SNMM250924-HDR	25.4	25.4	9.525	9.12	2.4		○																				

Tool holder / Klemmhalter

PSBNR/L Kr:75°  Page/Seite A162	PSDNN Kr:45°  A163	PSKNR/L Kr:75°  A164	PSSNR/L Kr:45°  A165	MSBNR/L Kr:75°  A174	MSRNR/L Kr:75°  A175	MSKNR/L Kr:75°  A176
MSDNN Kr:45°  Page/Seite A177	PSKNR/L Kr:75°  A221					

● Ex Stock / ab Lager ○ On demand / auf Anfrage

Turning · Drehen

Cemented carbide and cermet Inserts · Hartmetall und Cermet WSP

A

General Turning · Allgemeine Drehbearbeitung

TN** Negative Insert · Negative WSP

● Ideal Machining Condition / Gute Bearbeitungsbedingungen
 ● Normal Machining Condition / Normale Bearbeitungsbedingungen
 ● Unfavorable Machining Condition / Ungünstige Bearbeitungsbedingungen

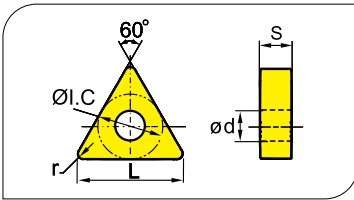

Workpiece Material / Werkstoffe	P	M	K	N	S
Steel / Stahl	●	●	●	●	●
Stainless Steel / Rostfreier Stahl	●	●	●	●	●
Cast iron / Gusseisen	●	●	●	●	●
Non-ferrite material / Ne Metalle	●	●	●	●	●
Heat-resistant steel / Warmfester Stahl	●	●	●	●	●

Insert Shape / Schneidplattenform	Type · Typ	Dimension (mm) / Abmessung					Coated Carbide / Beschichtetes Hartmetall										Cermet unbeschichtet	Cermet Coated / beschicht. Cermet	Uncoated Carbide / unbeschicht. Hartmetall									
		L	I.C	S	d	r	YBC151	YBC251	YBC351	YBG102	YBG202	YBG205	YBG302	YBM151	YBM251	YBM351			YBD052	YBD102	YBD151	YBD152	YBD252	YNG151	YNG151C	YC10	YC40	YD051
EM Medium Cut / Mittl. Bearb.	TNMG160404-EM	16.5	9.525	4.76	3.81	0.4					●	●																
	TNMG160408-EM	16.5	9.525	4.76	3.81	0.8					●	●		●														
	TNMG160412-EM	16.5	9.525	4.76	3.81	1.2					●	○																
	TNMG220408-EM	22	12.7	4.76	5.16	0.8					●	●		●														
	TNMG220412-EM	22	12.7	4.76	5.16	1.2					●	●		●														
	TNMG220416-EM	22	12.7	4.76	5.16	1.6					●	●		●														
DR Roughing / Schruppen	TNMG160408-DR	16.5	9.525	4.76	3.81	0.8		●									●		●									
	TNMG160412-DR	16.5	9.525	4.76	3.81	1.2	●	●	●								●		●									
	TNMG220408-DR	22	12.7	4.76	5.16	0.8		●									○		○									
	TNMG220412-DR	22	12.7	4.76	5.16	1.2	○	●	●									○		●								
	TNMG220416-DR	22	12.7	4.76	5.16	1.6	●	●	○									○		●								
	TNMG270608-DR	27.5	15.875	6.35	6.35	0.8			○																			
	TNMG270612-DR	27.5	15.875	6.35	6.35	1.2			○																			
	TNMG270616-DR	27.5	15.875	6.35	6.35	1.6	○																					

Tool holder / Klemmhalter

PTFNR/L Kr:90° 	PTTNR/L Kr:60° 	PTGNR/L Kr:90° 	MTGNR/L Kr:90° 	MTJNR/L Kr:93° 	MTFNR/L Kr:90° 	PTFNR/L Kr:90°
Page/Seite A166	A167	A168	A178	A179	A180	A222

● Ex Stock / ab Lager ○ On demand / auf Anfrage

TN** Negative Insert-Negative WSP

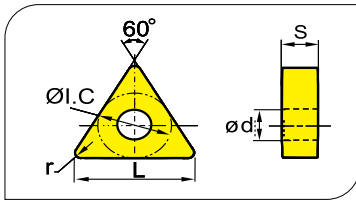

Workpiece Material / Werkstoffe	Ideal Machining Condition / Gute Bearbeitungsbedingungen			Normal Machining Condition / Normale Bearbeitungsbedingungen			Unfavorable Machining Condition / Ungünstige Bearbeitungsbedingungen		
	P	M	K	P	M	K	P	M	K
P Steel / Stahl	●	●	●	●	●	●	●	●	●
M Stainless Steel / Rostfreier Stahl		●	●	●	●	●	●	●	●
K Cast iron / Gusseisen							●	●	●
N Non-ferrite material / Ne Metalle									●
S Heat-resistant steel / Warmfester Stahl				●	●	●			

Insert Shape / Schneidplattenform	Type · Typ	Dimension (mm) / Abmessung					Coated Carbide / Beschichtetes Hartmetall										Cermet unbeschichtet	Cermet Coated / Beschicht. Cermet	Uncoated Carbide / unbeschicht. Hartmetall									
		L	I.C	S	d	r	YBC151	YBC251	YBC351	YBG102	YBG202	YBG205	YBG302	YBM151	YBM251	YBM351			YBD052	YBD102	YBD151	YBD152	YBD252	YNG151	YNG151C	YC10	YC40	YD051
DR Roughing / Schruppen	TNMM160408-DR	16.5	9.525	4.76	3.81	0.8	●	●	●																			
	TNMM160412-DR	16.5	9.525	4.76	3.81	1.2		●																				
	TNMM220408-DR	22	12.7	4.76	5.16	0.8		●	●																			
	TNMM220412-DR	22	12.7	4.76	5.16	1.2		●	●																			
	TNMM220416-DR	22	12.7	4.76	5.16	1.6		○	●																			
	TNMM270612-DR	27.5	15.875	4.76	5.16	1.2																						
TNMM270616-DR	27.5	15.875	4.76	5.16	1.6																							
ER Roughing / Schruppen	TNMG160408-ER	16.5	9.525	4.76	3.81	0.8								○														
	TNMG160412-ER	16.5	9.525	4.76	3.81	1.2								○														
	TNMG220408-ER	22	12.7	4.76	5.16	0.8								○														
	TNMG220412-ER	22	12.7	4.76	5.16	1.2								●														

Tool holder / Klemmhalter

PTFNR/L Kr:90° 	PTTNR/L Kr:60° 	PTGNR/L Kr:90° 	MTGNR/L Kr:90° 	MTJNR/L Kr:93° 	MTFNR/L Kr:90° 	PTFNR/L Kr:90°
Page/Seite A166	A167	A168	A178	A179	A180	A222

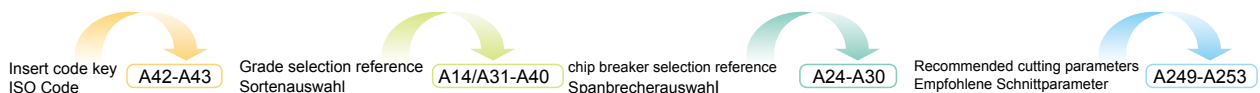

Turning · Drehen

Cemented carbide and cermet Inserts · Hartmetall und Cermet WSP

A



General Turning · Allgemeine Drehbearbeitung

WN** Negative Insert · Negative WSP

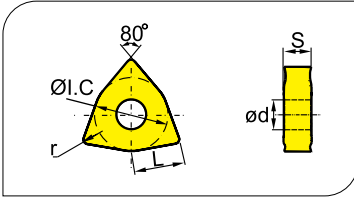
● Ideal Machining Condition / Gute Bearbeitungsbedingungen
 ◐ Normal Machining Condition / Normale Bearbeitungsbedingungen
 ☼ Unfavorable Machining Condition / Ungünstige Bearbeitungsbedingungen



Workpiece Material / Werkstoffe	P	M	K	N	S
Steel / Stahl	●	●	●	●	●
Stainless Steel / Rostfreier Stahl	●	●	●	●	●
Cast iron / Gusseisen	●	●	●	●	●
Non-ferrous material / Ne Metalle	●	●	●	●	●
Heat-resistant steel / Warmfester Stahl	●	●	●	●	●

Insert Shape / Schneidplattenform	Type · Typ	Dimension (mm) / Abmessung					Coated Carbide / Beschichtetes Hartmetall										Cermet unbeschichtet	Cermet Coated / beschicht. Cermet	Uncoated Carbide / unbeschicht. Hartmetall									
		L	I.C	S	d	r	YBC151	YBC251	YBC351	YBG102	YBG202	YBG205	YBG302	YBM151	YBM251	YBM351			YBD052	YBD102	YBD151	YBD152	YBD252	YNG151	YNG151C	YC10	YC40	YD051
PM  Medium Cut / Mittl. Bearb.	WNMG060408-PM	6.5	9.525	4.76	3.81	0.8	●	●									●	●	●									
	WNMG060412-PM	6.5	9.525	4.76	3.81	1.2	●	●									●	●	●									
	WNMG080404-PM	8.7	12.7	4.76	5.16	0.4	●	●	○								●	●	●									
	WNMG080408-PM	8.7	12.7	4.76	5.16	0.8	●	●	●								●	●	●									
	WNMG080412-PM	8.7	12.7	4.76	5.16	1.2	●	●	●								●	●	●									
	WNMG080416-PM	8.7	12.7	4.76	5.16	1.6		●	○								○	○	●									
DM  Medium Cut / Mittl. Bearb.	WNMG06T304-DM	6.5	9.525	3.97	3.81	0.4																						
	WNMG06T308-DM	6.5	9.525	3.97	3.81	0.8																						
	WNMG06T312-DM	6.5	9.525	3.97	3.81	1.2																						
	WNMG060408-DM	6.5	9.525	4.76	3.81	0.8	●	●	○				●	●	○													
	WNMG060412-DM	6.5	9.525	4.76	3.81	1.2	●	●	○				●	●	○													
	WNMG080404-DM	8.7	12.7	4.76	5.16	0.4	●	●	●					●	○													
	WNMG080408-DM	8.7	12.7	4.76	5.16	0.8	●	●	●				○	●	○													
	WNMG080412-DM	8.7	12.7	4.76	5.16	1.2	●	●	●				○	●	○													
EM  Medium Cut / Mittl. Bearb.	WNMG06T304-EM	6.5	9.525	3.97	3.81	0.4																						
	WNMG06T308-EM	6.5	9.525	3.97	3.81	0.8																						
	WNMG06T312-EM	6.5	9.525	3.97	3.81	1.2																						
	WNMG060404-EM	6.5	9.525	4.76	3.81	0.4					●				○													
	WNMG060408-EM	6.5	9.525	4.76	3.81	0.8					●				●													
	WNMG080404-EM	8.7	12.7	4.76	5.16	0.4					●	●		●	●													
	WNMG080408-EM	8.7	12.7	4.76	5.16	0.8					●	●		●	●	●												
	WNMG080412-EM	8.7	12.7	4.76	5.16	1.2					●	○																

Tool holder / Klemmhalter



Page/Seite A169

A183

A223



● Ex Stock / ab Lager ○ On demand / auf Anfrage

WN** Negative Insert · Negative WSP

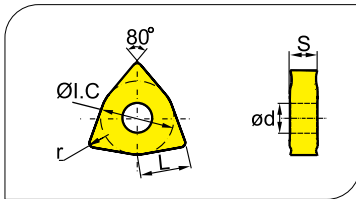
● Ideal Machining Condition / Gute Bearbeitungsbedingungen
 ● Normal Machining Condition / Normale Bearbeitungsbedingungen
 ● Unfavorable Machining Condition / Ungünstige Bearbeitungsbedingungen



Workpiece Material / Werkstoffe	P	M	K	N	S
Steel / Stahl	●●●●●●●●●●	●●●●●●●●●●	●●●●●●●●●●	●●●●●●●●●●	●●●●●●●●●●
Stainless Steel / Rostfreier Stahl	●●●●●●●●●●	●●●●●●●●●●	●●●●●●●●●●	●●●●●●●●●●	●●●●●●●●●●
Cast iron / Gusseisen	●●●●●●●●●●	●●●●●●●●●●	●●●●●●●●●●	●●●●●●●●●●	●●●●●●●●●●
Non-ferrite material / Ne Metalle	●●●●●●●●●●	●●●●●●●●●●	●●●●●●●●●●	●●●●●●●●●●	●●●●●●●●●●
Heat-resistant steel / Warmfester Stahl	●●●●●●●●●●	●●●●●●●●●●	●●●●●●●●●●	●●●●●●●●●●	●●●●●●●●●●

Insert Shape / Schneidplattenform	Type · Typ	Dimension (mm) / Abmessung					Coated Carbide / Beschichtetes Hartmetall										Cermet unbeschichtet	Cermet Coated / Beschicht. Cermet	Uncoated Carbide / unbeschicht. Hartmetall										
		L	I.C	S	d	r	YBC151	YBC251	YBC351	YBG102	YBG202	YBG205	YBG302	YBM151	YBM251	YBM351			YBD052	YBD102	YBD151	YBD152	YBD252	YNG151	YNG151C	YC10	YC40	YD051	YD101
	WNMG080408-NM	8.7	12.7	4.76	5.16	0.8				●	○																		
	WNMG080412-NM	8.7	12.7	4.76	5.16	1.2				●	○																		
Medium Cut / Mittl. Bearb.																													
	DR	WNMG060408-DR	6.5	9.525	4.76	3.81	0.8	●	●	○								●		●									
		WNMG060412-DR	6.5	9.525	4.76	3.81	1.2	●	●	○								●		●									
	Roughing / Schruppen	WNMG080408-DR	8.7	12.7	4.76	5.16	0.8	●	●	●									●		●								
		WNMG080412-DR	8.7	12.7	4.76	5.16	1.2	●	●	●									●		●								
WNMG080416-DR		8.7	12.7	4.76	5.16	1.6	●	●										●		○									
	WNMA06T308	6.5	9.525	3.97	3.81	0.8																							
	WNMA060404	6.5	9.525	4.76	3.81	0.4																							
	WNMA060408	6.5	9.525	4.76	3.81	0.8								●				●		●									
	WNMA060412	6.5	9.525	4.76	3.81	1.2																							
	WNMA080404	8.7	12.7	4.76	5.16	0.4									○				○										
	WNMA080408	8.7	12.7	4.76	5.16	0.8									●				●		●								
	WNMA080412	8.7	12.7	4.76	5.16	1.2									●				●		●								
	WNMA080416	8.7	12.7	4.76	5.16	1.6									○				○		○								

Tool holder / Klemmhalter



Page/Seite A169

A183

A223

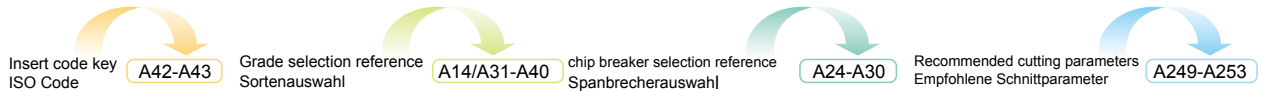

KN** Negative insert/ Negative Inserts

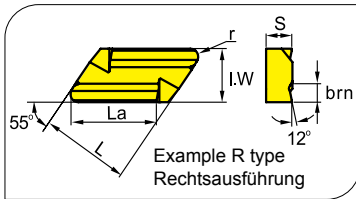

Workpiece Material Werkstoff	Ideal Machining Condition Gute Bearbeitungsbedingungen			Normal Machining Condition Normale Bearbeitungsbedingungen			Unfavorable Machining Condition Ungünstige Bearbeitungsbedingungen			
	P	M	K	N	S	P	M	K	N	S
P Steel / Stahl	●	●	●	●	●	●	●	●	●	●
M Stainless Steel / Rostfreier Stahl	●	●	●	●	●	●	●	●	●	●
K Cast iron / Gusseisen	●	●	●	●	●	●	●	●	●	●
N Non-ferrite material / Ne Metalle	●	●	●	●	●	●	●	●	●	●
S Heat-resistant steel / Warmfester Stahl	●	●	●	●	●	●	●	●	●	●

Insert Shape Schneidplattenform	Type · Typ	Dimension (mm) Abmessung						Coated Carbide Beschichtetes Hartmetall										Cermet unbeschichtet	Cermet Coating beschicht. Cermet	Uncoated Carbide unbeschicht. Hartmetall								
		La	L	I.W	S	brn	r	YBC151	YBC251	YBC351	YBG102	YBG202	YBG205	YBG302	YBM151	YBM251	YBM351			YBD052	YBD102	YBD151	YBD152	YBD252	YNG151	YNG151C	YC10	YC40
 Finishing/ Schichten	KNUX160405L11	16	16.15	9.525	4.76	2.2	0.5	●	●	●																		
	KNUX160410L11	16	16.15	9.525	4.76	2.2	1.0	●	●						●											●		
	KNUX160405L12	16	16.15	9.525	4.76	2.2	0.5	●	●						●											○		
	KNUX160410L12	16	16.15	9.525	4.76	2.2	1.0	●	●						●											○		○
	KNUX160405R11	16	16.15	9.525	4.76	2.2	0.5	●	●	●					●	●										●		●
	KNUX160410R11	16	16.15	9.525	4.76	2.2	1.0	●	●						●											●		
	KNUX160405R12	16	16.15	9.525	4.76	2.2	0.5	●	●						●													
	KNUX160410R12	16	16.15	9.525	4.76	2.2	0.5	●	●						●													

Tool holder / Klemmhalter



Page/Seite A203

A203

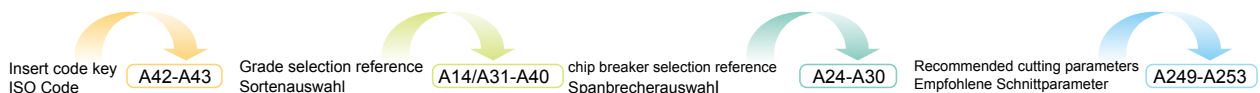

TN** Negative Insert/ Negative WSP

● Ideal Machining Condition / Gute Bearbeitungsbedingungen
● Normal Machining Condition / Normale Bearbeitungsbedingungen
● Unfavorable Machining Condition / Ungünstige Bearbeitungsbedingungen

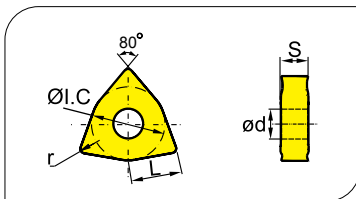

Workpiece Material / Werkstoffe	P	M	K	N	S
Steel / Stahl	●●●●●				
Stainless Steel / Rostfreier Stahl		●●●●●			
Cast iron / Gusseisen			●●●●●		
Non-ferrite material / Ne Metalle				●●●●●	
Heat-resistant steel / Warmfester Stahl					●●●●●

Insert Shape / Schneidplattenform	Type · Typ	Dimension (mm) / Abmessung					Coated Carbide / Beschichtetes Hartmetall										Cermet unbeschichtet	Cermet Coated / Beschicht. Cermet	Uncoated Carbide / unbeschicht. Hartmetall										
		L	I.C	S	d	r	YBC151	YBC251	YBC351	YBG102	YBG202	YBG205	YBG302	YBM151	YBM251	YBM351			YBD052	YBD102	YBD151	YBD152	YBD252	YNG151	YNG151C	YC10	YC40	YD051	YD101
	TNMX1106-2	11.3	15.875	6.35	6.35	1.6	○	●																					
	TNMX1509-2	15.9	22.225	9.52	7.94	1.6																			○		○		
	TNMX15T916-2	15.9	22.225	9.72	7.94	1.6		○																					

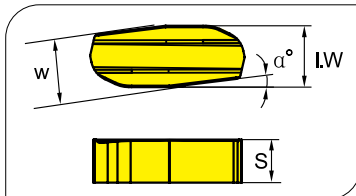

Workpiece Material / Werkstoffe	P	M	K	N	S
Steel / Stahl	●●●●●				
Stainless Steel / Rostfreier Stahl		●●●●●			
Cast iron / Gusseisen			●●●●●		
Non-ferrite material / Ne Metalle				●●●●●	
Heat-resistant steel / Warmfester Stahl					●●●●●

Insert Shape / Schneidplattenform	Type · Typ	Dimension (mm) / Abmessung					Coated Carbide / Beschichtetes Hartmetall										Cermet	Coated Beschicht.	Uncoated Carbide / unbeschicht. Hartmetall										
		L	I.C	S	d	r	YBC151	YBC251	YBC351	YBG102	YBG202	YBG205	YBG302	YBM151	YBM251	YBM351			YBD052	YBD102	YBD151	YBD152	YBD252	YNG151	YNG151C	YC10	YC40	YD051	YD101
	YNMX1812L	18	22	12	20°																								
	YNMX2518173L	25	25	18	7°																								
	YNMX1812150L	18	18	12	15°																								

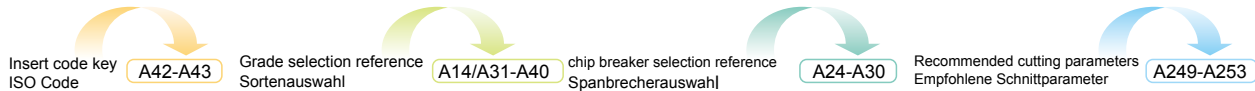

Turning · Drehen

Cemented carbide and cermet Inserts · Hartmetall und Cermet WSP

CP** Positive Insert/ Positive WSP

● Ideal Machining Condition / Gute Bearbeitungsbedingungen
⊗ Normal Machining Condition / Normale Bearbeitungsbedingungen
⊗ Unfavorable Machining Condition / Ungünstige Bearbeitungsbedingungen

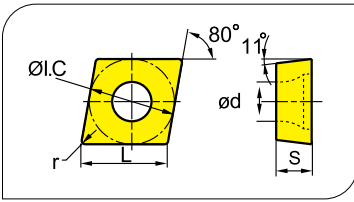

Workpiece Material / Werkstoffe	P	M	K	N	S
Steel / Stahl	●	●	●	●	●
Stainless Steel / Rostfreier Stahl	●	●	●	●	●
Cast iron / Gusseisen	●	●	●	●	●
Non-ferrite material / Ne Metalle	●	●	●	●	●
Heat-resistant steel / Warmfester Stahl	●	●	●	●	●

Insert Shape / Schneidplattenform	Type · Typ	Dimension (mm) / Abmessung					Coated Carbide / Beschichtetes Hartmetall										Cermet unbeschichtet	Cermet Coated / beschicht. Cermet	Uncoated Carbide / unbeschicht. Hartmetall										
		L	I.C	S	d	r	YBC151	YBC251	YBC351	YBG102	YBG202	YBG205	YBG302	YBM151	YBM251	YBM351			YBD052	YBD102	YBD151	YBD152	YBD252	YNG151	YNG151C	YC10	YC40	YD051	YD101
 SF Finishing Schlichten	CPGT060202-SF	6.4	6.35	2.38	2.8	0.2																●	●						
	CPGT060204-SF	6.4	6.35	2.38	2.8	0.4																●	●						
	CPGT09T304-SF	9.7	9.525	3.97	4.4	0.4																	●	●					
 Flat	CPGW060204	6.4	6.35	2.38	2.8	0.4																				●			

Tool holder / Klemmhalter



Page/Seite A235

Insert code key / ISO Code

A42-A43

Grade selection reference / Sortenauswahl

A14/A31-A40

chip breaker selection reference / Spanbrecherauswahl

A24-A30

Recommended cutting parameters / Empfohlene Schnittparameter

A249-A253

Turning · Drehen

Cemented carbide and cermet Inserts · Hartmetall und Cermet WSP

A

RC** Positive Insert/ Positive WSP

● Ideal Machining Condition / Gute Bearbeitungsbedingungen
⊗ Normal Machining Condition / Normale Bearbeitungsbedingungen
⊙ Unfavorable Machining Condition / Ungünstige Bearbeitungsbedingungen

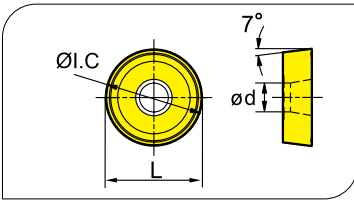

Workpiece Material / Werkstoffe	P	M	K	N	S
Steel / Stahl	●	●	●	●	●
Stainless Steel / Rostfreier Stahl	●	●	●	●	●
Cast iron / Gusseisen	●	●	●	●	●
Non-ferite material / Ne Metalle	●	●	●	●	●
Heat-resistant steel / Warmfester Stahl	●	●	●	●	●

Insert Shape / Schneidplattenform	Type · Typ	Dimension (mm) / Abmessung					Coated Carbide / Beschichtetes Hartmetall										Cermet unbeschichtet	Cermet Coated beschicht. Cem.	Uncoated Carbide / unbeschicht. Hartmetall									
		L	I.C	S	d	r	YBC151	YBC251	YBC351	YBG102	YBG202	YBG205	YBG302	YBM151	YBM251	YBM351			YBD052	YBD102	YBD151	YBD152	YBD252	YNG151	YNG151C	YC10	YC40	YD051
 Light roughing / Leicht Schruppen	RCMX0803MO	8.0	8.0	3.18	3.36	\	○	●	○																			
	RCMX1003MO	10	10	3.18	3.6	\	●	●	●																			
	RCMX1204MO	12	12	4.76	4.4	\	●	●	●																○			
	RCMX1606MO	16	16	6.35	5.5	\	●	●	●										○						○			
	RCMX2006MO	20	20	6.35	6.5	\	●	●	●					●						●						○	○	
	RCMX2507MO	25	25	7.94	7.2	\	○	●	●																			
	RCMX3209MO	32	32	9.52	9.5	\	○	●	●											○								
	RCMX3209MO-PV	32	32	9.52	9.5	\		●																				

Tool holder / Klemmhalter



Page/Seite A202

General Turning · Allgemeine Drehbearbeitung

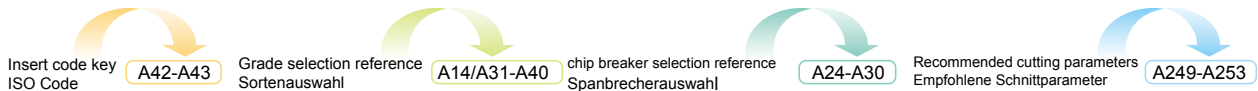

Turning · Drehen

Cemented carbide and cermet Inserts · Hartmetall und Cermet WSP

A

General Turning · Allgemeine Drehbearbeitung

TC** Positive Insert/ Positive WSP

● Ideal Machining Condition / Gute Bearbeitungsbedingungen
 ● Normal Machining Condition / Normale Bearbeitungsbedingungen
 ● Unfavorable Machining Condition / Ungünstige Bearbeitungsbedingungen

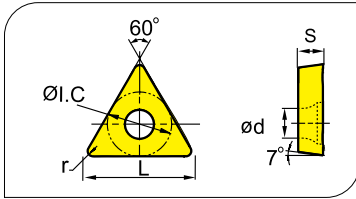

Workpiece Material / Werkstoffe	P	M	K	N	S
Steel / Stahl	●	●	●	●	●
Stainless Steel / Rostfreier Stahl	●	●	●	●	●
Cast iron / Gusseisen	●	●	●	●	●
Non-ferrous material / Nf Metalle	●	●	●	●	●
Heat-resistant steel / Warmfester Stahl	●	●	●	●	●

Insert Shape / Schneidplattenform	Type · Typ	Dimension (mm) / Abmessung					Coated Carbide / Beschichtetes Hartmetall										Cermet unbeschichtet	Cermet Coated / beschicht. Cermet	Uncoated Carbide unbeschicht. Hartmetall									
		L	I.C	S	d	r	YBC151	YBC251	YBC351	YBG102	YBG202	YBG205	YBG302	YBM151	YBM251	YBM351			YBD052	YBD102	YBD151	YBD152	YBD252	YNG151	YNG151C	YC10	YC40	YD051
 Finishing / Schlichten	TCGT06T102-SF	6.4	3.97	1.98	2.2	0.2																○	●					
	TCGT06T104-SF	6.4	3.97	1.98	2.2	0.4																						
	TCGT090202-SF	9.6	5.56	2.38	2.5	0.2																●	●					
	TCGT090204-SF	9.6	5.56	2.38	2.5	0.4																●	●					
	TCGT090208-SF	9.6	5.56	2.38	2.5	0.8																	●					
	TCGT110302-SF	11	6.35	3.18	2.8	0.2																	●					
	TCGT110304-SF	11	6.35	3.18	2.8	0.4																●	●					
	TCGT110308-SF	11	6.35	3.18	2.8	0.8																	●					

Tool holder / Klemmhalter



Page/Seite A197

A197

A198

A199

A230

● Ex Stock / ab Lager ○ On demand / auf Anfrage

TC** Positive Insert/ Positive WSP

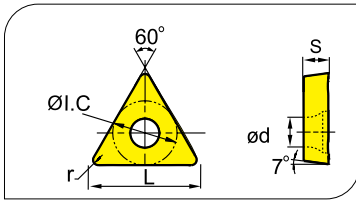

Workpiece Material / Werkstoffe	Ideal Machining Condition / Gute Bearbeitungsbedingungen			Normal Machining Condition / Normale Bearbeitungsbedingungen			Unfavorable Machining Condition / Ungünstige Bearbeitungsbedingungen		
	P	M	K	N	S				
P Steel / Stahl	●	●	●	●	●	●	●	●	●
M Stainless Steel / Rostfreier Stahl		●	●	●	●	●	●	●	●
K Cast iron / Gusseisen						●	●	●	●
N Non-ferrite material / Ne Metalle				●					●
S Heat-resistant steel / Warmfester Stahl				●	●				●

Insert Shape / Schneidplattenform	Type · Typ	Dimension (mm) / Abmessung					Coated Carbide / Beschichtetes Hartmetall										Cermet unbeschichtet	Cermet Coated / Beschicht. Cermet	Uncoated Carbide unbeschicht. Hartmetall									
		L	I.C	S	d	r	YBC151	YBC251	YBC351	YBG102	YBG202	YBG205	YBG302	YBM151	YBM251	YBM351			YBD052	YBD102	YBD151	YBD152	YBD252	YNG151	YNG151C	YC10	YC40	YD051
HF Finishing / Schlichten	TCMT06T104-HF	6.4	3.97	1.98	2.2	0.4																						
	TCMT06T108-HF	6.4	3.97	1.98	2.2	0.8																						
	TCMT090202-HF	9.6	5.56	2.38	2.5	0.2		●														●						
	TCMT090204-HF	9.6	5.56	2.38	2.5	0.4		●						●								●						
	TCMT090208-HF	9.6	5.56	2.38	2.5	0.8		○	●													●						
	TCMT110202-HF	11	6.35	2.38	2.8	0.2			●		●																	
	TCMT110204-HF	11	6.35	2.38	2.8	0.4		●	●	○												●	●					
	TCMT110208-HF	11	6.35	2.38	2.8	0.8		●		○					●							●						
	TCMT16T302-HF	16.5	9.525	3.97	4.4	0.2																						
	TCMT16T304-HF	16.5	9.525	3.97	4.4	0.4		●	●		●		○									●						
	TCMT16T308-HF	16.5	9.525	3.97	4.4	0.8		●	●													●						

Tool holder / Klemmhalter



Page/Seite A197 A197 A198 A199 A230

Insert code key / ISO Code

A42-A43

Grade selection reference / Sortenauswahl

A14/A31-A40

chip breaker selection reference / Spanbrecherauswahl

A24-A30

Recommended cutting parameters / Empfohlene Schnittparameter

A249-A253

Turning · Drehen

Cemented carbide and cermet Inserts · Hartmetall und Cermet WSP

VC** Positive Insert/ Positive WSP

● Ideal Machining Condition / Gute Bearbeitungsbedingungen
 ● Normal Machining Condition / Normale Bearbeitungsbedingungen
 ● Unfavorable Machining Condition / Ungünstige Bearbeitungsbedingungen

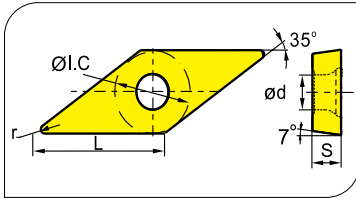

Workpiece Material / Werkstoffe	P	M	K	N	S
Steel / Stahl	●	●	●	●	●
Stainless Steel / Rostfreier Stahl	●	●	●	●	●
Cast iron / Gusseisen	●	●	●	●	●
Non-ferrite material / Ne Metalle	●	●	●	●	●
Heat-resistant steel / Warmfester Stahl	●	●	●	●	●

Insert Shape / Schneidplattenform	Type · Typ	Dimension (mm) / Abmessung					Coated Carbide / Beschichtetes Hartmetall										Cermet unbeschichtet	Cermet Coated / beschicht. Cermet	Uncoated Carbide / unbeschicht. Hartmetall								
		L	I.C	S	d	r	YBC151	YBC251	YBC351	YBG102	YBG202	YBG205	YBG302	YBM151	YBM251	YBM351			YBD052	YBD102	YBD151	YBD152	YBD252	YNG151	YNG151C	YC10	YC40
SF Finishing Schlichten	VCGT110302-SF	11	6.35	3.18	2.8	0.2																●	●				
	VCGT110304-SF	11	6.35	3.18	2.8	0.4																●	●				
	VCGT160404-SF	16.5	9.525	4.8	4.4	0.4																	○				
HF Finishing Schlichten	VCGT110304-HF	11	6.35	3.18	2.8	0.4	●																				
	VCGT130304	13.8	7.94	3.3	3.4	0.4	●																				
NF Finishing Schlichten	VCGT160408-NF	16.5	9.525	4.76	4.4	0.8																					

Tool holder / Klemmhalter



Page/Seite A231

A232

A193

A194

● Ex Stock / ab Lager ○ On demand / auf Anfrage

Turning · Drehen

Cemented carbide and cermet Inserts · Hartmetall und Cermet WSP

A

VB** Positive Insert/ Positive WSP

● Ideal Machining Condition / Gute Bearbeitungsbedingungen
 ● Normal Machining Condition / Normale Bearbeitungsbedingungen
 ● Unfavorable Machining Condition / Ungünstige Bearbeitungsbedingungen

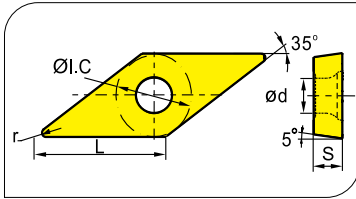

Workpiece Material / Werkstoffe	P	M	K	N	S
Steel / Stahl	●	●	●	●	●
Stainless Steel / Rostfreier Stahl	●	●	●	●	●
Cast iron / Gusseisen	●	●	●	●	●
Non-ferrite material / Ne Metalle	●	●	●	●	●
Heat-resistant steel / Warmfester Stahl	●	●	●	●	●

Insert Shape / Schneidplattenform	Type · Typ	Dimension (mm) / Abmessung					Coated Carbide / Beschichtetes Hartmetall										Cermet unbeschichtet	Cermet Coated / beschicht. Cermet	Uncoated Carbide / unbeschicht. Hartmetall										
		L	I.C	S	d	r	YBC151	YBC251	YBC351	YBG102	YBG202	YBG205	YBG302	YBM151	YBM251	YBM351			YBD052	YBD102	YBD151	YBD152	YBD252	YNG151	YNG151C	YC10	YC40	YD051	YD101
SF Finishing Schlichten	VBGT110302-SF	11	6.35	3.18	2.8	0.2																							
	VBGT110304-SF	11	6.35	3.18	2.8	0.4																							
EF Finishing Schlichten	VBMT110302-EF	11	6.35	3.18	2.8	0.2																							
	VBMT110304-EF	11	6.35	3.18	2.8	0.4																							
	VBMT110308-EF	11	6.35	3.18	2.8	0.8																							
	VBMT160404-EF	16.5	9.525	4.76	4.4	0.4																							
	VBMT160408-EF	16.5	9.525	4.76	4.4	0.8																							
53 Finishing Schlichten	VBMT160404-53	16.6	9.525	4.76	4.4	0.4	●	●	○	●												●	○						
	VBMT160408-53	16.6	9.525	4.76	4.4	0.4	●	●	○	●												●	○						
HF Finishing Schlichten	VBMT110202-HF	11	6.35	2.38	2.8	0.2		●	○	●																			
	VBMT110204-HF	11	6.35	2.38	2.8	0.4		●		●		●										●							
	VBMT110208-HF	11	6.35	2.38	2.8	0.8		●	●		●													○					
NF Finishing Schlichten	VBET160404-NF	16.5	9.525	4.76	4.4	0.4																							
	VBET160408-NF	16.5	9.525	4.76	4.4	0.8																							

Tool holder / Klemmhalter



Page/Seite A190 A191 A192 A233 A234

● Ex Stock / ab Lager ○ On demand / auf Anfrage

WC** Positive Insert/ Positive WSP

● Ideal Machining Condition / Gute Bearbeitungsbedingungen
⊗ Normal Machining Condition / Normale Bearbeitungsbedingungen
⊗ Unfavorable Machining Condition / Ungünstige Bearbeitungsbedingungen

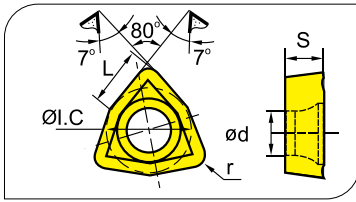

Workpiece Material / Werkstoffe	P	M	K	N	S
P Steel / Stahl	●	●	●	●	●
M Stainless Steel / Rostfreier Stahl	●	●	●	●	●
K Cast iron / Gusseisen	●	●	●	●	●
N Non-ferite material / Ne Metalle	●	●	●	●	●
S Heat-resistant steel / Warmfester Stahl	●	●	●	●	●

insert shape Schneidplattenform	Type · Typ	Dimension (mm) Abmessung					Coated Carbide Beschichtete Hartmetall										Cermet unbeschichtet	Cermet Coated beschicht. Cermet	carbide Hartmetall									
		L	I.C	S	d	r	YBC151	YBC251	YBC351	YBG102	YBG202	YBG205	YBG302	YBM151	YBM251	YBM351			YBD052	YBD102	YBD151	YBD152	YBD252	YNG151	YNG151C	YC10	YC40	YD051
	WCMX040208R-53	4.3	6.35	2.38	3.1	0.8																						
	WCMX06T308R-53	6.5	9.525	3.97	3.7	0.8																						
	WCMX080412R-53	8.7	12.7	4.76	4.3	1.2																						

Tool holder / Klemmhalter





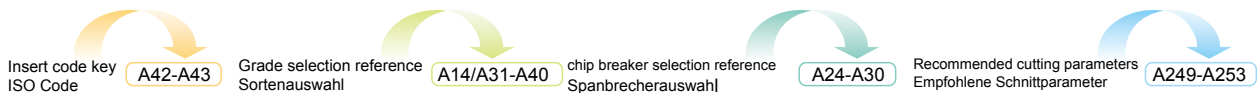











Page/Seite A200









Turning · Drehen

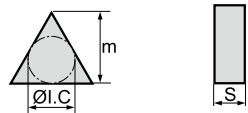

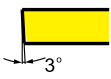
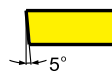
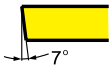
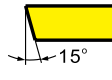

PCBN & PCD Inserts Code Key · PCBN & PCD ISO Kennzeichnung WSP

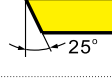
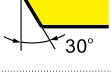
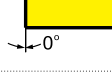
Insert shape / Schneidplattenform		
 A	 B	 C
 D	 E	 H
 K	 L	 M
 P	 S	 T
 V	 W	Others Z

Tolerance / Toleranzklasse							
							
Code	Tolerance Toleranzklasse	Tolerance ØI.C	Thickness S Dicke	Code	Tolerance	Tolerance ØI.C	Thickness S Dicke
A	±0.005	±0.025	±0.025	J	±0.005	±0.05-±0.13	±0.025
F	±0.005	±0.013	±0.025	K	±0.013	±0.05-±0.13	±0.025
C	±0.013	±0.025	±0.025	L	±0.025	±0.05-±0.13	±0.025
H	±0.013	±0.013	±0.025	M	±0.08-±0.18	±0.05-±0.13	±0.13
E	±0.025	±0.025	±0.025	N	±0.08-±0.18	±0.05-±0.13	±0.025
G	±0.025	±0.025	±0.13	U	±0.13-±0.38	±0.08-±0.25	±0.13

C N G A

Clearance angle of main cutting edge Freiwinkel der Hauptschneide			
Code	Angle / Winkel	Code	Angle / Winkel
A	 3°	B	 5°
C	 7°	D	 15°
E	 20°	F	 25°
G	 30°	N	 0°
P	 11°	O	Others

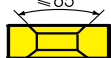
Insert type / Plattentyp		
Code	Hole	Insert Section
N	---	
B	✓	
C	✓	
A	✓	
W	✓	
Q	✓	
X	---	Special

Cutting edge length / Schneidenlänge (mm)		Insert Shape/ Plattenform					
Ø.I.C (mm)	C	D	S	T	V	W	
3.97				06			
5.0				09			
5.56							
6.0							
6.35	06	07		11	11		
8.0							
9.525	09	11	09	16	16	06	
10.0							
12.0							
12.7	12	15	12	22	22	08	
15.875	16		15	27			
16.0		19					
19.05	19		19	33			
20.0							
25.0	25	25					
25.4			25				
31.75							
32							

Insert thickness / Dicke (mm)			
Code	Insert Thickness / Dicke	Code	Insert Thickness / Dicke
02	2.38	06	6.35
T2	2.58	T6	6.75
03	3.18	07	7.94
T3	3.97	09	9.52
04	4.76	T9	9.72
T4	4.96	11	11.11
05	5.56	12	12.70
T5	5.95		

Nose radius Eckenradius	
Code	Radius (mm)
00	-
02	0.2
04	0.4
08	0.8
12	1.2
16	1.6
20	2.0
24	2.4
32	3.2
X	Others Andere
Mo	Round Insert Runde Platten

12 04 08 T 3 1 -2 W

Profile of cutting edges Schneidkantenausführung		
Code	Cutting Edge Schneidkante	Shape Form Plattenform
F	Sharp edges Scharfe Kante	
E	Honing Verrundung	
T	Chamfering Fase	
S	Chamfering Fase + Honing Verrundung	







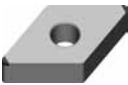

Angle of Chamfer Winkel der Fase	
Code	Angle
0	5°
1	10°
2	15°
3	20°
4	25°
5	30°

Width of Chamfer Breite der Fase	
Code	Width
0	0.1
1	0.15
2	0.2
3	0.25
4	0.3
5	0.35
6	0.4
7	0.45





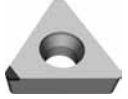



Number of cutting edges Anzahl der Schneidkanten		
Code	Number of edges Anzahl der Schneidkanten	Diagram
1	1	
2	2	
3	3	
4	4	

Wiper edge Wiperfase
W

PCBN

	Insert Shape Schneidplattenform	Type · Typ	Grade · Sorte				
			YCB111	YCB121	YCB131	YCB211	
Negative Inserts · WSP	 A118	CNGA120404-2	●	●	●	○	
		CNGA120408-2	●	●	●	●	
		CNGA120412-2	●	●	●	●	
		CNGA120408-2W	●	●			
		CNGA120412-2W	●	●			
	 A119	DNGA150604-2	●	●		○	
		DNGA150608-2	●	●	○	●	
		DNGA150612-2	●	●	○	○	
	 A120	SNGA120408-2	○	●	●	○	
		SNGA120412-2	○	●	●	○	
	 A121	TNGA160404-3	●	●			
		TNGA160408-3	●	●	●	●	
		TNGA160412-3	●	●	●	●	
	 A122	VNGA160404-2	●	○			
		VNGA160408-2	●	○			
	 A122	WNGA160404-3		●			
		WNGA160408-3		●			
	Positive Inserts · WSP	 A123	CCGW060204-1	●	●		
			CCGW060208-1	●	●		
			CCGW09T304-2	●	●	○	●
CCGW09T308-2			●	●	○	●	
CCGW120404-2			○	●	○	●	
CCGW120408-2			○	●	○	●	
 A124		DCGW070202-1	○	○			
		DCGW070204-1	●	●			
		DCGW070208-1	●	●			
		DCGW11T304-2	●	●	○	●	
		DCGW11T308-2	●	●	○	●	
 A125		TCGW110204-1	●	●	○		
		TCGW110208-1	●	●	○		
		TCGW16T304-3	●	●	○	○	
		TCGW16T308-3	●	●	○	○	
 A126		VBGW160404-2	●	●		●	
		VBGW160408-2	●	●		●	
 A126		VCGW160404-2	●	●		●	
		VCGW160408-2	●	●		●	

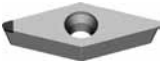
PCD

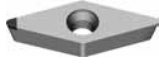
Insert Shape Schneidplattenform	Type · Typ	Grade · Sorte
		YCD421
 A127	CCMT060202	•
	CCMT060204	•
	CCMT09T304	•
	CCMT09T308	•
	CCMT120404	•
	CCMT120408	•
 A128	CCMW060202	•
	CCMW060204	•
	CCMW09T304	•
	CCMW09T308	•
	CCMW120404	•
	CCMW120408	•
 A129	DCMT070202	•
	DCMT070204	•
	DCMT11T302	•
	DCMT11T304	•
	DCMT11T308	•
 A130	DCMW070202	•
	DCMW070204	•
	DCMW070208	•
	DCMW11T302	•
	DCMW11T304	•
	DCMW11T308	•
 A131	TCMT110204	•
	TCMT16T304	•
	TCMT16T308	•
 A132	TCMW110208	•
	TCMW160304	•
	TCMW160308	•
 A133	VBMT160404	•
	VBMT160408	•
 A133	VBMW160404	•
	VBMW160408	•
 A134	VCMT160404	•
	VCMT160408	•
 A134	VCMW160404	•
	VCMW160408	•

Turning · Drehen

PCBN & PCG Inserts · PCBN & PCG WSP

CN**

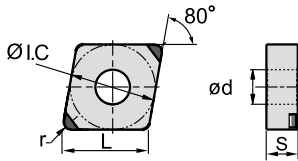

● Continuous cutting
Vollschnitt

● Continuous and interrupted cutting
Voll- und leicht unterbrochener Schnitt

● Interrupted cutting
Stark unterbrochener Schnitt

Workpiece Material Werkstoffe	H	Hardened material / Gehärtete Werkstoff	●	●	●				
	K	Cast iron / Gussseisen							●
	N	Non-ferrite material / Nf Metalle							

Insert Shape Schneid- plattenform	Type · Typ	Dimension (mm) Abmessung					CBN			
		L	I.C	S	d	r	YCB111	YCB121	YCB131	YCB211
	CNGA120404-2	12.9	12.7	4.76	5.16	0.4	●	●	●	○
	CNGA120408-2	12.9	12.7	4.76	5.16	0.8	●	●	●	●
	CNGA120412-2	12.9	12.7	4.76	5.16	1.2	●	●	●	●
	CNGA120408-2W	12.9	12.7	4.76	5.16	0.8	●	●		
	CNGA120412-2W	12.9	12.7	4.76	5.16	1.2	●	●		

Tool Holder · Klemmhalter

PCLNR/L

Kr:95°



MCLNR/L

Kr:95°



PCLNR/L

Kr:95°



Page -Seite A159

A171

A216

● Ex Stock / ab Lager ○ On demand / auf Anfrage

DN**

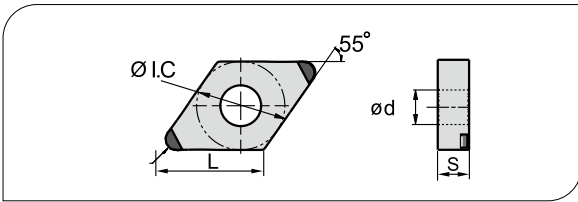

- Continuous cutting
Vollschnitt
- ⊗ Continuous and interrupted cutting
Voll- und leicht unterbrochener Schnitt
- ⊙ Interrupted cutting
Stark unterbrochener Schnitt

Workpiece Material Werkstoffe	H	Hardened material / Gehärtete Werkstoff	●	⊗	⊙					
	K	Cast iron / Guss Eisen							●	
	N	Non-ferrous material / Nichte Metalle								

Insert Shape Schneid- plattenform	Type · Typ	Dimension (mm) Abmessung					CBN			
		L	I.C	S	d	r	YCB111	YCB121	YCB131	YCB211
	DNGA150604-2	15.5	12.7	6.35	5.16	0.4	●	●	●	○
	DNGA150608-2	15.5	12.7	6.35	5.16	0.8	●	●	○	●
	DNGA150612-2	15.5	12.7	6.35	5.16	1.2	●	●	○	○

General Turning · Allgemeine Drehbearbeitung

Tool Holder · Klemmhalter



Page · Seite A160

A161

A172

A173

A218

A219

● Ex Stock / ab Lager ○ On demand / auf Anfrage

Turning · Drehen

PCBN & PCG Inserts · PCBN & PCG WSP

SN**

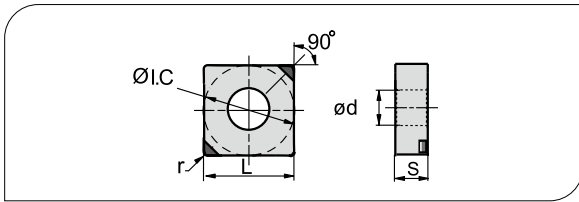

● Continuous cutting
Vollschnitt

⊗ Continuous and interrupted cutting
Voll- und leicht unterbrochener Schnitt

⊛ Interrupted cutting
Stark unterbrochener Schnitt

Workpiece Material Werkstoffe	H	Hardened material / Gehärtete Werkstoff	○	⊗	⊛					
	K	Cast iron / Gusseisen							●	
	N	Non-ferrite material / Ne Metalle								

Insert Shape Schneid- plattenform	Type · Typ	Dimension (mm) Abmessung					CBN			
		L	I.C	S	d	r	YCB111	YCB121	YCB131	YCB211
	SNGA120408-2	12.7	12.7	4.76	5.16	0.8	○	●	○	○
	SNGA120412-2	12.7	12.7	4.76	5.16	1.2	○	●	○	○

Tool Holder · Klemmhalter

PSBNR/L Kr:75° 	PSDNN Kr:45° 	PSKNR/L Kr:75° 	PSSNR/L Kr:45° 	MSBNR/L Kr:75° 	MSRNR/L Kr:75° 	MSKNR/L Kr:75°
Page · Seite A162	A163	A164	A165	A162	A175	A176
MSDNN Kr:45° 	PSKNR/L Kr:75° 					
Page · Seite A177	A221					

● Ex Stock / ab Lager ○ On demand / auf Anfrage

TN**

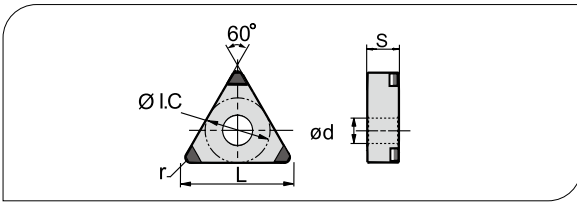

- Continuous cutting
Vollschnitt
- ⊗ Continuous and interrupted cutting
Voll- und leicht unterbrochener Schnitt
- ⊗ Interrupted cutting
Stark unterbrochener Schnitt

Workpiece Material Werkstoffe	H	Hardened material / Gehärtete Werkstoff	●	⊗	⊗						
	K	Cast iron / Gusseisen							●		
	N	Non-ferrous material / Nichte Metalle									

Insert Shape Schneid- plattenform	Type · Typ	Dimension (mm) Abmessung					CBN				
		L	I.C	S	d	r	YCB111	YCB121	YCB131	YCB211	
	TNGA160404-3	16.5	9.525	4.76	3.81	0.4	●	●			
	TNGA160408-3	16.5	9.525	4.76	3.81	0.8	●	●	●	●	
	TNGA160412-3	16.5	9.525	4.76	3.81	1.2	●	●	●	●	

Tool Holder · Klemmhalter



Page · Seite A166

A167

A168

A178

A179

A180

A222

● Ex Stock / ab Lager ○ On demand / auf Anfrage

Turning · Drehen

PCBN & PCG Inserts · PCBN & PCG WSP

VN**

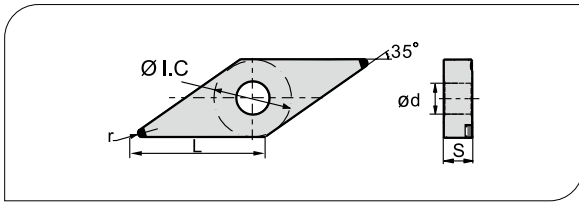

● Continuous cutting
Vollschnitt

⊗ Continuous and interrupted cutting
Voll- und leicht unterbrochener Schnitt

⊗ Interrupted cutting
Stark unterbrochener Schnitt

Workpiece Material Werkstoffe	Workpiece Material / Gehärtete Werkstoff				Workpiece Material / Gusseisen				Workpiece Material / Ne Metalle			
	●	⊗	⊗	⊗	●	⊗	⊗	⊗	●	⊗	⊗	⊗
H	●	⊗	⊗	⊗								
K					●	⊗	⊗	⊗	●	⊗	⊗	⊗
N												

Insert Shape Schneid- plattenform	Type · Typ	Dimension (mm) Abmessung					CBN			
		L	I.C	S	d	r	YCB111	YCB121	YCB131	YCB211
	VNGA160404-2	16.6	9.525	4.76	3.81	0.4	●	○		
	VNGA160408-2	16.6	9.525	4.76	3.81	0.8	●	○		

Tool Holder · Klemmhalter



Page · Seite A181

A182

WN**

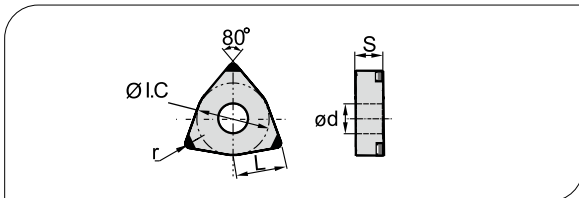

● Continuous cutting
Vollschnitt

⊗ Continuous and interrupted cutting
Voll- und leicht unterbrochener Schnitt

⊗ Interrupted cutting
Stark unterbrochener Schnitt

Workpiece Material Werkstoffe	Workpiece Material / Gehärtete Werkstoff				Workpiece Material / Gusseisen				Workpiece Material / Ne Metalle			
	●	⊗	⊗	⊗	●	⊗	⊗	⊗	●	⊗	⊗	⊗
H	●	⊗	⊗	⊗								
K					●	⊗	⊗	⊗	●	⊗	⊗	⊗
N												

Insert Shape Schneid- plattenform	Type · Typ	Dimension (mm) Abmessung					CBN			
		L	I.C	S	d	r	YCB111	YCB121	YCB131	YCB211
	WNGA080408-3	8.69	12.7	4.76	5.16	0.8		●		
	WNGA160404-3	8.69	12.7	4.76	5.16	0.4		●		
	WNGA160408-3	8.69	12.7	4.76	5.16	0.8		●		

Tool Holder · Klemmhalter



Page · Seite A169

A183

A223

● Ex Stock / ab Lager ○ On demand / auf Anfrage

CC**

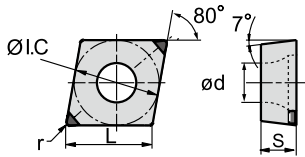

● Continuous cutting
Vollschnitt

● Continuous and interrupted cutting
Voll- und leicht unterbrochener Schnitt

● Interrupted cutting
Stark unterbrochener Schnitt

Workpiece Material Werkstoffe	Workpiece Material / Werkstoffe			
	H Hardened material / Gehärtete Werkstoff	●	●	●
K Cast iron / Gusseisen				●
N Non-ferrous material / Ne Metalle				

Insert Shape Schneidplattenform	Type · Typ	Dimension (mm) Abmessung					CBN			
		L	I.C	S	d	r	YCB111	YCB121	YCB131	YCB211
	CCGW060204-1	6.4	6.35	2.38	2.8	0.4	●	●		
	CCGW060208-1	6.4	6.35	2.38	2.8	0.8	●	●		
	CCGW09T304-2	9.7	9.525	3.97	4.4	0.4	●	●	○	●
	CCGW09T308-2	9.7	9.525	3.97	4.4	0.8	●	●	○	●
	CCGW120404-2	12.9	12.7	4.76	5.5	0.4	○	●	○	●
	CCGW120408-2	12.9	12.7	4.76	5.5	0.8	○	●	○	●

Tool Holder · Klemmhalter



SCACR/L
Kr:90°



SCLCR/L
Kr:95°



SCLCR/L
Kr:95°



SCFCR
Kr:90°



SCLCR
Kr:95°

Page · Seite A185

A186

A224

A239

A240

● Ex Stock / ab Lager ○ On demand / auf Anfrage

Turning · Drehen

PCBN & PCG Inserts · PCBN & PCG WSP

DC**

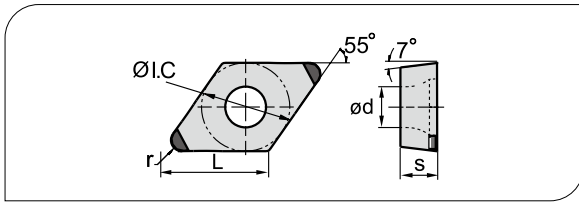

● Continuous cutting
Vollschnitt

⊗ Continuous and interrupted cutting
Voll- und leicht unterbrochener Schnitt

⊛ Interrupted cutting
Stark unterbrochener Schnitt

Workpiece Material Werkstoffe	H	Hardened material / Gehärtete Werkstoff	●	⊗	⊛				
	K	Cast iron / Gusseisen						●	
	N	Non-ferrous material / Nichte Metalle							

Insert Shape Schneid- plattenform	Type · Typ	Dimension (mm) Abmessung					CBN			
		L	I.C	S	d	r	YCB111	YCB121	YCB131	YCB211
	DCGW070204-1	7.8	6.35	2.38	2.8	0.4	●	●		
	DCGW070208-1	7.8	6.35	2.38	2.8	0.8	●	●		
	DCGW11T304-2	11.6	9.525	3.97	4.4	0.4	●	●	○	●
	DCGW11T308-2	11.6	9.525	3.97	4.4	0.8	●	●	○	●

Tool Holder · Klemmhalter

SDACR/L
Kr:90°



Page-Seite A187

SDJCR/L
Kr:93°



A188

SDNCN
Kr:45°



A189

SDQCR/L
Kr:107°30'



A226

SDUCR/L
Kr:93°



A227

SDZCR/L
Kr:85°



A228

● Ex Stock / ab Lager ○ On demand / auf Anfrage

TC**

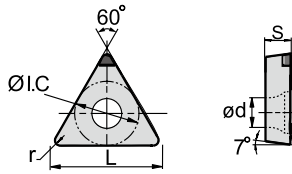

● Continuous cutting
Vollschnitt

⊗ Continuous and interrupted cutting
Voll- und leicht unterbrochener Schnitt

⊗ Interrupted cutting
Stark unterbrochener Schnitt

Workpiece Material Werkstoffe	H	Hardened material / Gehärtete Werkstoff	●	⊗	⊗					
	K	Cast iron / Gusseisen							●	
	N	Non-ferrite material / Nichte Metalle								

Insert Shape Schneid- plattenform	Type · Typ	Dimension (mm) Abmessung					CBN			
		L	I.C	S	d	r	YCB111	YCB121	YCB131	YCB211
	TCGW110204-1	9.6	5.56	2.38	2.5	0.4	●	●	○	
	TCGW110208-1	9.6	5.56	2.38	2.5	0.8	●	●	○	
	TCGW16T304-3	16.5	9.525	3.97	4.4	0.4	●	●	○	○
	TCGW16T308-3	16.5	9.525	3.97	4.4	0.8	●	●	○	○

Tool Holder · Klemmhalter

STACR/L
Kr:90°



STFCR/L
Kr:91°



STGCR/L
Kr:91°



STTCR/L
Kr:60°



STFCR/L
Kr:90°



Page · Seite A197

A197

A198

A199

A230

● Ex Stock / ab Lager ○ On demand / auf Anfrage

Turning · Drehen

PCBN & PCG Inserts · PCBN & PCG WSP

VB**

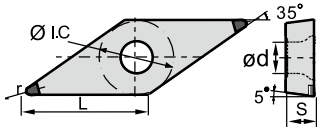

- Continuous cutting
Vollschnitt
- ⊗ Continuous and interrupted cutting
Voll- und leicht unterbrochener Schnitt
- ⊗ Interrupted cutting
Stark unterbrochener Schnitt

Workpiece Material Werkstoffe	H	Hardened material / Gehärtete Werkstoff	<input type="checkbox"/>	<input type="checkbox"/>	<input type="checkbox"/>	<input type="checkbox"/>	<input type="checkbox"/>	<input type="checkbox"/>	<input type="checkbox"/>
	K	Cast iron / Gusseisen	<input type="checkbox"/>	<input type="checkbox"/>	<input type="checkbox"/>	<input type="checkbox"/>	<input type="checkbox"/>	<input checked="" type="checkbox"/>	<input type="checkbox"/>
	N	Non-ferrite material / Nf Metalle	<input type="checkbox"/>	<input type="checkbox"/>	<input type="checkbox"/>	<input type="checkbox"/>	<input type="checkbox"/>	<input type="checkbox"/>	<input type="checkbox"/>

Insert Shape Schneid- plattenform	Type · Typ	Dimension (mm) Abmessung					CBN			
		L	I.C	S	d	r	YCB111	YCB121	YCB131	YCB211
	VBGW160404-2	16.6	9.525	4.76	4.4	0.4	<input checked="" type="checkbox"/>	<input checked="" type="checkbox"/>	<input type="checkbox"/>	<input checked="" type="checkbox"/>
	VBGW160408-2	16.6	9.525	4.76	4.4	0.8	<input checked="" type="checkbox"/>	<input checked="" type="checkbox"/>	<input type="checkbox"/>	<input checked="" type="checkbox"/>

Tool Holder · Klemmhalter

SVJBR/L
Kr:93°



SVABR/L
Kr:90°



SVVBN
Kr:72°30'



SVQBR/L
Kr:107°30'



SVUBR/L
Kr:93°



Page · Seite A190

A191

A192

A233

A234

VC**

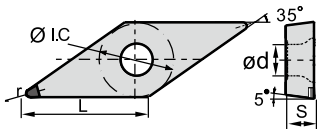

- Continuous cutting
Vollschnitt
- ⊗ Continuous and interrupted cutting
Voll- und leicht unterbrochener Schnitt
- ⊗ Interrupted cutting
Stark unterbrochener Schnitt

Workpiece Material Werkstoffe	H	Hardened material / Gehärtete Werkstoff	<input type="checkbox"/>	<input type="checkbox"/>	<input type="checkbox"/>	<input type="checkbox"/>	<input type="checkbox"/>	<input type="checkbox"/>	<input type="checkbox"/>
	K	Cast iron / Gusseisen	<input type="checkbox"/>	<input type="checkbox"/>	<input type="checkbox"/>	<input type="checkbox"/>	<input type="checkbox"/>	<input checked="" type="checkbox"/>	<input type="checkbox"/>
	N	Non-ferrite material / Nf Metalle	<input type="checkbox"/>	<input type="checkbox"/>	<input type="checkbox"/>	<input type="checkbox"/>	<input type="checkbox"/>	<input type="checkbox"/>	<input type="checkbox"/>

Insert Shape Schneid- plattenform	Type · Typ	Dimension (mm) Abmessung					CBN			
		L	I.C	S	d	r	YCB111	YCB121	YCB131	YCB211
	VCGW160404-2	16.6	9.525	4.76	4.4	0.4	<input checked="" type="checkbox"/>	<input checked="" type="checkbox"/>	<input type="checkbox"/>	<input checked="" type="checkbox"/>
	VCGW160408-2	16.6	9.525	4.76	4.4	0.8	<input checked="" type="checkbox"/>	<input checked="" type="checkbox"/>	<input type="checkbox"/>	<input checked="" type="checkbox"/>

Tool Holder · Klemmhalter

SVQCR/L
Kr:107°30'



SVUCR/L
Kr:93°



SVVCN
Kr:72°30'



SVJCR/L
Kr:93°



Page · Seite A231

A232

A193

A194

● Ex Stock / ab Lager ○ On demand / auf Anfrage

Turning · Drehen

PCBN & PCG Inserts · PCBN & PCG WSP

TC**

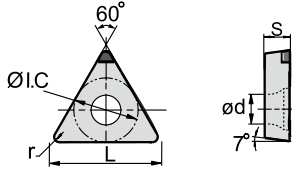

- Continuous cutting
Vollschnitt
- Continuous and interrupted cutting
Voll- und leicht unterbrochener Schnitt
- Interrupted cutting
Stark unterbrochener Schnitt

Workpiece Material Werkstoffe	H	Hardened material / Gehärtete Werkstoff							
	K	Cast iron / Gusseisen							
	N	Non-ferrous material / Nichte Metalle	●						

Insert Shape Schneid- plattenform	Type · Typ	Dimension (mm) Abmessung					PCD				
		L	I.C	S	d	r	YCD421				
	TCMW110208	11	6.35	2.38	2.8	0.8	●				
	TCMW16T304	16.5	9.525	3.97	4.4	0.4	●				
	TCMW16T308	16.5	9.525	3.97	4.4	0.8	●				

Applicable tools



Page A197 A197 A198 A199 A230

● Ex Stock / ab Lager ○ On demand / auf Anfrage

Turning · Drehen

PCBN & PCG Inserts · PCBN & PCG WSP

VC**

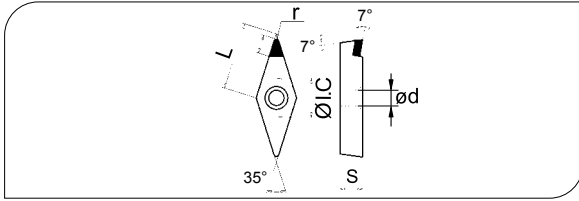

- Continuous cutting / Vollschnitt
- Continuous and interrupted cutting / Voll- und leicht unterbrochener Schnitt
- ☼ Interrupted cutting / Stark unterbrochener Schnitt

Insert Shape Schneid- plattenform	Type · Typ	Dimension (mm) Abmessung					PCD				
		L	I.C	S	d	r	YCD421				
	VCMT160404	16.6	9.525	4.76	4.4	0.4	●				
	VCMT160408	16.6	9.525	4.76	4.4	0.8	●				

Workpiece Material Werkstoffe									
H Hardened material / Gehärtete Werkstoff									
K Cast iron / Gusseisen									
N Non-ferrous material / Ne Metalle						●			

Applicable tools



Page A190 A191 A192 A233 A234

VC**

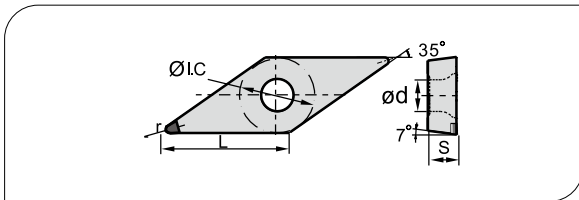

- Continuous cutting / Vollschnitt
- Continuous and interrupted cutting / Voll- und leicht unterbrochener Schnitt
- ☼ Interrupted cutting / Stark unterbrochener Schnitt

Insert Shape Schneid- plattenform	Type · Typ	Dimension (mm) Abmessung					PCD			
		L	I.C	S	d	r	YCD421			
	VCMW160404	16.6	9.525	4.76	4.4	0.4	●			
	VCMW160408	16.6	9.525	4.76	4.4	0.8	●			

Workpiece Material Werkstoffe									
H Hardened material / Gehärtete Werkstoff									
K Cast iron / Gusseisen									
N Non-ferrous material / Ne Metalle						●			

Applicable tools



Page A190 A191 A192 A233 A234

● Ex Stock / ab Lager ○ On demand / auf Anfrage

Troubleshooting - PCBN Cutting Materials

Problembehandlung - PCBN Schneidstoffe

For investigation please send us used inserts. If breakage is problem please use inserts only 80-90% of expected tool life because broken inserts almost have no information.

Für eine genaue Untersuchung schicken Sie uns bitte die gebrauchten WSP zu. Sollte Bruch das Problem sein, setzen Sie die Platte nur 80-90% der eigentlichen Standzeit ein, denn eine gebrochene Platte enthält keine Informationen mehr.







Wear phenomenon	Solution	
	Geometry	Cutting condition
Flank wear	Sharp cutting edge to reduce cutting force - smaller negative lend - change to positiv inserts	Reduce cutting speed - increase feed rate to minimise contact time
Notch wear	Bigger nose radius	Use method of altering feed rate
Crater wear/ Breakage due to crater wear	Crater wear · Breakage due to crater wear	Reduce cutting speed - increase feed rate to minimise contact time and increase distance between cutting edge and crater
Chipping due to rough condition or vibration	Bigger negative lend; angle and · or honing	Increase feed rate to reduce number of hits
Fraking	Sharp cutting edge to reduce cutting force - smaller negative lend - change to positiv inserts	Increase feed rate to reduce cutting time
Thermal crack	Sharp cutting edge to reduce cutting force - smaller negative lend - change to positiv inserts	Reduce cutting speed, feed rate and depth of cut. Use dry machining.
Chipping	Bigger negative lend	Increase cutting speed to reduce cutting force

Verschleißbild	Gegenmaßnahmen	
	Geometrie	Schnittbedingungen
Freiflächenverschleiß	Schärfere Schneidkante für weniger Schnittkraft - kleinere Negativfase - positive Platten verwenden	Schnittgeschwindigkeit reduzieren - Vorschubes erhöhen um Eingriffszeit zu reduzieren
Kerbverschleiß	Größerer Radius	“Methode des variierenden Vorschub`s” verwenden
Kolkverschleiß/ Kolkbruch		- Schnittgeschwindigkeit reduzieren - Vorschubes erhöhen um Kontaktzeit zu verringern und den Abstand zwischen Schneidkante und Kolk tasche zu vergrößern.
Ausbrüche durch Schlagwirkung oder Vibrationen	Größere Negativfase Winkel und · oder gehonte Fase	- Vorschub erhöhen, um die Anzahl der Schläge zu reduzieren
Schalenförmige Ausplatzungen	Schärfere Schneidkante für weniger Schnittkraft - kleinere Negativfase - positive Platten verwenden	- Vorschub erhöhen, um Eingriffszeit zu reduzieren
Thermische Risse · Bruch	Schärfere Schneidkante für weniger Schnittkraft - kleinere Negativfase - positive Platten verwenden	Schnittgeschwindigkeit, Vorschub und Schnitttiefe reduzieren. Trockenbearbeitung
Ausbrüche	Größere Negativfase	Schnittgeschwindigkeit erhöhen um Schnittkraft zu reduzieren

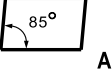
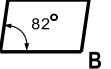
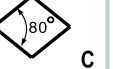
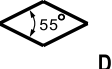
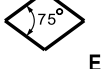
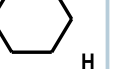
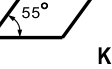
● Ex Stock / ab Lager ○ On demand / auf Anfrage

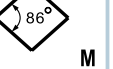
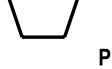

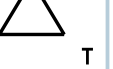

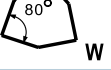

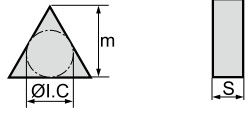
Turning · Drehen

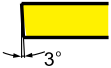

Ceramic Inserts Code Key · ISO Kennzeichnung für Keramikschnidplatten

Insert Shape / Schneidplattenform		
 A	 B	 C
 D	 E	 H
 K	 L	 M
 P	 S	 T
 V	 W	Others Z

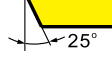
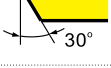
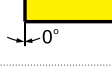
Tolerance / Toleranzklasse							
							
Code	Tolerance	Incircle Tolerance ØI.C	Thickness S	Code	Tolerance	Tolerance ØI.C	Thickness S
A	±0.005	±0.025	±0.025	J	±0.005	±0.05-±0.13	±0.025
F	±0.005	±0.013	±0.025	K	±0.013	±0.05-±0.13	±0.025
C	±0.013	±0.025	±0.025	L	±0.025	±0.05-±0.13	±0.025
H	±0.013	±0.013	±0.025	M	±0.08-±0.18	±0.05-±0.13	±0.13
E	±0.025	±0.025	±0.025	N	±0.08-±0.18	±0.05-±0.13	±0.025
G	±0.025	±0.025	±0.13	U	±0.13-±0.38	±0.08-±0.25	±0.13

T N G A

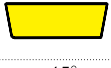
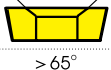
Clearance angle of main cutting edge Freiwinkel der Hauptschneide			
code	angle / Winkel	code	angle / Winkel
A	 3°	B	 5°
C	 7°	D	 15°
E	 20°	F	 25°
G	 30°	N	 0°
P	 11°	O	Others

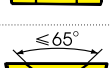
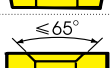
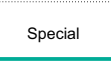
Insert type / Plattentyp		
Code	hole	Insert Section
N	No	
B	Yes	
C	Yes	
A	Yes	
W	Yes	
Q	Yes	
X	---	Special

Cutting edge length / Schneidenlänge (mm)						
Diameter of incircle (mm)	insert shape					
	C	D	S	T	V	W
3.97				06		
5.0				09		
5.56						
6.0						
6.35	06	07		11	11	
8.0						
9.525	09	11	09	16	16	06
10.0						
12.0						
12.7	12	15	12	22	22	08
15.875	16		15	27		
16.0		19				
19.05	19		19	33		
20.0						
25.0	25	25				
25.4			25			
31.75						
32						

Insert thickness / Dicke (mm)			
<p>the thickness means the distance, which between the highest part of cutting edge and insert bottom</p>			
code	Insert thickness	code	Insert thickness
02	2.38	06	6.35
T2	2.58	T6	6.75
03	3.18	07	7.94
T3	3.97	09	9.52
04	4.76	T9	9.72
T4	4.96	11	11.11
05	5.56	12	12.70
T5	5.95		

Nose radius Eckenradius	
code	Radius (mm)
00	no Radius
02	0.2
04	0.4
08	0.8
12	1.2
16	1.6
20	2.0
24	2.4
32	3.2
X	Others
Insert diameter Mo (metric)	Runde insert

12 04 08 T 020 20

Profile of cutting edges Schneidkantenausführung		
code		diagram
E	Honing Verrundung	
T	Chamfering Fase	
S	Chamfering Fase + Honing Verrundung	
F	Sharp edges Scharfe Kante	

width of chamfer Breite der Fase			
010	0.10	040	0.40
015	0.15	045	0.45
020	0.20	050	0.50
025	0.25	100	1.00
030	0.30	200	2.00
035	0.35		

angle of chamfer Winkel der Fase	
05	5°
10	10°
15	15°
20	20°
25	25°
30	30°

Turning · Drehen

Ceramic Inserts · Keramik WSP

General Turning · Allgemeine Drehbearbeitung

- Unfavorable Machining Condition
Ungünstige Bearbeitungsbedingungen
- Ideal Machining Condition
Gute Bearbeitungsbedingungen
- Normal Machining Condition
Normale Bearbeitungsbedingungen

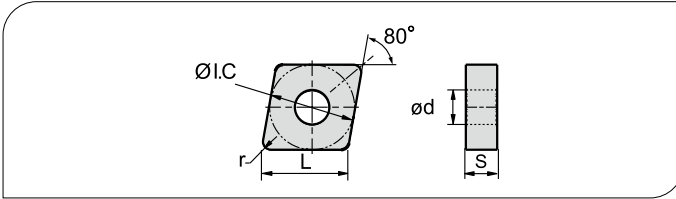

Workpiece Material Werkstoffe	P Steel / Stahl				
	K Cast iron / Gusseisen				



Insert Shape Schneid- plattenform	Type · Typ	Dimension (mm) Abmessung					Grade · Sorte		
		L	I.C	S	d	r	CA1000	CN1000	CN2000
	CNGA120404T02020	12.9	12.7	4.76	5.16	0.4		●	
	CNGA120408T02020	12.9	12.7	4.76	5.16	0.8		●	
	CNGA120412T02020	12.9	12.7	4.76	5.16	1.2		●	
	CNGA120412T03020	12.9	12.7	4.76	5.16	1.2		○	
	CNGA160608T02020	16.1	15.875	6.35	6.35	0.8		○	
	CNGA160612T02020	16.1	15.875	6.35	6.35	1.2		●	
	CNGA160616T02020	16.1	15.875	6.35	6.35	1.6		●	

Tool Holder · Klemmhalter









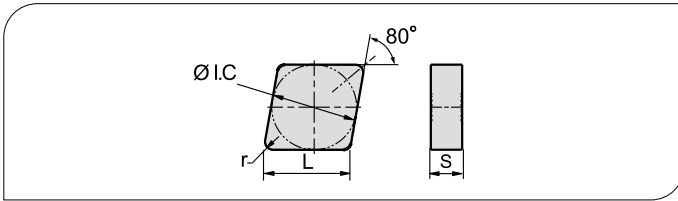





























Page · Seite A158 A159 A170 A171 A216

● Ex Stock / ab Lager ○ On demand / auf Anfrage

-  Unfavorable Machining Condition
Ungünstige Bearbeitungsbedingungen
-  Ideal Machining Condition
Gute Bearbeitungsbedingungen
-  Normal Machining Condition
Normale Bearbeitungsbedingungen



Workpiece Material Werkstoffe	Steel / Stahl			Cast iron / Gusseisen		
	P					
K						

Insert Shape Schneid- plattenform	Type · Typ	Dimension (mm) Abmessung					Grade · Sorte		
		L	I.C	S	d	r	CA1000	CN1000	CN2000
	CNGN120404T02020	12.9	12.7	4.76	-	0.4			
	CNGN120408T02020	12.9	12.7	4.76	-	0.8			
	CNGN120412T02020	12.9	12.7	4.76	-	1.2			
	CNGN120708T02020	12.9	12.7	7.94	-	0.8			
	CNGN120712T02020	12.9	12.7	7.94	-	1.2			
	CNGN120716T02020	12.9	12.7	7.94	-	1.6			
	CNGN160408T02020	16.1	15.875	4.76	-	0.8			
	CNGN160412T02020	16.1	15.875	4.76	-	1.2			
	CNGN160416T02020	16.1	15.875	4.76	-	1.6			
	CNGN160612T02020	16.1	15.875	6.35	-	1.2			
	CNGN160616T02020	16.1	15.875	6.35	-	1.6			

Tool Holder · Klemmhalter



Page · Seite A204

● Ex Stock / ab Lager ○ On demand / auf Anfrage

Turning · Drehen

Ceramic Inserts · Keramik WSP

- Unfavorable Machining Condition
Ungünstige Bearbeitungsbedingungen
- Ideal Machining Condition
Gute Bearbeitungsbedingungen
- Normal Machining Condition
Normale Bearbeitungsbedingungen

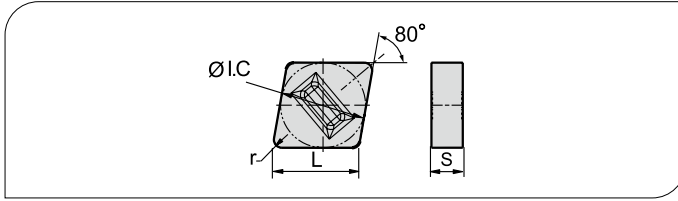

Workpiece Material Werkstoffe	P Steel / Stahl				
	K Cast iron / Gusseisen				

Insert Shape Schneid- plattenform	Type · Typ	Dimension (mm) Abmessung					Grade · Sorte		
		L	I.C	S	d	r	CA1000	CN1000	CN2000
	CNGX120712T02020	12.9	12.7	7.94	-	1.2			
	CNGX120716T02020	12.9	12.7	7.94	-	1.6			

Tool Holder · Klemmhalter



Page · Seite A208

- Unfavorable Machining Condition
Ungünstige Bearbeitungsbedingungen
- Ideal Machining Condition
Gute Bearbeitungsbedingungen
- Normal Machining Condition
Normale Bearbeitungsbedingungen

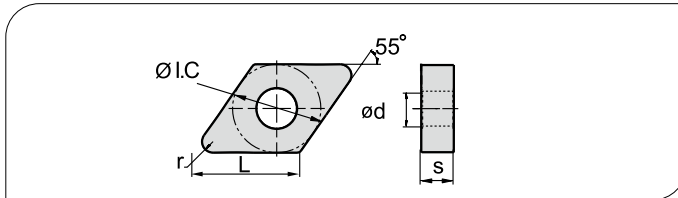

Workpiece Material Werkstoffe	P Steel / Stahl				
	K Cast iron / Gusseisen				

Insert Shape Schneid- plattenform	Type · Typ	Dimension (mm) Abmessung					Grade · Sorte		
		L	I.C	S	d	r	CA1000	CN1000	CN2000
	DNGA150604T02020	15.5	12.7	6.35	5.16	0.4			
	DNGA150608T02020	15.5	12.7	6.35	5.16	0.8			
	DNGA150612T02020	15.5	12.7	6.35	5.16	1.2			
	DNGA150616T02020	15.5	12.7	6.35	5.16	1.6			

Tool Holder · Klemmhalter



Page · Seite A160

A161



A172

A173





A218



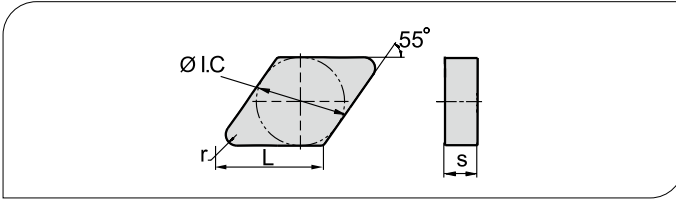







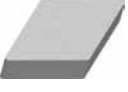

A219

- Ex Stock / ab Lager
- On demand / auf Anfrage

-  Unfavorable Machining Condition
Ungünstige Bearbeitungsbedingungen
-  Ideal Machining Condition
Gute Bearbeitungsbedingungen
-  Normal Machining Condition
Normale Bearbeitungsbedingungen





Workpiece Material Werkstoffe	P Steel / Stahl				
	K Cast iron / Gusseisen				

Insert Shape Schneid- plattenform	Type · Typ	Dimension (mm) Abmessung					Grade · Sorte		
		L	I.C	S	d	r	CA1000	CN1000	CNZ000
	DNGN150408T02020	15.5	12.7	4.76	-	0.8			
	DNGN150412T02020	15.5	12.7	4.76	-	1.2			
	DNGN150704T02020	15.5	12.7	7.94	-	0.4			
	DNGN150708T02020	15.5	12.7	7.94	-	0.8			
	DNGN150712T02020	15.5	12.7	7.94	-	1.2			
	DNGN150716T02020	15.5	12.7	7.94	-	1.6			





Tool Holder · Klemmhalter



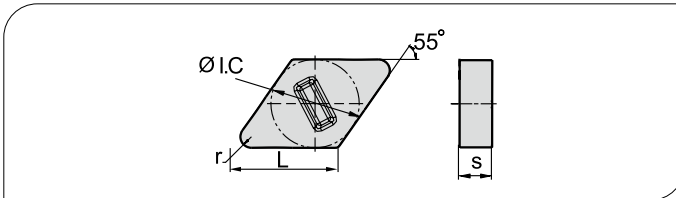

Page · Seite A205

-  Unfavorable Machining Condition
Ungünstige Bearbeitungsbedingungen
-  Ideal Machining Condition
Gute Bearbeitungsbedingungen
-  Normal Machining Condition
Normale Bearbeitungsbedingungen



Workpiece Material Werkstoffe	P Steel / Stahl				
	K Cast iron / Gusseisen				

Insert Shape Schneid- plattenform	Type · Typ	Dimension (mm) Abmessung					Grade · Sorte		
		L	I.C	S	d	r	CA1000	CN1000	CNZ000
	DNGX150712T02020	15.5	12.7	7.94	-	1.2			
	DNGX150716T02020	15.5	12.7	7.94	-	1.6			

Tool Holder · Klemmhalter



Page · Seite A208

● Ex Stock / ab Lager ○ On demand / auf Anfrage

Turning · Drehen

Ceramic Inserts · Keramik WSP

- Unfavorable Machining Condition
Ungünstige Bearbeitungsbedingungen
- Ideal Machining Condition
Gute Bearbeitungsbedingungen
- Normal Machining Condition
Normale Bearbeitungsbedingungen

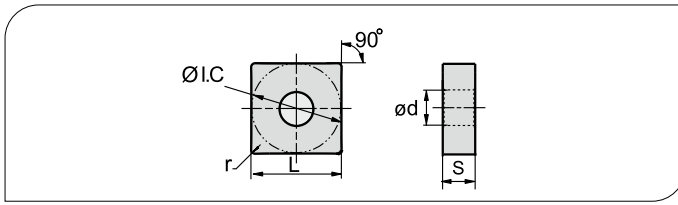

Workpiece Material Werkstoffe	P Steel / Stahl				
	K Cast iron / Gusseisen				

Insert Shape Schneid- plattenform	Type · Typ	Dimension (mm) Abmessung					Grade · Sorte		
		L	I.C	S	d	r	CA1000	CN1000	CN2000
	SNGA120404T02020	12.7	12.7	4.76	5.16	0.4		○	
	SNGA120408T02020	12.7	12.7	4.76	5.16	0.8		●	
	SNGA120412T02020	12.7	12.7	4.76	5.16	1.2		●	
	SNGA120412T03020	12.7	12.7	4.76	5.16	1.2		○	
	SNGA120416T02020	12.7	12.7	4.76	5.16	1.6		○	
	SNGA120416T03020	12.7	12.7	4.76	5.16	1.6		○	

Tool Holder · Klemmhalter



Page ·Seite A162 A163 A164 A165 A174 A175 A176



Page ·Seite A177 A221

- Unfavorable Machining Condition
Ungünstige Bearbeitungsbedingungen
- Ideal Machining Condition
Gute Bearbeitungsbedingungen
- Normal Machining Condition
Normale Bearbeitungsbedingungen

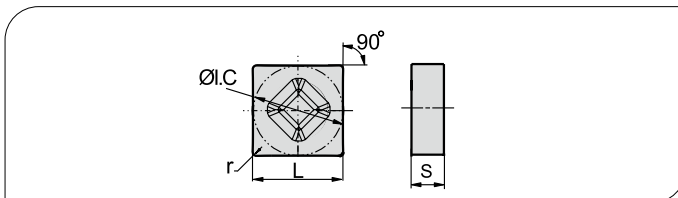

Workpiece Material Werkstoffe	P Steel / Stahl				
	K Cast iron / Gusseisen				

Insert Shape Schneid- plattenform	Type · Typ	Dimension (mm) Abmessung					Grade · Sorte		
		L	I.C	S	d	r	CA1000	CN1000	CN2000
	SNGX120708T02020	12.7	12.7	7.94	-	0.8		○	
	SNGX120712T02020	12.7	12.7	7.94	-	1.2		○	
	SNGX120716T02020	12.7	12.7	7.94	-	1.6		●	

Tool Holder · Klemmhalter



Page ·Seite A209

● Ex Stock / ab Lager ○ On demand / auf Anfrage

- Unfavorable Machining Condition
Ungünstige Bearbeitungsbedingungen
- Ideal Machining Condition
Gute Bearbeitungsbedingungen
- Normal Machining Condition
Normale Bearbeitungsbedingungen

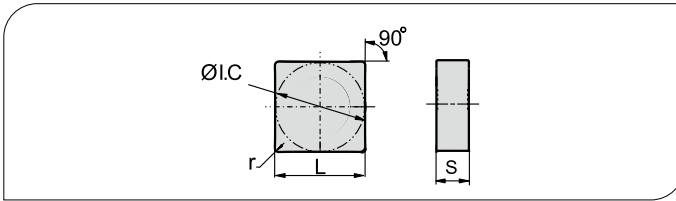

Workpiece Material Werkstoffe	P Steel / Stahl				
	K Cast iron / Gusseisen				

Insert Shape Schneid- plattenform	Type · Typ	Dimension (mm) Abmessung					Grade · Sorte		
		L	I.C	S	d	r	CA1000	CN1000	CN2000
	SNGN090308T01020	9.525	9.525	3.18	-	0.8	○		
	SNGN090312T01020	9.525	9.525	3.18	-	1.2	○		
	SNGN120404T02020	12.7	12.7	4.76	-	0.4	○		
	SNGN120408T02020	12.7	12.7	4.76	-	0.8	●	●	○
	SNGN120412T02020	12.7	12.7	4.76	-	1.2	●	●	●
	SNGN120412T03020	12.7	12.7	4.76	-	1.2		○	
	SNGN120416T02020	12.7	12.7	4.76	-	1.6	○	○	○
	SNGN120704T02020	12.7	12.7	7.94	-	0.4	●		
	SNGN120708T02020	12.7	12.7	7.94	-	0.8	○	○	●
	SNGN120712T02020	12.7	12.7	7.94	-	1.2	●	●	○
	SNGN120716T02020	12.7	12.7	7.94	-	1.6	●		●
	SNGN150708T02020	15.875	15.875	7.94	-	0.8	○		
	SNGN150712T02020	15.875	15.875	7.94	-	1.2	●	○	○
	SNGN150716T02020	15.875	15.875	7.94	-	1.6	●	○	○
	SNGN190708T03020	19.05	19.05	7.94	-	0.8	○		
	SNGN190712T03020	19.05	19.05	7.94	-	1.2	○		
	SNGN190716T03020	19.05	19.05	7.94	-	1.6	○		
	SNGN190724T03020	19.05	19.05	7.94	-	2.4	○		
	SNGN191024T04020	19.05	19.05	10.05	-	2.4	○		
	SNGN251024T10015	25.4	25.4	10.05	-	2.4	○		

Tool Holder · Klemmhalter





Turning · Drehen





Ceramic Inserts · Keramik WSP

A

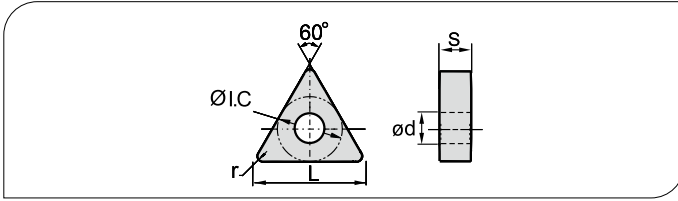
General Turning · Allgemeine Drehbearbeitung

-  Unfavorable Machining Condition
Ungünstige Bearbeitungsbedingungen
-  Ideal Machining Condition
Gute Bearbeitungsbedingungen
-  Normal Machining Condition
Normale Bearbeitungsbedingungen



Workpiece Material Werkstoffe	P Steel / Stahl				
	K Cast iron / Gusseisen				

Insert Shape Schneid- plattenform	Type · Typ	Dimension (mm) Abmessung					Grade · Sorte		
		L	I.C	S	d	r	CA1000	CN1000	CN2000
	TNGA160404T01020	16.50	9.525	4.76	3.86	0.4		●	
	TNGA160408T02020	16.50	9.525	4.76	3.86	0.8		●	
	TNGA160412T02020	16.50	9.525	4.76	3.86	1.2		●	
	TNGA220408T02020	22.00	12.7	4.76	5.16	0.8		○	
	TNGA220412T02020	22.00	12.7	4.76	5.16	1.2		○	
	TNGA220416T02020	22.00	12.7	4.76	5.16	1.6		○	
	TNGA220416T03020	22.00	12.7	4.76	5.16	1.6		○	

Tool Holder · Klemmhalter



Page · Seite A166

A167

A168



A178

A179





A180



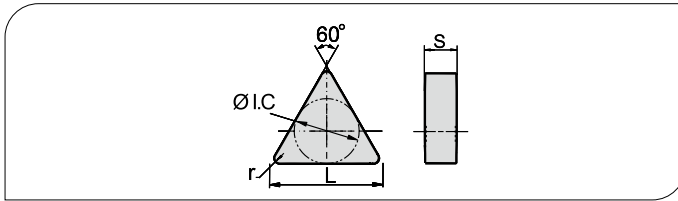

























A222

● Ex Stock / ab Lager ○ On demand / auf Anfrage

-  Unfavorable Machining Condition
Ungünstige Bearbeitungsbedingungen
-  Ideal Machining Condition
Gute Bearbeitungsbedingungen
-  Normal Machining Condition
Normale Bearbeitungsbedingungen



Workpiece Material Werkstoffe	P Steel / Stahl				
	K Cast iron / Gusseisen				

Insert Shape Schneid- plattenform	Type · Typ	Dimension (mm) Abmessung					Grade · Sorte		
		L	I.C	S	d	r	CA1000	CN1000	CN2000
	TNGN160404T02020	16.50	9.525	4.76	-	0.4			
	TNGN160408T02020	16.50	9.525	4.76	-	0.8			
	TNGN160412T02020	16.50	9.525	4.76	-	1.2			
	TNGN160708T02020	16.50	9.525	7.94	-	0.8			
	TNGN160712T02020	16.50	9.525	7.94	-	1.2			
	TNGN160716T02020	16.50	9.525	7.94	-	1.6			
	TNGN220408T02020	22.00	12.7	4.76	-	0.8			
	TNGN220412T02020	22.00	12.7	4.76	-	1.2			
	TNGN220416T02020	22.00	12.7	4.76	-	1.6			
	TNGN220712T02020	22.00	12.7	7.94	-	1.2			
	TNGN220716T02020	22.00	12.7	7.94	-	1.6			

Tool Holder · Klemmhalter





Page · Seite A204

Turning · Drehen

Ceramic Inserts · Keramik WSP

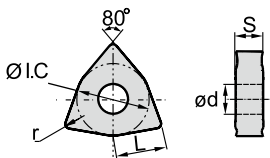
- Unfavorable Machining Condition
Ungünstige Bearbeitungsbedingungen
- Ideal Machining Condition
Gute Bearbeitungsbedingungen
- Normal Machining Condition
Normale Bearbeitungsbedingungen



Insert Shape Schneid- plattenform	Type · Typ	Dimension (mm) Abmessung					Grade · Sorte		
		L	I.C	S	d	r	CA1000	CN1000	CN2000
	WNGA080408T02020	8.69	12.7	4.76	5.16	0.8		●	
	WNGA080412T02020	8.69	12.7	4.76	5.16	1.2		●	
	WNGA080416T02020	8.69	12.7	4.76	5.16	1.6		●	

Tool Holder · Klemmhalter





Page · Seite A169

A183

A223

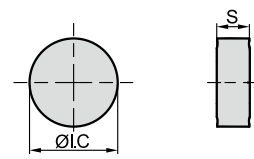
- Unfavorable Machining Condition
Ungünstige Bearbeitungsbedingungen
- Ideal Machining Condition
Gute Bearbeitungsbedingungen
- Normal Machining Condition
Normale Bearbeitungsbedingungen



Insert Shape Schneid- plattenform	Type · Typ	Dimension (mm) Abmessung					Grade · Sorte		
		L	I.C	S	d	r	CA1000	CN1000	CN2000
	RNGN090400T02020	---	9.53	4.76	---	---	○		
	RNGN120400T02020	---	12.7	4.76	---	---	○	○	●
	RNGN120700T02020	---	12.7	7.94	---	---	●	○	●
	RNGN150700T02020	---	15.875	7.94	---	---	●	○	
	RNGN190700T03020	---	19.05	7.94	---	---	○	○	○
	RNGN251000T05020	---	25.40	10.05	---	---	○	○	

Tool Holder · Klemmhalter



Page · Seite A207



Turning · Drehen

Application of turning tools · Anwendung von Drehwerkzeugen

● External and internal turning · Außen- und Innenbearbeitung

External Turning · Außenbearbeitung	Type · Typ					
	PCBNR/ L**	PSBNR/ L**	PSSN *	PTGNR/ L**	PTTNR/ L**	MCBNR/ L**
	MSBNR/ L**	MSRNR/ L**	MTGNR/ L**	MTJNR/ L**	SCACR/ L**	SSBCR/ L**
	SSSCR/ L**	STACR/ L**	STGCR/ L**	STTCR/ L**	SWACR/ L**	

External facing & turning · Außen- & Planbearbeitung	Type · Typ	
	PCLNR/ L**	PWLNR/ L**
	MCLNR/ L**	MWLNr/ L**
	SCLCR/ L**	

Profiling · Profilbearbeitung	Type · Typ			
	PDNNR/ L**	PSDNN**	MDPNN**	MSDNN**
	MVVNN**	MRDNN**	SDNCN**	SVVBN**
	SVVCN**	SSDCN**	SRDCN**	CKNNR/ L**

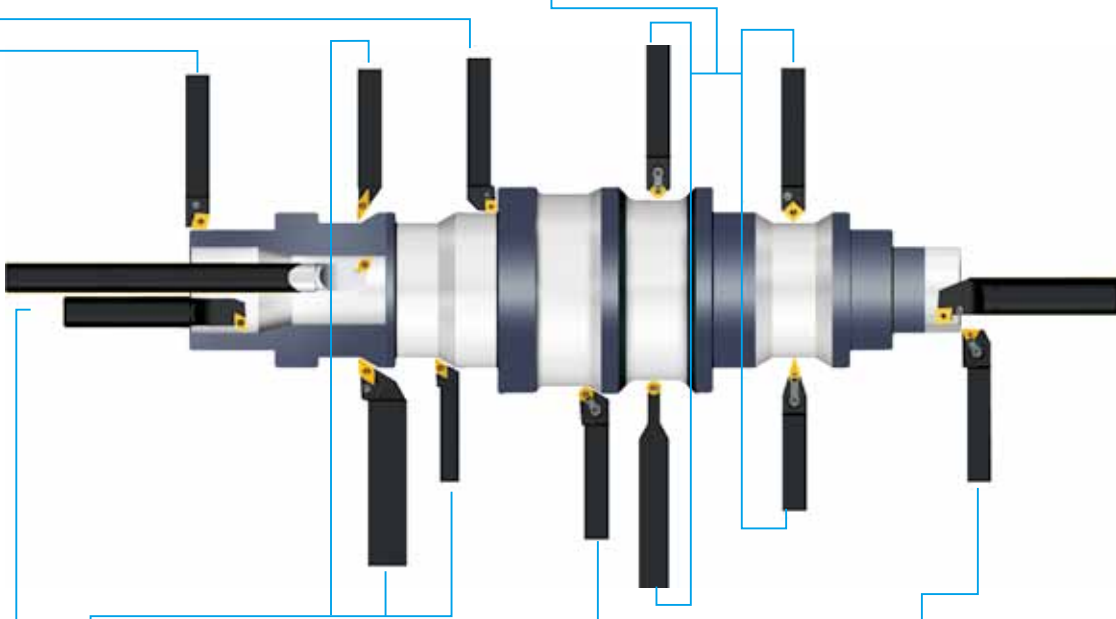

Profiling · Profilbearbeit.	Type · Typ		
	PDJNR/ L**	MDJNR/ L**	MVJNR/ L**
	SDACR/ L**	SDJCR/ L**	SVABR/ L**
	SVJBR/ L**	SVJCR/ L**	CKJNR/ L**

Profiling · Profilbearbeit.	Type · Typ
	MRGNR/ L**
	SRGCR/ L**

Facing · Planbearbeitung	Type · Typ
	PSKNR/ L**
	PTFNR/ L**
	MSKNR/ L**
	MTFNR/ L**
	SSKCR/ L**
	STFCR/ L**

Toolholders for internal turning (Steel toolholder) · Klemmhalter Innenbearbeitung (Stahlhaustführung)						
	S*-PSKNR/ L*	S*-PCLNR/ L*	S*-PDSNR/ L*	S*-PDUNR/ L*	S*-SDQCR/ L*	S*-SDZCR/ L*
	S*-PTFNR/ L*	S*-PWLNR/ L*		S*-SDUCR/ L*	S*-SDQPR/ L*	
	S*-SCFCR*	S*-SCLCR/ L*		S*-SDUNR/ L*	S*-SVQBR/ L*	
	S*-SSKCR/ L*	S*-SCLPR/ L*		S*-SDUPR/ L*	S*-SVQCR/ L*	
	S*-STFCR/ L*			S*-SVUBR/ L*		
	S*-STUPR/ L*			S*-SVUCR/ L*		

Toolholders for internal turning (Cemented carbide) · Klemmhalter Innenbearbeitung (Hartmetall)				
	C*-STUPR/ L*	C*-SCLPR/ L*	C*-SDUPR/ L*	C*-SDQPR/ L*
		C*-SVUCR/ L*	C*-SVQCR/ L*	

Turning · Drehen

Application of turning tools · Anwendung von Drehwerkzeugen

● Parting, Grooving and Threading Tools · Abstech-, Einstech-, und Gewindewerkzeug

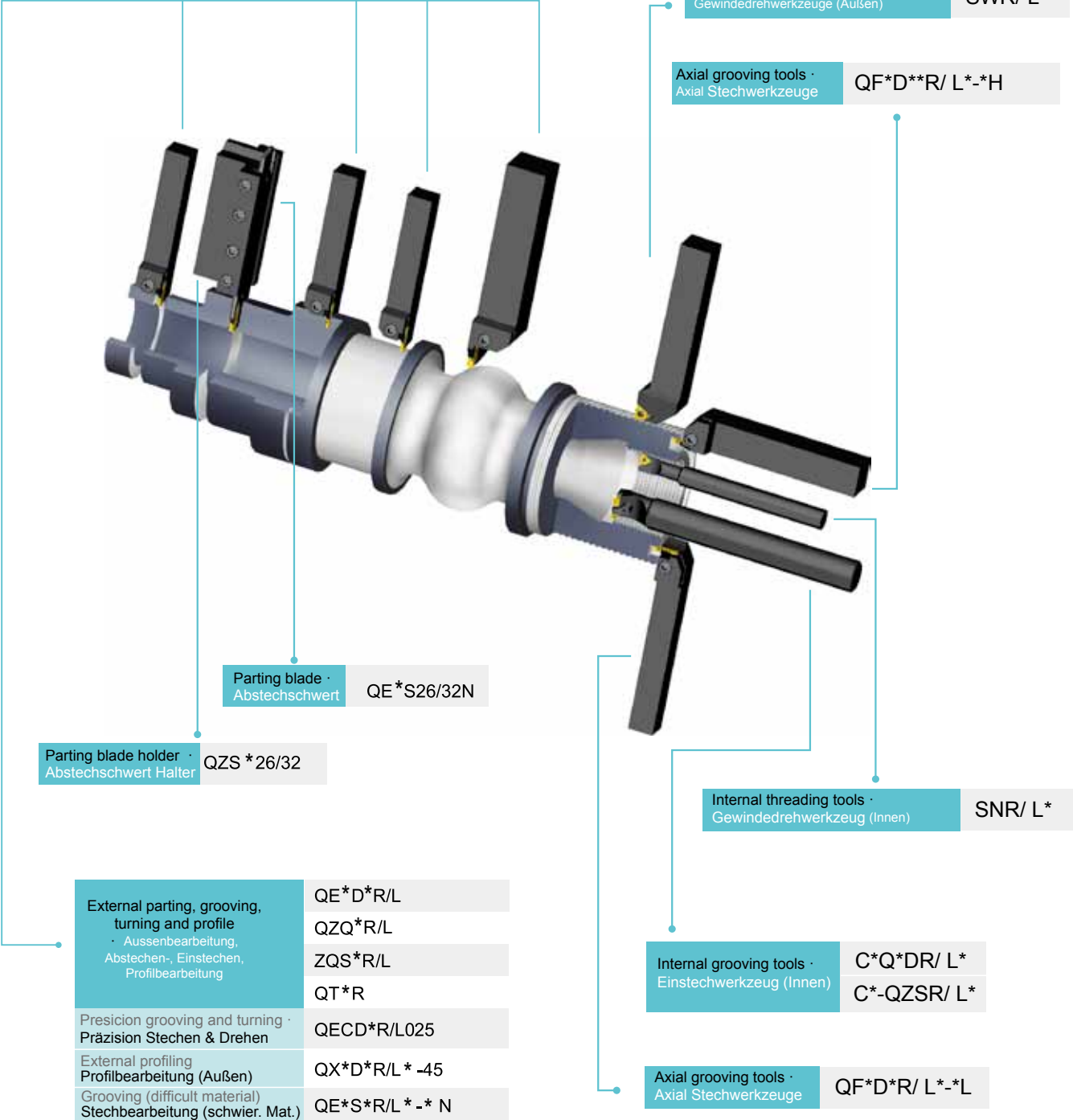

A

General Turning · Allgemeine Drehbearbeitung

Application of turning tools · Anwendung von Drehwerkzeugen

Turning · Drehen

External Turning Tools · Drehwerkzeuge zur Außenbearbeitung

Turning tools overview · Drehwerkzeuge Übersicht **A152-A155**

Turning tools code key · ISO Kennzeichnung **A156-A157**

**Detailed table of external turning tools
Drehwerkzeuge zur Außenbearbeitung** **A158-A210**

Turning toolholders by P type clamping · Drehwerkzeuge / P Klemmung A158-A169



Turning toolholders by M type clamping · Drehwerkzeuge / M Klemmung A170-A184

Turning toolholders by S type clamping · Drehwerkzeuge / S Klemmung A185-A202

Turning toolholders by C type clamping · Drehwerkzeuge / C Klemmung A203





















**Detailed table of external turning tools (Ceramic)
Drehwerkzeuge zur Außenbearbeitung für Kermik WSP** **A204-A210**

External turning tools Overview · Drehwerkzeugen zur Außenbearbeitung Übersicht

Clamping system Klemmsystem	Tool Type Werkzeug Typ	Approach angle Einstellwinkel	Turning Application · Anwendung						Workpiece · Werkstück		Page · Seite
			External turning Außenbearbeit.	Facing Planbearbeit.	Ext., turning & facing · Außen, & Planbearbeit.	Profiling Profilbearbeit.	Profiling Profilbearbeit.	Profiling Profilbearbeit..	Stable Stabil	Unstable Instabil	
											
P	 PCBNR/ L	75	✓						✓		A158
	 PCLNR/ L	95			✓				✓		A159
	 PDJNR/ L	93					✓		✓	✓	A160
	 PDNNR/ L	63						✓	✓		A161
	 PSBNR/ L	75	✓						✓		A162
	 PSDNN	45						✓	✓		A163
	 PSKNR/ L	75		✓					✓		A164
	 PSSNR/ L	45	✓						✓		A165
	 PTFNR/ L	90		✓					✓	✓	A166
	 PTTNR/ L	60	✓						✓		A167
	 PTGNR/ L	90	✓						✓	✓	A168
	 PWLNR/ L	95			✓				✓		A169

✓ Recommended · Empfehlung

External turning tools Overview · Drehwerkzeugen zur Außenbearbeitung Übersicht

Clamping system Klemmsystem	Tool Type Werkzeug Typ	Approach angle Einstellwinkel	Turning Application · Anwendung						Workpiece · Werkstück		Page · Seite
			External turning Außenbearbeit.	Facing Planbearbeit.	Ext., turning & facing · Außen, & Planbearbeit.	Profiling Profilbearbeit.	Profiling Profilbearbeit.	Profiling Profilbearbeit.	Stable Stabil	Unstable Instabil	
											
M	 MCBNR/ L	75	✓						✓		A170
	 MCLNR/ L	95			✓				✓		A171
	 MDJNR/ L	93					✓		✓	✓	A172
	 MDPNN	62.5						✓	✓		A173
	 MSBNR/ L	75	✓						✓		A174
	 MSRNR/ L	75	✓						✓		A175
	 MSKNR/ L	75		✓					✓		A176
	 MSDNN	45						✓	✓		A177
	 MTGNR/ L	90	✓						✓	✓	A178
	 MTJNR/ L	93	✓						✓		A179
	 MTFNR/ L	90		✓					✓		A180
	 MNVNN	72.5						✓	✓		A181
 MVJNR/ L	93					✓		✓	✓	A182	





















✓ Recommended · Empfehlung

Turning · Drehen

External turning tools Overview · Drehwerkzeugen zur Außenbearbeitung Übersicht

A

General Turning · Allgemeine Drehbearbeitung

Clamping system Klemmsystem	Tool Type Werkzeug Typ	Approach angle Einstellwinkel	Turning Application · Anwendung						Workpiece · Werkstück		Page · Seite
			External turning Außenbearbeit.	Facing Planbearbeit.	Ext., turning & facing · Außen, & Planbearbeit.	Profiling Profilbearbeit.	Profiling Profilbearbeit.	Profiling Profilbearbeit..	Stable Stabil	Unstable Instabil	
											
M	MWLN/ L 	95			✓				✓		A183
	MRGN/ L 					✓			✓		A184
	MRDNN 							✓	✓		A184
S	SCAC/ L 	90	✓						✓	✓	A185
	SCLCR/ L 	95			✓				✓	✓	A186
	SDAC/ L 	90					✓		✓	✓	A187
	SDJCR/ L 	93					✓		✓	✓	A188
	SDNCN 	63						✓	✓	✓	A189
	SVJBR/ L 	93					✓		✓	✓	A190
	SVABR/ L 	90					✓		✓	✓	A191
	SVVBN 	72.5						✓	✓	✓	A192
	SVVCN 	72.5						✓	✓	✓	A193
	SVJCR/ L 	93					✓		✓	✓	A194

✓ Recommended · Empfehlung

Turning · Drehen







External turning tools Overview · Drehwerkzeugen zur Außenbearbeitung Übersicht

Clamping system Klemmsystem	Tool Type Werkzeug Typ	Approach angle Einstellwinkel	Turning Application · Anwendung						Workpiece · Werkstück		Page · Seite	
			External turning Außenbearbeit.	Facing Planbearbeit.	Ext., turning & facing · Außen, & Planbearbeit.	Profiling Profilbearbeit.	Profiling Profilbearbeit.	Profiling Profilbearbeit..	Stable · Stabil	Unstable · Instabil		
												
S	SSBCR/ L 	75	✓							✓		A195
	SSDCN 	45							✓	✓		A195
	SSKCR/ L 	75		✓						✓		A196
	SSSCR/ L 	45	✓							✓		A196
	STACR/ L 	90	✓							✓	✓	A197
	STFCR/ L 	90		✓						✓		A197
	STGCR/ L 	91	✓							✓	✓	A198
	STTCR/ L 	60	✓							✓		A199
	SWACR/ L 	90	✓							✓	✓	A200
	SRDCN 								✓	✓		A201
	SRGCR/ L 						✓			✓		A202
C	CKJNR/ L 	93						✓		✓		A203
	CKNNR/ L 	63							✓	✓		A203

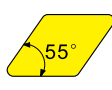
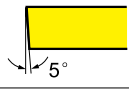
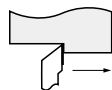

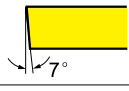
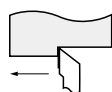

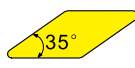
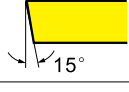

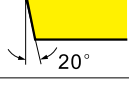
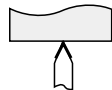
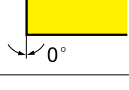
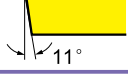
✓ Recommended · Empfehlung

Turning · Drehen

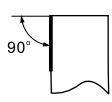
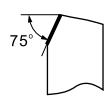
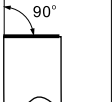
External turning tools Code Key · Drehwerkzeugen zur Außenbearbeitung ISO Kennzeichnung

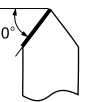
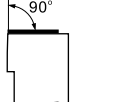
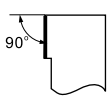
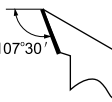
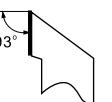
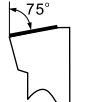
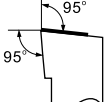
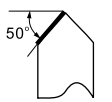
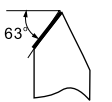
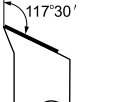
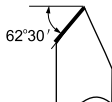
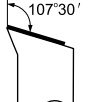
Clamping System Klemmsystem	Insert shape Plattenform		Clearance angle of major cutting edge Freiwinkel der Hauptschneide	Holder execution Halteraussführung
P lever lock clamping Kniehebel Spannsystem	 C	 D	 B	 L
M Screw clamping Schrauben Spannsystem	 R	 S	 C	 R
S Wedge lock clamping Pratzenkeilklemmung	 T	 V	 D	 R
C Overhead clamping Pratzenklemmung	 W		 E	 N
			 N	
			 P	

P C L N L

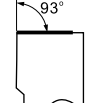
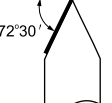
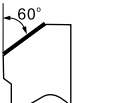
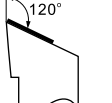
Holder style and lead angle Halteraform und Anstellwinkel							
A	B	C	D	E	F	G	H
 90°	 75°	 90°	 45°	 60°	 90°	 90°	 107°30'
 93°	 75°	 95°	 50°	 63°	 117°30'	 62°30'	 107°30'
 75°	 45°	 60°	 93°	 72°30'	 60°	 120°	

Height
Schafthöhe

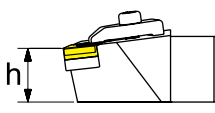

code	Height / Höhe
12	12
16	16
20	20
25	25
32	32
40	40
50	50

Shank width
Schaftbreite

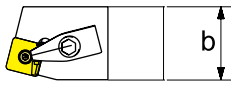





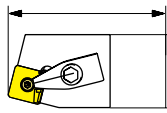

code	Width / Breite
12	12
16	16
20	20
25	25
32	32
40	40
50	50

Tool length
Halterlänge

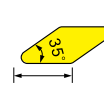

code	Length / Länge
H	100
K	125
M	150
P	170
Q	180
R	200
S	250
T	300

25 25 M 12

Cutting edge length Schneidkantenlänge							
insert shape Plattenform	C	D	R	S	T	V	W
							
Diameter of incircle Durchmesser (mm)	Cutting edge length / Schneidkantenlänge						
5.556	---	---	---	---	09	---	---
6.350	06	07	---	---	11	---	---
9.525	09	11	09	09	16	16	06
12.700	12	15	12	12	22	22	08
15.875	16	19	15	15	27	---	---
19.050	19	---	19	19	33	---	---
25.400	25	---	25	25	44	---	---
32.000	---	---	32	---	---	---	---

Turning · Drehen

External turning tools · Drehwerkzeugen zur Außenbearbeitung

CN** Toolholder · Halter

P-Clamping · P-Halter





PCBNR/ L

Kr:75°

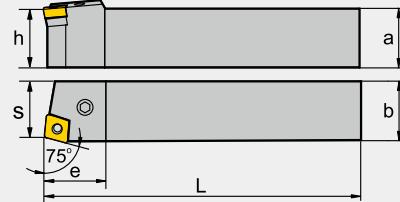















R type
Rechtsausführung



Type · Typ		Stock Lager Lager		Dimension (mm) Abmessung						Screw Schraube	Shim Unterlage	Wrench Schlüssel	Lever Kniehebel	Shim pin Rohrstift
		R	L	a	b	L	h	s	e					
PCBNR/ L	2020K12	●	●	20	20	125	20	17	27	LEM8×21	C12AP	WH30L	L4	SP4
	2525M12	●	●	25	25	150	25	22	27					
	3232P12	●	●	32	32	170	32	27	27					
	2525M16	●	●	25	25	150	25	22	33	LEM8×25	C16AP	WH30L	L5	SP5
	3232P16	●	●	32	32	170	32	27	33					
	3232P19	●	●	32	32	170	32	27	38	LEM10×27	C19AP	WH40L	L6	SP6
	4040S19	●	●	40	40	250	40	35	38					
	4040S2507	●	●	40	40	250	40	35	50	LEM12×36A	C25AP-07	WH50L	L8	SP8
4040S2509	●	●	40	40	250	40	35	50	C25AP					

Applicable inserts
Wendeschneidplatten

Application Anwendung	Finishing Schlichten	Semi-Finishing Mittlere Bearbeitung	Rough machining Schruppen	Heavy Duty Schwerzerspanung	Cast iron Grauguss Bearbeit.
Inserts WSP	DF  A46	PM  A47	DR  A49	HDR  A50	 A51
	SF  A46	DM  A48	DR  A50		
	EF  A46	EM  A48	ER  A50		
	NF  A47	NM  A49	ER  A50		
PCBNR/L**K / M / P12	CN**1204**	CN**1204**	CN**1204**	CN**1204**	CN**1204**
PCBNR/L**M / P16	CN**1606**	CN**1606**	CN**1606**	CN**1606**	CN**1606**
PCBNR/L**P / S19		CN**1906**	CN**1906**	CN**1906**	CN**1906**
PCBNR/L**S2507			CN**2507**		
PCBNR/L**S2509			CN**2509**		

● ex stock · ab Lager ○ on demand · Anfrage

CN** Toolholder · Halter

P-Clamping · P-Halter

PCLNR/L

Kr:95°

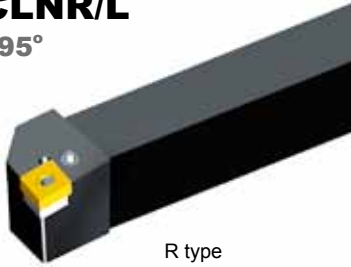

R type
Rechtsausführung

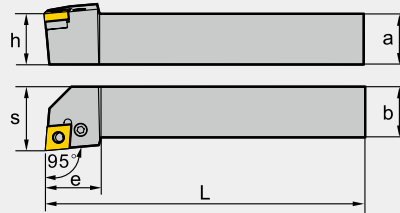

Type · Typ		Stock Lager		Dimension (mm) Abmessung					Screw Schraube	Shim Unterlage	Wrench Schlüssel	Lever Kniehebel	Shim pin Rohrstift	
		R	L	a	b	L	h	s	e					
PCLNR/ L	1616H09	●	●	16	16	100	16	20	20	LEM6×13.4A	C09AP	WH25L	L3	SP10
	2020K09	●	●	20	20	125	20	25	22					
	2525M09	●	●	25	25	150	25	32	22					
	2020K12	●	●	20	20	125	20	25	28	LEM8×21	C12AP	WH30L	L4	SP4
	2525M12	●	●	25	25	150	25	32	28					
	3232P12	●	●	32	32	170	32	40	28	LEM8×25	C16AP	WH30L	L5	SP5
	2525M16	●	●	25	25	150	25	32	33					
	3232P16	●	●	32	32	170	32	40	33	LEM10×27	C19AP	WH40L	L6	SP6
	3232P19	●	●	32	32	170	32	40	38					
	4040S19	●	●	40	40	250	40	50	38	LEM12×36A	C25AP-07 C25AP	WH50L	L8	SP8
4040S2507	●	●	40	40	250	40	50	49						
4040S2509	●	●	40	40	250	40	50	49						

Applicable insert
Wendeschneidplatten

Application Anwendung	Finishing Schlichten	Semi-Finishing Mittlere Bearbeitung	Roughing Schruppen	Heavy Duty Schwerzerspannung	Cast iron Grauguss Bearbeit.	PCBN · PCD PCBN · PKD
insert shape Schneidplattenform	DF A46	PM A47	DR A49	HDR A50	 A51	 A118
	WG A46	DM A48	DR A50			
	SF A46	EM A48	ER A50			
	EF A46	NM A49	ER A50			
	NF A47					
PCLNR/L**H / K / M09	CN**0903**	CN**0903**				
PCLNR/L**K / M / P12	CN**1204**	CN**1204**	CN**1204**	CN**1204**	CN**1204**	CN**1204**
PCLNR/L**M / P16	CN**1606**	CN**1606**	CN**1606**	CN**1606**	CN**1606**	
PCLNR/L**P / S19		CN**1906**	CN**1906**	CN**1906**	CN**1906**	
PCLNR/L**S2507			CN**2507**			
PCLNR/L**S2509			CN**2509**			

Turning · Drehen

External turning tools · Drehwerkzeugen zur Außenbearbeitung

DN** Toolholder · Halter

P-Clamping · P-Halter

PDJNR/ L

Kr:93°

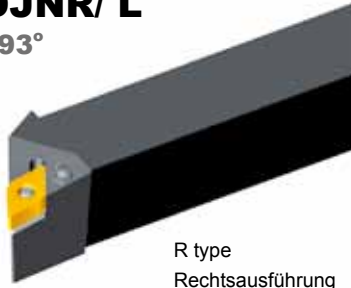



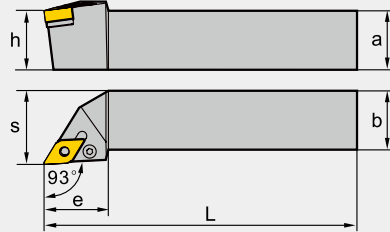













R type
Rechtsausführung



Type · Typ		Stock Lager		Dimension (mm) Abmessung						Screw Schraube	Shim Unterlage	Wrench Schlüssel	Lever Kniehebel	Shim pin Rohrstift
		R	L	a	b	L	h	s	e					
PDJNR/ L	1616H11	●	●	16	16	100	16	20	25	LEM6×13.4A	D11AP	WH25L	L3	SP3
	2020K11	●	●	20	20	125	20	25	25					
	2525M11	●	●	25	25	150	25	32	30					
	2020K15	●	●	20	20	125	20	25	35	LEM8×21	D15AP	WH30L	L4B	SP4
	2525M15	●	●	25	25	150	25	32	35					
	3232P15	●	●	32	32	170	32	40	35	LEM8×21	D15AP	WH30L	L4	SP4
	2020K15-3	●	●	20	20	125	20	25	35					
	2525M15-3	●	●	25	25	150	25	32	35					
3232P15-3	●	●	32	32	170	32	40	35						

Applicable insert
Wendeschneidplatten

Application Anwendung	Finishing Schlichten	Semi-Finishing Mittlere Bearbeitung	Roughing Schruppen	Heavy Duty Schwerzerspanung	Cast iron machining Grauguss Bearbeit.	PCBN · PCD PCBN · PKD
insert shape Schneidplattenform	DF  A53	PM  A55	DR Double-side  A56	HDR  A58	 A58	 A119
	WG  A53	DM  A55	DR Single-side  A58			
	SF  A53	EM  A56	ER Double-side  A58			
	EF  A54	NM  A56	ER Single-side  A58			
	NF  A54					
Type · Typ	PDJNR/L**H / K / M11	DN**1104**	DN**1104**		DN**1104**	
	PDJNR/L**K / M / P15	DN**1506**	DN**1506**	DN**1506**	DN**1506**	DN**1506**
	PDJNR/L**K / M / P15-3	DN**1504**	DN**1504**		DN**1504**	DN**1504**

● ex stock · ab Lager ○ on demand · Anfrage

DN** Toolholder · Halter

P-Clamping · P-Halter

PDNNR/ L

Kr:63°

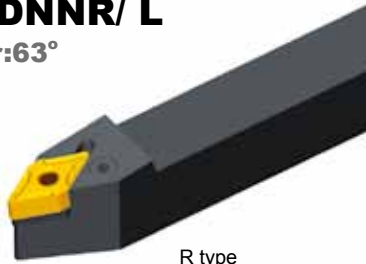

R type
Rechtsausführung

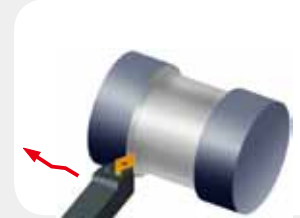
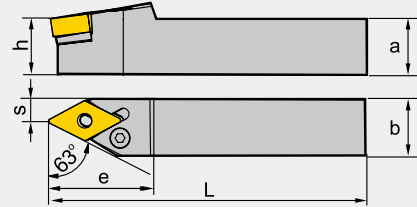

Type · Typ		Stock Lager		Dimension (mm) Abmessung						Screw Schraube	Shim Unterlage	Wrench Schlüssel	Lever Kniehebel	Shim pin Rohrstift
		R	L	a	b	L	h	s	e					
PDNNR/ L	2020K15	●	●	20	20	125	20	8	37	LEM8×21	D15AP	WH30L	L4B	SP4
	2525M15	●	●	25	25	150	25	12.5	37					
	3232P15	●	●	32	32	170	32	16	37					
	2020K15-3	●	●	20	20	125	20	8	37	LEM8×21	D15AP	WH30L	L4	SP4
	2525M15-3	●	●	25	25	150	25	12.5	37					
	3232P15-3	●	●	32	32	170	32	16	37					

Applicable insert
Wendeschneidplatten

Application Anwendung	Finishing Schlichten	Semi-Finishing Mittlere Bearbeitung	Roughing Schruppen	Heavy Duty Schwerzerspannung	Cast iron machining Grauguss Bearbeit.	PCBN · PCD PCBN · PKD
insert shape Schneidplattenform	DF A53	PM A55	DR Double-side A56	HDR A58	A58	A119
	SF A53	DM A55	DR Single-side A58			
	EF A54	EM A56	ER Double-side A58			
	NF A54	NM A56	ER Single-side A58			
Type · Typ	PDNNR/L**K / M/ P15	DN**1506**	DN**1506**	DN**1506**	DN**1506**	DN**1506**
	PDNNR/L**K / M/ P15-3	DN**1504**	DN**1504**		DN**1504**	DN**1504**

Turning · Drehen

External turning tools · Drehwerkzeuge zur Außenbearbeitung

SN** Toolholder · Halter

P-Clamping · P-Halter

PSBNR/ L

Kr:75°

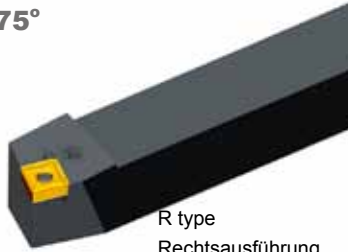

R type
Rechtsausführung



Type · Typ	Stock Lager		Dimension (mm) Abmessung						Screw Schraube	Shim Unterlage	Wrench Schlüssel	Lever Kniehebel	Shim pin Rohrstift	
	R	L	a	b	L	h	s	e						
PSBNR/ L	1616H09	●	●	16	16	100	16	13	21	LEM6×13.4A	S09AP	WH25L	L3	SP10
	2020K09	●	●	20	20	125	20	17	23					
	2020K12	●	●	20	20	125	20	17	28					
	2525M12	●	●	25	25	125	25	22	28	LEM8×21	S12AP	WH30L	L4	SP4
	3225P12	●	●	32	25	170	32	22	28					
	3232P12	●	●	32	32	170	32	27	28					
	2525M15	●	●	25	25	150	25	22	35	LEM8×25	S15AP	WH30L	L5	SP5
	3232P15	●	●	32	32	170	32	27	35					
	3232P19	●	●	32	32	170	32	27	40	LEM10×27	S19AP	WH40L	L6	SP6
	4040S19	●	●	40	40	250	40	35	40					
4040S2507	●	●	40	40	250	40	35	48	LEM12×36A	S25AP	WH50L	L8	SP8	
4040S2509	●	●	40	40	250	40	35	48		S25AP-09				

Applicable insert
Wendeschneidplatten

Application Anwendung	Finishing Schlichten	Semi-Finishing Mittlere Bearbeitung	Roughing Schruppen	Heavy Duty Schwerzerspannung	Cast iron machining Grauguss Bearbeit.	PCBN · PCD PCBN · PKD
insert shape Schneidplattenform	DF A59	PM A60	DR Double-side A62	HDR A64	A65	A120
	EF A59	DM A61	DR Single-side A62			
	SF A60	EM A61	ER Double-side A63			
		NM A62	ER Single-side A63			
PSBNR/L**H / K09	SN**0903**	SN**0903**			SN**0903**	
PSBNR/L**K / M / P12	SN**1204**	SN**1204**	SN**1204**	SN**1204**	SN**1204**	SN**1204**
PSBNR/L**M / P15	SN**1506**	SN**1506**	SN**1506**	SN**1506**	SN**1506**	
PSBNR/L**P / S19		SN**1906**	SN**1906**	SN**1906**	SN**1906**	
PSBNR/L**S2507			SN**2507**	SN**2507**		
PSBNR/L**S2509			SN**2509**	SN**2509**		

● ex stock · ab Lager ○ on demand · Anfrage





SN** Toolholder · Halter

P-Clamping · P-Halter

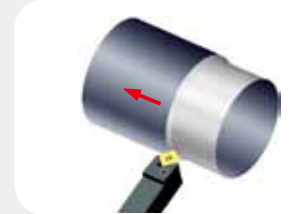
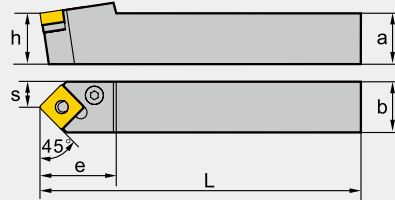
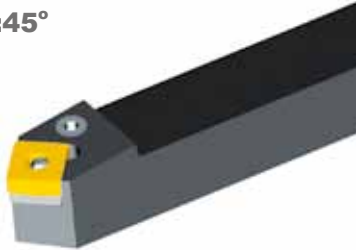













PSDNN

Kr:45°



Type · Typ		Stock Lager	Dimension (mm) Abmessung						Screw Schraube	Shim Unterlage	Wrench Schlüssel	Lever Kniehebel	Shim pin Rohrstift
			a	b	L	h	s	e					
PSDNN	1212F09		12	12	80	12	6	21	LEM5×12B	—	WH20L	L3B	—
	1616H09	●	16	16	100	16	8	23	LEM6×13.4A	S09AP	WH25L	L3	SP10
	2020K12	●	20	20	125	20	10	30	LEM8×21	S12AP	WH30L	L4	SP4
	2525M12	●	20	20	150	20	12.5	30					
	3232P12	●	32	32	170	32	16	40	LEM8×25	S15AP	WH30L	L5	SP5
	2525M15	●	25	25	150	25	12.5	40					
	3232P15	●	32	32	170	32	16	40	LEM10×27	S19AP	WH40L	L6	SP6
	3232P19	●	32	32	170	32	16	40					
4040S19	●	40	40	250	40	20	40						

Applicable insert
Wendeschneidplatten

Application Anwendung	Finishing Schlichten	Semi-Finishing Mittlere Bearbeitung	Roughing Schruppen	Heavy Duty Schwerzerspannung	Cast iron machining Grauguss Bearbeit.	PCBN · PCD PCBN · PKD
insert shape Schneidplattenform	DF  A59	PM  A60	DR  A62 Double-side	HDR  A64	 A65	 A120
	EF  A59	DM  A61	DR  A62 Single-side			
	SF  A60	EM  A61	ER  A63 Double-side			
		NM  A62	ER  A63 Single-side			
Type · Typ	PSDNN**F / H09	SN**0903**	SN**0903**		SN**0903**	
	PSDNN**K / M / P12	SN**1204**	SN**1204**	SN**1204**	SN**1204**	SN**1204**
	PSDNN**M / P15	SN**1506**	SN**1506**	SN**1506**	SN**1506**	
	PSDNN**P / S19		SN**1906**	SN**1906**	SN**1906**	

Turning · Drehen

External turning tools · Drehwerkzeuge zur Außenbearbeitung

SN** Toolholder · Halter

P-Clamping · P-Halter



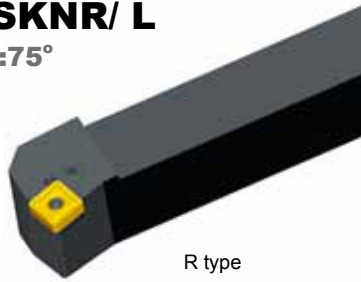

PSKNR/ L

Kr:75°

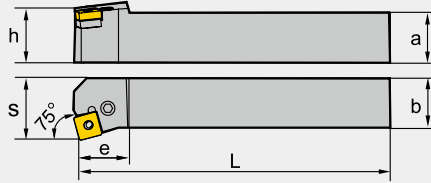















R type
Rechtsausführung



Type · Typ		Stock Lager		Dimension (mm) Abmessung						Screw Schraube	Shim Unterlage	Wrench Schlüssel	Lever Kniehebel	Shim pin Rohrstift
		R	L	a	b	L	h	s	e					
PSKNR/ L	1616H09	●	●	16	16	100	16	20	17	LEM6×13.4A	S09AP	WH25L	L3	SP10
	2020K09	●	●	20	20	125	20	25	20					
	2020K12	●	●	20	20	125	20	25	26	LEM8×21	S12AP	WH30L	L4	SP4
	2525M12	●	●	25	25	150	25	32	26					
	3232P12	●	●	32	32	170	32	40	26	LEM8×25	S15AP	WH30L	L5	SP5
	2525M15	●	●	25	25	150	25	32	32					
	3232P15	●	●	32	32	170	32	40	32	LEM10×27	S19AP	WH40L	L6	SP6
	3232P19	●	●	32	32	170	32	40	36					
4040S19	●	●	40	40	250	40	50	40						

Applicable insert
Wendeschneidplatten

Application Anwendung	Finishing Schlichten	Semi-Finishing Mittlere Bearbeitung	Roughing Schruppen	Heavy Duty Schwerzerspanung	Cast iron machining Grauguss Bearbeit.	PCBN · PCD PCBN · PKD
insert shape Schneidplattenform	DF  A59	PM  A60	DR  A62	HDR  A64	 A65	 A120
	EF  A59	DM  A61	DR  A62			
	SF  A60	EM  A61	ER  A63			
		NM  A62	ER  A63			
Type · Typ	PSKNR/ L**H / K09	SN**0903**	SN**0903**		SN**0903**	
	PSKNR/ L**K / M / P12	SN**1204**	SN**1204**	SN**1204**	SN**1204**	SN**1204**
	PSKNR/ L**M / P15	SN**1506**	SN**1506**	SN**1506**	SN**1506**	
	PSKNR/ L**P / S19		SN**1906**	SN**1906**	SN**1906**	

● ex stock · ab Lager ○ on demand · Anfrage

SN** Toolholder · Halter

P-Clamping · P-Halter



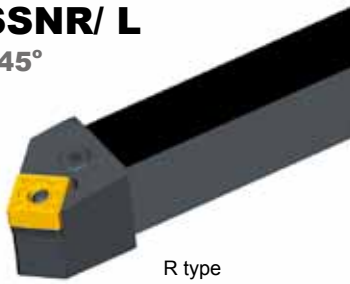

PSSNR/ L

Kr:45°

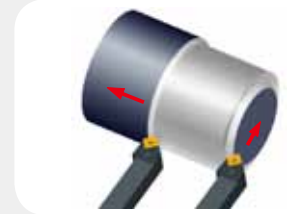
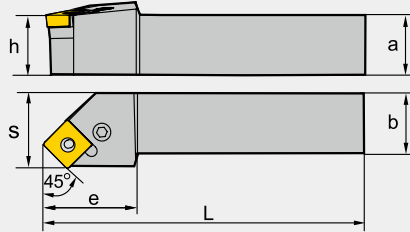















R type
Rechtsausführung



Type · Typ		Stock Lager		Dimension (mm) Abmessung						Screw Schraube	Shim Unterlage	Wrench Schlüssel	Lever Kniehebel	Shim pin Rohrstift
		R	L	a	b	L	h	s	e					
PSSNR/ L	1616H09	●	●	16	16	100	16	20	25	LEM6×13.4A	S09AP	WH25L	L3	SP10
	2020K12	●	●	20	20	125	20	25	30					
	2525M12	●	●	25	25	150	25	32	30	LEM8×21	S12AP	WH30L	L4	SP4
	3232P12	●	●	32	32	170	32	40	40					
	2525M15	●	●	25	25	150	25	32	30	LEM8×25	S15AP	WH30L	L5	SP5
	3232P15	●	●	32	32	170	32	40	40					
	3232P19	●	●	32	32	170	32	40	40	LEM10×27	S19AP	WH40L	L6	SP6
	4040S19	●	●	40	40	250	40	50	50					
	4040S2507	●	●	40	40	250	40	50	50	LEM12×36A	S25AP	WH50L	L8	SP8
4040S2509	●	●	40	40	250	40	50	50	S25AP-09					

Applicable insert
Wendeschneidplatten

Application Anwendung	Finishing Schlichten	Semi-Finishing Mittlere Bearbeitung	Roughing Schruppen	Heavy Duty Schwerzerspanung	Cast iron machining Grauguss Bearbeit.	PCBN · PCD PCBN · PKD
insert shape Schneidplattenform	DF  A59	PM  A60	DR Double-side  A62	HDR  A64	 A65	 A120
	EF  A59	DM  A61	DR Single-side  A62			
	SF  A60	EM  A61	ER Double-side  A63			
		NM  A62	ER Single-side  A63			
PSSNR/ L**H09	SN**0903**	SN**0903**	SN**0903**		SN**0903**	
PSSNR/ L**K / M / P12	SN**1204**	SN**1204**	SN**1204**	SN**1204**	SN**1204**	SN**1204**
PSSNR/ L**M / P15	SN**1506**	SN**1506**	SN**1506**	SN**1506**	SN**1506**	
PSSNR/ L**P / S19		SN**1906**	SN**1906**	SN**1906**	SN**1906**	
PSSNR/ L**S2507			SN**2507**	SN**2507**		
PSSNR/ L**S2509			SN**2509**	SN**2509**		

Turning · Drehen

External turning tools · Drehwerkzeugen zur Außenbearbeitung

TN** Toolholder · Halter

P-Clamping · P-Halter

PTFNR/ L

Kr:90°

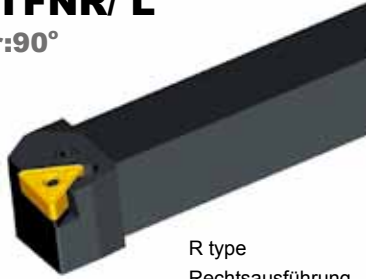



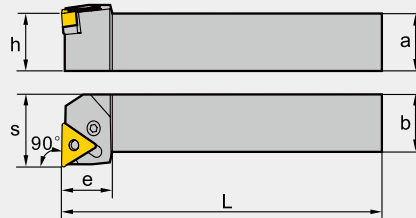









R type
Rechtsausführung



Type · Typ		Stock Lager		Dimension (mm) Abmessung						Screw Schraube	Shim Unterlage	Wrench Schlüssel	Lever Kniehebel	Shim pin Rohrstift
		R	L	a	b	L	h	s	e					
PTFNR/ L	1616H16	●	●	16	16	100	16	20	20	LEM6×13.4A	T16AP	WH25L	L3	SP3
	2020K16	●	●	20	20	125	20	25	20					
	2525M16	●	●	25	25	150	25	32	20					
	2525M22	●	●	25	25	150	25	32	25	LEM8×21	T22AP	WH30L	L4	SP4
	3232P22	●	●	32	32	170	32	40	25					
	3232P27	●	●	32	32	170	32	40	34	LEM8×25	T27AP	WH30L	L5	SP5
4040S27	●	●	40	40	250	40	50	34						

Applicable insert
Wendeschneidplatten

Application Anwendung	Finishing Schlichten	Semi-Finishing Mittlere Bearbeitung	Roughing Schruppen	Heavy Duty Schwerzerspannung	Cast iron machining Grauguss Bearbeit.	PCBN · PCD PCBN · PKD
insert shape Schneidplattenform	DF  A68	PM  A69	DR  A70	HDR  A72	 A73	 A121
	WG Wiper inserts  A68	DM  A69	DR  A71			
	SF  A68	EM  A70	ER  A71			
	EF  A68					
Typ	PTFNR/ L**H / K / M16	TN**1604**	TN**1604**	TN**1604**	TN**1604**	TN**1604**
Typ	PTFNR/ L**M / P22	TN**2204**	TN**2204**	TN**2204**	TN**2204**	TN**2204**
Typ	PTFNR/ L**P / S27			TN**2706**	TN**2706**	TN**2706**

● ex stock · ab Lager ○ on demand · Anfrage

TN** Toolholder · Halter

P-Clamping · P-Halter

PTTNR/ L

Kr:60°

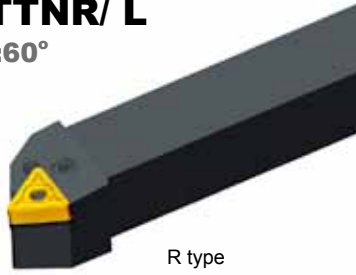



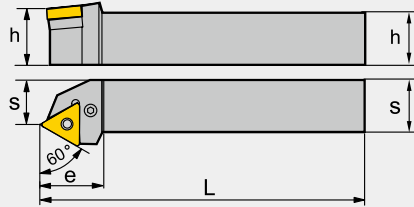









R type
Rechtsausführung



Type · Typ		Stock Lager		Dimension (mm) Abmessung						Screw Schraube	Shim Unterlage	Wrench Schlüssel	Lever Kniehebel	Shim pin Rohrstift
		R	L	a	b	L	h	s	e					
PTTNR/ L	1616H16	●	●	16	16	100	16	13	25	LEM6×13.4A	T16AP	WH25L	L3	SP3
	2020K16	●	●	20	20	125	20	17	25					
	2525M22	●	●	25	25	150	20	22	32	LEM8×21	T22AP	WH30L	L4	SP4

Applicable insert
Wendeschneidplatten

Application Anwendung	Finishing Schlichten	Semi-Finishing Mittlere Bearbeitung	Roughing Schruppen	Heavy Duty Schwerzerspannung	Cast iron machining Grauguss Bearbeit.	PCBN · PCD PCBN · PKD
insert shape Schneidplattenform	DF  A68	PM  A69	DR  A70	HDR  A72	 A73	 A121
	SF  A68	DM  A69	DR  A71			
	EF  A68	EM  A70	ER  A71			
Type	PTTNR / L**H / K16	TN**1604**	TN**1604**	TN**1604**	TN**1604**	TN**1604**
Type	PTTNR / L**M22	TN**2204**	TN**2204**	TN**2204**	TN**2204**	TN**2204**

Turning · Drehen

External turning tools · Drehwerkzeugen zur Außenbearbeitung

TN** Toolholder · Halter

P-Clamping · P-Halter

PTGNR/ L

Kr:90°

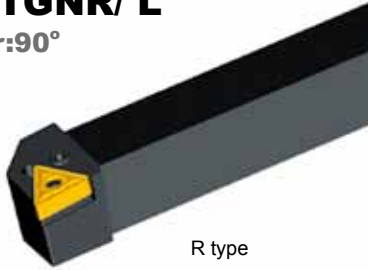



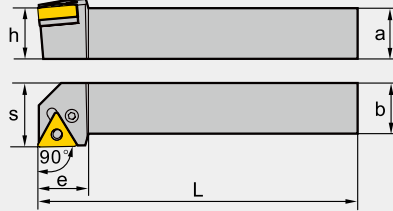









R type
Rechtsausführung



Type · Typ		Stock Lager		Dimension (mm) Abmessung					Screw Schraube	Shim Unterlage	Wrench Schlüssel	Lever Kniehebel	Shim pin Rohrstift	
		R	L	a	b	L	h	s						e
PTGNR/ L	1010E11			10	10	70	10	14	16	LEM5×9B	—	WH20L	L2	—
	1212F11			12	12	80	12	16	14					
	1616H11	●	●	16	16	100	16	20	18					
	2020K11	●	●	20	20	125	20	25	19					
	2525M11	●	●	25	25	150	25	32	20					
	1616H16	●	●	16	16	100	16	20	20					
	2020K16	●	●	20	20	125	20	25	20	LEM6×13.4A	T16AP	WH25L	L3	SP3
	2525M16	●	●	25	25	150	25	32	20					
	3232P16	●	●	32	32	170	32	40	20					
	2525M22	●	●	25	25	150	25	32	28	LEM8×21	T22AP	WH30L	L4	SP4
	3232P22	●	●	32	32	170	32	40	28					
	3232P27	●	●	32	32	170	32	40	33	LEM8×25	T27AP	WH30L	L5	SP5
4040S27	●	●	40	40	250	40	50	33						

Applicable insert
Wendeschneidplatten

Application Anwendung	Finishing Schlichten	Semi-Finishing Mittlere Bearbeitung	Roughing Schruppen	Heavy Duty Schwerzerspanung	Cast iron machining Grauguss Bearbeit.	PCBN · PCD PCBN · PKD
insert shape Schneidplattenform	DF  A68	PM  A69	DR  A70 Double-side	HDR  A72	 A73 Flat	 A121 Flat
	WG  A68 Wiper inserts	DM  A69	DR  A71			
	SF  A68	EM  A70	ER  A71			
	EF  A68					
Type · Typ	PTGNR/L**E / F / H / K / M11	TN**1103**	TN**1103**		TN**1103**	
	PTGNR/L**H / K / M16	TN**1604**	TN**1604**	TN**1604**	TN**1604**	TN**1604**
	PTGNR /L**M / P22	TN**2204**	TN**2204**	TN**2204**	TN**2204**	TN**2204**
	PTGNR/L**P / S27		TN**2706**	TN**2706**	TN**2706**	

● ex stock · ab Lager ○ on demand · Anfrage

WN** Toolholder · Halter

P-Clamping · P-Halter

PWLNR/ L

Kr:95°

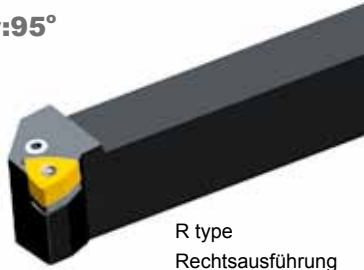

R type
Rechtsausführung

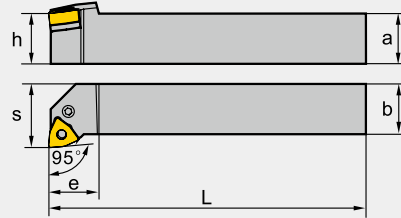

Type · Typ		Stock Lager		Dimension (mm) Abmessung						Screw Schraube	Shim Unterlage	Wrench Schlüssel	Lever Kniehebel	Shim pin Rohrstift
		R	L	a	b	L	h	s	e					
PWLNR/ L	1616H06	●	●	16	16	100	16	20	20	LEM6×13.4A	W06AP	WH25L	L3	SP3
	2020K06	●	●	20	20	125	20	25	20					
	2525M06	●	●	25	25	150	25	32	20					
	2020K08	●	●	20	20	125	20	25	26	LEM8×21	W08AP	WH30L	L4	SP4
	2525M08	●	●	25	25	150	25	32	26					

Applicable insert
Wendeschneidplatten

Application Anwendung	Finishing Schichten	Semi-Finishing Mittlere Bearbeitung	Roughing Schruppen	Cast iron machining Grauguss Bearbeit.	
insert shape Schneidplattenform	DF A76	PM A78	DR Double-side A79	Flat A79	
	WG Wiper inserts A76	DM A78			
	SF A77	EM A78			
	EF A77	NM A79			
	NF A77				
Type · Typ	PWLNR/ L**H / K / M06	WN**0604**	WN**0604**	WN**0604**	WN**0604**
	PWLNR/ L**K / M08	WN**0804**	WN**0804**	WN**0804**	WN**0804**

Turning · Drehen

External turning tools · Drehwerkzeugen zur Außenbearbeitung

CN** Toolholder · Halter

M-Clamping · M-Halter

MCBNR/ L

Kr:75°

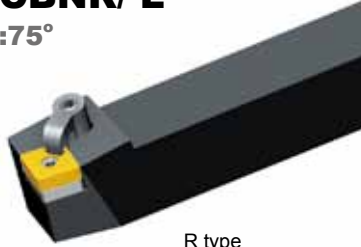

R type
Rechtsausführung

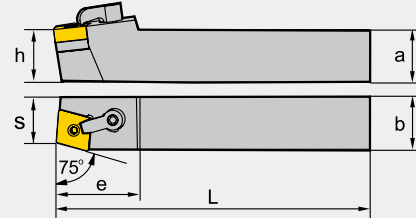

Type · Typ		Stock Lager		Dimension (mm) Abmessung						Clamping screw Schraube	Shim Unterlage	Wrench Schlüssel	Clamp Pratze	Clamping stud Passstift
		R	L	a	b	L	h	s	e					
MCBNR/ L	2020K12	●	○	20	20	125	20	17	32	DM6×25				
	2525M12	●	●	25	25	150	20	22	32	DM6×30	C12BM	WH30L	C1RD	TM6×17
	3225P12	●	●	32	25	170	32	22	32					
	2525M16	○	○	25	25	150	25	22	40	DM6×30	C16BM	WH30L	C2RD	TM8×21
	3232P16	●	●	32	32	170	32	27	40					
	3232P19	○	○	32	32	170	32	27	45					
	4040R19	○	○	40	40	200	40	35	45	DM8×30X	C19BM	WH40L	C5RD	TM10×21

Applicable insert
Wendeschneidplatten

Application Anwendung	Finishing Schichten	Semi-Finishing Mittlere Bearbeitung	Roughing Schruppen	Heavy Duty Schwerzerspannung	Cast iron machining Grauguss Bearbeit.		
insert shape Schneidplattenform	DF A46	PM A47	DR A49	HDR A50	Flat A51		
	SF A46	DM A48	DR A50				
	EF A46	EM A48	ER A50				
	NF A47	NM A49	ER A50				
Type · Typ	MCBNR/ L**K / M / P12		CN**1204**	CN**1204**	CN**1204**	CN**1204**	CN**1204**
	MCBNR/ L**M / P16		CN**1606**	CN**1606**	CN**1606**	CN**1606**	CN**1606**
	MCBNR/ L**P / R19		CN**1906**	CN**1906**	CN**1906**	CN**1906**	CN**1906**

● ex stock · ab Lager ○ on demand · Anfrage

CN** Toolholder · Halter

M-Clamping · M-Halter

MCLNR/ L

Kr:95°

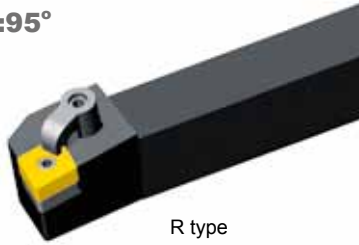

R type
Rechtsausführung

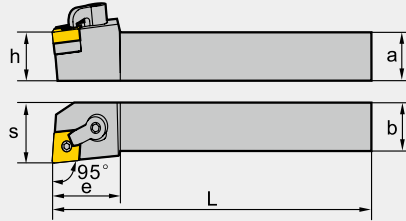

Type · Typ		Stock Lager		Dimension (mm) Abmessung						Clamping screw Schraube	Shim Unterlage	Wrench Schlüssel	Clamp Pratze	Clamping stud Passstift	
		R	L	a	b	L	h	s	e						
MCLNR/ L	2020K12	●	●	20	20	125	20	25	32	DM6×25					
	2525M12	●	●	25	25	150	25	32	32	DM6×30	C12BM	WH30L	C1RD	TM6×17	
	3225P12	●	●	32	25	170	32	32	32						
	2525M16	●	●	25	25	150	25	32	38	DM6×30	C16BM	WH30L	C2RD	TM8×21	
	3232P16	●	●	32	32	170	32	40	38						
	3232P19	●	●	32	32	170	32	40	45	DM8×30X	C19BM	WH40L	C5RD	TM10×21	
	4040R19	○	○	40	40	200	40	50	45						

Applicable insert
Wendeschneidplatten

Application Anwendung	Finishing Schlichten	Semi-Finishing Mittlere Bearbeitung	Roughing Schruppen	Heavy Duty Schwerzerspannung	Cast iron machining Grauguss Bearbeit.	PCBN · PCD PCBN · PKD
insert shape Schneidplattenform	DF A46	PM A47	DR A49	HDR A50	Flat A51	Flat A118
	WG A46	DM A48	DR A50			
	SF A46	EM A48	ER A50			
	EF A46	NM A49	ER A50			
	NF A47					
Type · Typ	MCLNR/ L**K / M / P12	CN**1204**	CN**1204**	CN**1204**	CN**1204**	CN**1204**
	MCLNR/ L**M / P16	CN**1606**	CN**1606**	CN**1606**	CN**1606**	CN**1606**
	MCLNR/ L**P / R19		CN**1906**	CN**1906**	CN**1906**	CN**1906**

Turning · Drehen

External turning tools · Drehwerkzeuge zur Außenbearbeitung

DN** Toolholder · Halter

M-Clamping · M-Halter

MDJNR/ L

Kr:93°

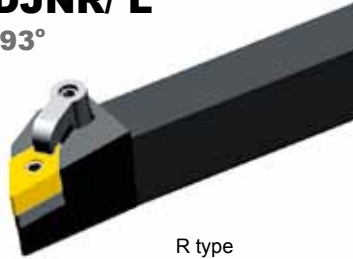



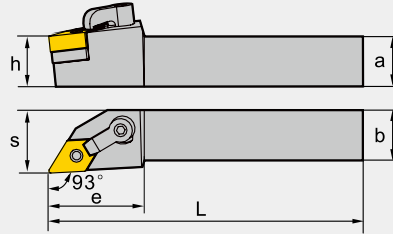













R type
Rechtsausführung



Type · Typ		Stock Lager		Dimension (mm) Abmessung						Clamping screw Schraube	Shim Unterlage	Wrench Schlüssel	Clamp Pratze	Clamping stud Passtift
		R	L	a	b	L	h	s	e					
MDJNR/ L	2020K11	●	●	20	20	125	20	25	32	DM6×25	D11BM	WH20L WH30L	C1RD	TM5×13
	2525M11	●	●	25	25	150	25	32	32	DM6×30				
	3225P11	●	○	32	25	170	32	32	32	DM6×30				
	2020K15	●	●	20	20	125	20	25	38	DM6×25	D15BM	WH30L	C2RD	TM6×19
	2525M15	●	●	25	25	150	25	32	38	DM6×30				
	3225P15	●	●	32	25	170	32	32	38	DM6×30				

Applicable insert
Wendeschneidplatten

Application Anwendung	Finishing Schlichten	Semi-Finishing Mittlere Bearbeitung	Roughing Schruppen	Heavy Duty Schwerzerspannung	Cast iron machining Grauguss Bearbeit.	PCBN · PCD PCBN · PKD
insert shape Schneidplattenform	DF  A53	PM  A55	DR Double-side  A56	HDR  A58	 A58	 A119
	WG  Wiper A53	DM  A55	DR Single-side  A58			
	SF  A53	EM  A56	ER Double-side  A58			
	EF  A54	NM  A56	ER Single-side  A58			
	NF  A54					
Type · Typ	MDJNR / L**K / M / P11	DN**1104**	DN**1104**		DN**1104**	
Type · Typ	MDJNR / L**K / M / P15	DN**1506**	DN**1506**	DN**1506**	DN**1506**	DN**1506**

● ex stock · ab Lager ○ on demand · Anfrage

DN** Toolholder · Halter

M-Clamping · M-Halter





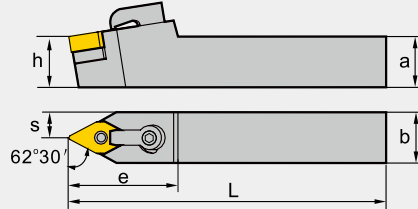
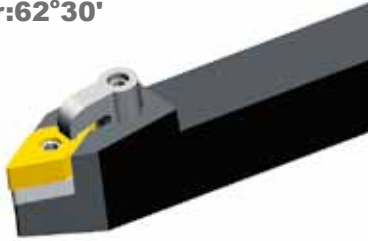









MDPNN

Kr:62°30'



Type · Typ		Stock Lager	Dimension (mm) Abmessung						Clamping screw Schraube	Shim Unterlage	Wrench Schlüssel	Clamp Pratze	Clamping stud Passtift
			a	b	L	h	s	e					
MDPNN	2020K11	●	20	20	125	20	10	35	DM6×25	D11BM	WH20L WH30L	C1RD	TM5×13
	2525M11	●	25	25	150	25	12.5	35					
	3225P11	●	32	25	170	32	12.5	35					
	2020K15	●	20	20	125	20	10	40	DM6×30	D15BM	WH30L	C2RD	TM6×19
	2525M15	●	25	25	150	25	12.5	40					
	3225P15	●	32	25	170	32	12.5	40					

Applicable insert
Wendeschneidplatten

Application Anwendung	Finishing Schlichten	Semi-Finishing Mittlere Bearbeitung	Roughing Schruppen	Heavy Duty Schwerzerspannung	Cast iron machining Grauguss Bearbeit.	PCBN · PCD PCBN · PKD
insert shape Schneidplattenform	DF  A53	PM  A55	DR  A56	HDR  A58	Flat  A58	Flat  A119
	SF  A53	DM  A55	DR  A58			
	EF  A54	EM  A56	ER  A58			
	NF  A54	NM  A56	ER  A58			
Type · Typ	MDPNN**K / M / P11	DN**1104**	DN**1104**			
	MDPNN**K / M / P15	DN**1506**	DN**1506**	DN**1506**	DN**1506**	DN**1506**

Turning · Drehen

External turning tools · Drehwerkzeugen zur Außenbearbeitung

SN** Toolholder · Halter

M-Clamping · M-Halter

MSBNR/ L

Kr:75°

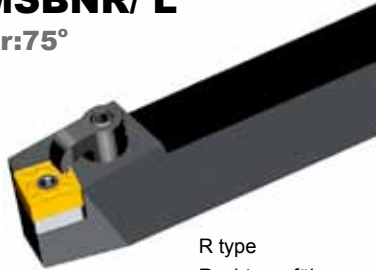



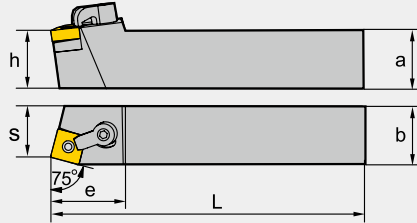











R type
Rechtsausführung



Type · Typ		Stock Lager		Dimension (mm) Abmessung						Clamping screw Schraube	Shim Unterlage	Wrench Schlüssel	Clamp Pratte	Clamping stud Passstift
		R	L	a	b	L	h	s	e					
MSBNR/ L	2020K12	●	●	20	20	125	20	17	32	DM6×25	S12BM	WH30L	C1RD	TM6×17
	2525M12	●	○	25	25	150	25	22	32	DM6×30				
	3225P12	●	○	32	25	170	32	22	32	DM6×30				
	2525M15	●	○	25	25	150	25	22	38	DM6×30	S15BM	WH30L	C2RD	TM8×21
	3232P15	●	○	32	32	170	32	29	38					
	4032R15	●	○	40	32	200	40	27	38	DM8×30X	S19BM	WH40L	C5RD	TM10×21
	3232P19	○	○	32	32	170	32	27	45					
	4040R19	●	○	40	40	200	40	35	45	DM10×35X	S25BM	WH40L WH40L WH50L	C6RD	TM12×29
	4040R25	●	○	40	40	200	40	35	50					
4040S2509	○	○	40	40	250	40	35	50						

Applicable insert
Wendeschneidplatten

Application Anwendung	Finishing Schlichten	Semi-Finishing Mittlere Bearbeitung	Roughing Schruppen	Heavy Duty Schwerzerspannung	Cast iron machining Grauguss Bearbeit.	PCBN · PCD PCBN · PKD	
insert shape Schneidplattenform	DF  A59	PM  A60	DR Double-side  A62	HDR  A64	Flat  A65	Flat  A120	
	EF  A59	DM  A61	DR Single-side  A62				
	SF  A60	EM  A61	ER Double-side  A63				
		NM  A62	ER Single-side  A63				
	MSBNR / L**K / M / P12	SN**1204**	SN**1204**	SN**1204**	SN**1204**	SN**1204**	SN**1204**
	MSBNR / L**M / P / R15	SN**1506**	SN**1506**	SN**1506**	SN**1506**	SN**1506**	SN**1506**
MSBNR / L**P / R19		SN**1906**	SN**1906**	SN**1906**	SN**1906**	SN**1906**	
MSBNR / L**R / S2509			SN**2509**	SN**2509**			

● ex stock · ab Lager ○ on demand · Anfrage

SN** Toolholder · Halter

M-Clamping · M-Halter

MSRNR/ L

Kr:75°

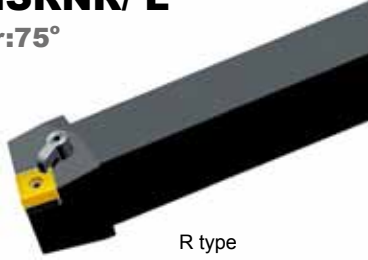

R type
Rechtsausführung

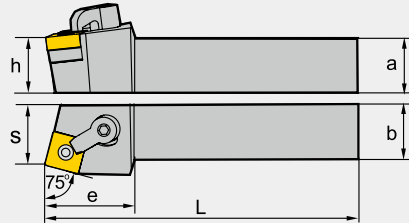

Type · Typ		Stock Lager		Dimension (mm) Abmessung						Clamping screw Schraube	Shim Unterlage	Wrench Schlüssel	Clamp Pratte	Clamping stud Passstift
		R	L	a	b	L	h	s	e					
MSRNR/ L	2020K12	●	○	20	20	125	20	22	36	DM6×25	S12BM	WH30L	C1RD	TM6×17
	2525M12	●	○	25	25	150	25	27	36	DM6×30				
	3225P12	●	○	32	25	170	32	27	36	DM6×30				
	2525M15	●	○	25	25	150	25	27	40	DM6×30	S15BM	WH30L	C2RD	TM8×21
	3232P15	●	○	32	32	170	32	35	40					
	4032R15	○	○	40	32	200	40	35	40	DM8×30X	S19BM	WH40L	C5RD	TM10×21
	3232P19	●	○	32	32	170	32	35	45					
	4040R19	○		40	40	200	40	43	45	DM10×35X	S25BM	WH40L WH50L	C6RD	TM12×29
	4040R2509	○	○	40	40	200	40	43	50					
4040S2509	○	○	40	40	250	40	43	50						

Applicable insert
Wendeschneidplatten

Application Anwendung	Finishing Schlichten	Semi-Finishing Mittlere Bearbeitung	Roughing Schruppen	Heavy Duty Schwerzerspannung	Cast iron machining Grauguss Bearbeit.	PCBN · PCD PCBN · PKD
insert shape Schneidplattenform	DF A59	PM A60	DR A62 Double-side	HDR A64	Flat A65	Flat A120
	EF A59	DM A61	DR A62 Single-side			
	SF A60	EM A61	ER A63 Double-side			
		NM A62	ER A63 Single-side			
Type · Typ	MSRNR / L**K / M / P12	SN**1204**	SN**1204**	SN**1204**	SN**1204**	SN**1204**
	MSRNR / L**M / P / R15	SN**1506**	SN**1506**	SN**1506**	SN**1506**	SN**1506**
	MSRNR / L**P / R19		SN**1906**	SN**1906**	SN**1906**	SN**1906**
	MSRNR / L**R / S2509			SN**2509**	SN**2509**	

Turning · Drehen

External turning tools · Drehwerkzeugen zur Außenbearbeitung

SN** Toolholder · Halter

M-Clamping · M-Halter

MSKNR/ L

Kr:75°

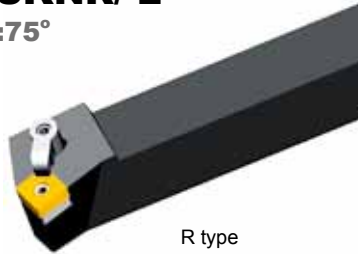

R type
Rechtsausführung

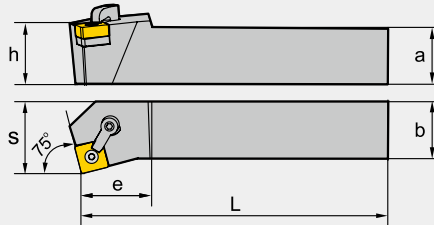

Type · Typ		Stock Lager		Dimension (mm) Abmessung					Clamping screw Schraube	Shim Unterlage	Wrench Schlüssel	Clamp Pratze	Clamping stud Passstift	
		R	L	a	b	L	h	s	e					
MSKNR/ L	2020K12	●	●	20	20	125	20	25	32	DM6×25	S12BM	WH30L	C1RD	TM6×17
	2525M12	●	○	25	25	150	25	32	32	DM6×30				
	3225P12	●	○	32	25	170	32	32	32	DM6×30				
	2525M15	●	○	25	25	150	25	32	28	DM6×30	S15BM	WH30L	C2RD	TM8×21
	3232P15	●	○	32	32	170	32	40	38					
	4032R15	○	○	40	32	200	40	40	38	DM8×30X	S19BM	WH40L	C5RD	TM10×21
	3232P19	●	○	32	32	170	32	40	45					
	4040R19	○	○	40	40	200	40	50	45					
4040S2509	○	○	40	40	250	40	50	50	DM10×35X	S25BM	WH40L WH50L	C6RD	TM12×29	

Applicable insert
Wendeschneidplatten

Application Anwendung	Finishing Schlichten	Semi-Finishing Mittlere Bearbeitung	Roughing Schruppen	Heavy Duty Schwerzerspannung	Cast iron machining Grauguss Bearbeit.	PCBN · PCD PCBN · PKD
insert shape Schneidplattenform	DF A59	PM A60	DR Double-side A62	HDR A64	Flat A65	Flat A120
	EF A59	DM A61	DR Single-side A62			
	SF A60	EM A61	ER Double-side A63			
		NM A62	ER Single-side A63			
Type · Typ	MSKNR / L**K / M / P12	SN**1204**	SN**1204**	SN**1204**	SN**1204**	SN**1204**
	MSKNR / L**M / P / R15	SN**1506**	SN**1506**	SN**1506**	SN**1506**	SN**1506**
	MSKNR / L**P / R19		SN**1906**	SN**1906**	SN**1906**	SN**1906**
	MSKNR / L**S2509			SN**2509**	SN**2509**	

● ex stock · ab Lager ○ on demand · Anfrage

SN** Toolholder · Halter

M-Clamping · M-Halter





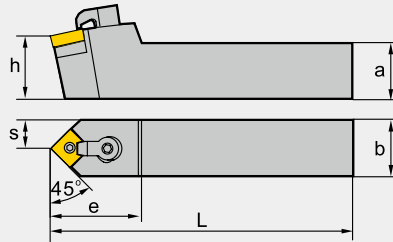









MSDNN

Kr:45°



Type · Typ	Stock Lager	Dimension (mm) Abmessung							Clamping screw Schraube	Shim Unterlage	Wrench Schlüssel	Clamp Pratze	Clamping stud Passtift
		a	b	L	h	s	e						
MSDNN	2020K12	●	20	20	125	20	10	35	DM6×25				
	2525M12	●	25	25	150	25	12.5	35	DM6×30	S12BM	WH30L	C1RD	TM6×17
	3225P12	●	32	25	170	32	12.5	35					
	2525M15	●	25	25	150	25	12.5	42	DM6×30	S15BM	WH30L	C2RD	TM8×21
	3232P15	○	32	32	170	32	16	42					
	4032R15	○	40	32	200	40	16	42					

Applicable insert
Wendeschneidplatten

Application Anwendung	Finishing Schlichten	Semi-Finishing Mittlere Bearbeitung	Roughing Schruppen	Heavy Duty Schwerzerspannung	Cast iron machining Grauguss Bearbeit.	PCBN · PCD PCBN · PKD
insert shape Schneidplattenform	DF  A59	PM  A60	DR Double-side  A62	HDR  A64	Flat  A65	Flat  A120
	EF  A59	DM  A61	DR Single-side  A62			
	SF  A60	EM  A61	ER Double-side  A63			
		NM  A62	ER Single-side  A63			
Type · Typ	MSDNN**K · M · P12	SN**1204**	SN**1204**	SN**1204**	SN**1204**	SN**1204**
	MSDNN**M · P · R15	SN**1506**	SN**1506**	SN**1506**	SN**1506**	SN**1506**

Turning · Drehen

External turning tools · Drehwerkzeuge zur Außenbearbeitung

TN** Toolholder · Halter

M-Clamping · M-Halter

MTGNR/ L

Kr:90°

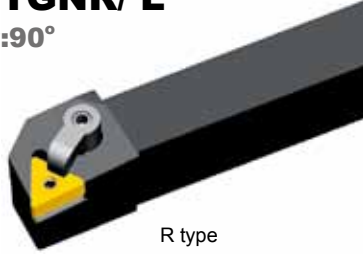



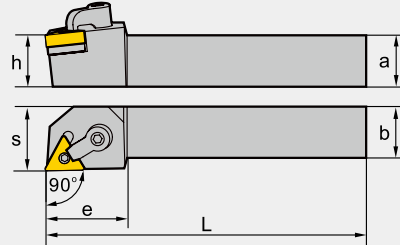









R type
Rechtsausführung



Type · Typ		Stock Lager		Dimension (mm) Abmessung						Clamping screw Schraube	Shim Unterlage	Wrench Schlüssel	Clamp Pratte	Clamping stud Passstift
		R	L	a	b	L	h	s	e					
MTGNR/ L	2020K16	●	○	20	20	125	20	25	33	DM6×25	T16BM	WH20L WH30L	C1RD	TM5×13
	2525M16	●	●	25	25	150	25	32	33	DM6×30				
	3225P16	●	○	32	25	170	32	32	33	DM6×30				
	2525M22	●	○	25	25	150	25	32	35	DM6×30	T22BM	WH30L	C2RD	TM6×17
	3225P22	●	○	32	25	170	32	32	35	DM6×30	T22BM	WH30L	C2RD	TM6×17

Applicable insert
Wendeschneidplatten

Application Anwendung	Finishing Schlichten	Semi-Finishing Mittlere Bearbeitung	Roughing Schruppen	Heavy Duty Schwerzerspannung	Cast iron machining Grauguss Bearbeit.	PCBN · PCD PCBN · PKD
insert shape Schneidplattenform	DF  A68	PM  A69	DR Double -side  A70	HDR  A72	Flat  A73	Flat  A121
	WG Wiper  A68	DM  A69	DR Single- side  A71			
	SF  A68	EM  A70	ER Double- side  A71			
	EF  A68					
Type · Typ	MTGNR / L** K / M / P16	TN**1604**	TN**1604**	TN**1604**	TN**1604**	TN**1604**
	MTGNR / L** M / P22	TN**2204**	TN**2204**	TN**2204**	TN**2204**	TN**2204**

● ex stock · ab Lager ○ on demand · Anfrage

TN** Toolholder · Halter

M-Clamping · M-Halter

MTJNR/ L

Kr:93°

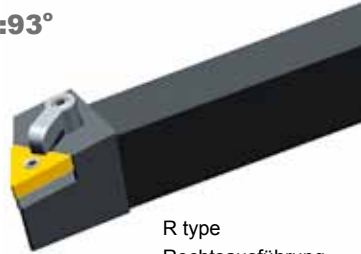



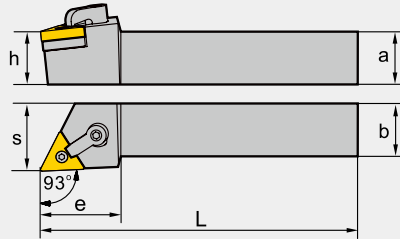









R type
Rechtsausführung



Type · Typ		Stock Lager		Dimension (mm) Abmessung					Clamping screw Schraube	Shim Unterlage	Wrench Schlüssel	Clamp Pratte	Clamping stud Passestift	
		R	L	a	b	L	h	s						e
MTJNR/ L	2020K16	●	●	20	20	125	20	25	32	DM6×25	T16BM	WH20L WH30L	C1RD	TM5×13
	2525M16	●	●	25	25	150	25	32	32	DM6×30				
	3225P16	●	●	32	25	170	32	32	32	DM6×30	T22BM	WH30L	C2RD	TM6×17
	2525M22	●	●	25	25	150	25	32	36					
	3225P22	○	○	32	25	170	32	32	36					

Applicable insert
Wendeschneidplatten

Application Anwendung	Finishing Schlichten	Semi-Finishing Mittlere Bearbeitung	Roughing Schruppen	Heavy Duty Schwerzerspannung	Cast iron machining Grauguss Bearbeit.	PCBN · PCD PCBN · PKD
insert shape Schneidplattenform	DF  A68	PM  A69	DR Double -side  A70	HDR  A72	Flat  A73	Flat  A121
	WG  A68	DM  A69	DR Single- side  A71			
	SF  A68	EM  A70	ER Double- side  A71			
	EF  A68					
Type · Typ	MTJNR / L** K / M / P16	TN**1604**	TN**1604**	TN**1604**	TN**1604**	TN**1604**
	MTJNR / L**M / P22	TN**2204**	TN**2204**	TN**2204**	TN**2204**	TN**2204**

Turning · Drehen

External turning tools · Drehwerkzeuge zur Außenbearbeitung

TN** Toolholder · Halter

M-Clamping · M-Halter

MTFNR/ L

Kr:90°

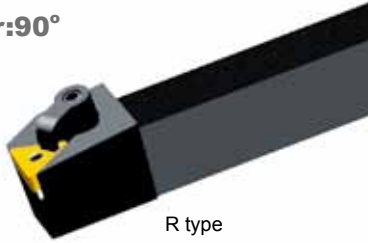



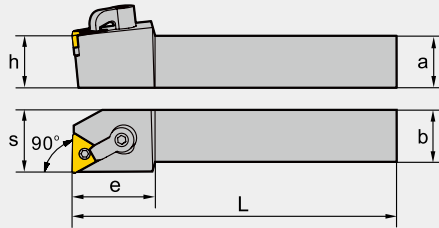









R type
Rechtsausführung



Type · Typ		Stock Lager		Dimension (mm) Abmessung					Clamping screw Schraube	Shim Unterlage	Wrench Schlüssel	Clamp Pratze	Clamping stud Passestift	
		R	L	a	b	L	h	s						e
MTFNR/ L	2020K16	●	●	20	20	125	20	25	32	DM6×25	T16BM	WH20L WH30L	C1RD	TM5×13
	2525M16	●	○	25	25	150	25	32	32	DM6×30				
	3225P16	●	○	32	25	170	32	32	32	DM6×30	T22BM	WH30L	C2RD	TM6×17
	2525M22	●	○	25	25	150	25	32	36					
	3225P22	●	○	32	25	170	32	32	36					

Applicable insert
Wendeschneidplatten

Application Anwendung	Finishing Schlichten	Semi-Finishing Mittlere Bearbeitung	Roughing Schruppen	Heavy Duty Schwerzerspannung	Cast iron machining Grauguss Bearbeit.	PCBN · PCD PCBN · PKD
insert shape Schneidplattenform	DF  A68	PM  A69	DR Double-side  A70	HDR  A72	Flat  A73	Flat  A121
	WG Wiper  A68	DM  A69	DR Single-side  A71			
	SF  A68	EM  A70	ER Double-side  A71			
	EF  A68					
Type · Typ	MTFNR / L** K / M / P16	TN**1604**	TN**1604**	TN**1604**	TN**1604**	TN**1604**
	MTFNR / L**M / P22	TN**2204**	TN**2204**	TN**2204**	TN**2204**	TN**2204**

● ex stock · ab Lager ○ on demand · Anfrage

VN** Toolholder · Halter

M-Clamping · M-Halter





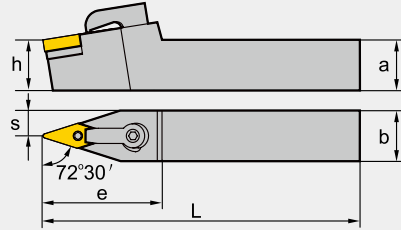



MVVNN

Kr:72°30'

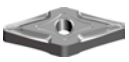

Type · Typ		Stock Lager	Dimension (mm) Abmessung						Clamping screw Schraube	Shim Unterlage	Wrench Schlüssel	Clamp Pratze	Clamping stud Passstift
			a	b	L	h	s	e					
MVVNN	2020K16	●	20	20	125	20	10	45	DM6×25	V16BM	WH20L WH30L	C3RD	TM5×13
	2525M16	●	25	25	150	25	12.5	45	DM6×30				
	3225P16	○	32	25	170	32	12.5	45					
	3232P16	○	32	32	170	32	16	45					

Applicable insert
Wendeschneidplatten

Application Anwendung	Finishing Schlichten	Semi-Finishing Mittlere Bearbeitung	PCBN · PCD PCBN · PKD	
insert shape Schneidplattenform	DF  A74	PM  A75	Flat  A122	
	EF  A74	DM  A75		
	SF  A74	EM  A75		
	NF  A74	NM  A75		
Type · Typ	MVVNN** K / M / P16	VN**1604**	VN**1604**	VN**1604**

Turning · Drehen

External turning tools · Drehwerkzeugen zur Außenbearbeitung

VN** Toolholder · Halter

M-Clamping · M-Halter

MVJNR/ L

Kr:93°

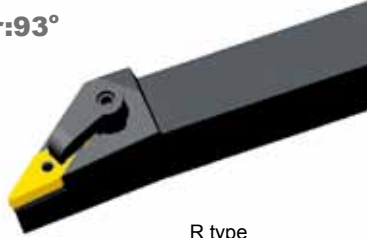

R type
Rechtsausführung

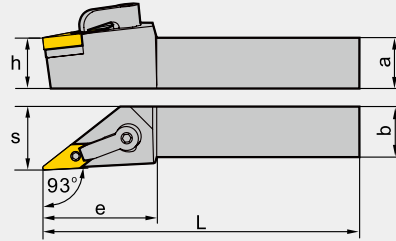

Type · Typ		Stock Lager		Dimension (mm) Abmessung						Clamping screw Schraube	Shim Unterlage	Wrench Schlüssel	Clamp Pratze	Clamping stud Passstift
		R	L	a	b	L	h	s	e					
MVJNR/ L	2020K16	●	●	20	20	125	20	25	45	DM6×25	V16BM	WH20L WH30L	C3RD	TM5×13
	2525M16	●	●	25	25	150	25	32	45					
	3225P16	○	○	32	25	170	32	32	45	DM6×30				
	3232P16	○	●	32	32	170	32	40	45					

Applicable insert
Wendeschneidplatten

Application Anwendung	Finishing Schlichten	Semi-Finishing Mittlere Bearbeitung	PCBN · PCD PCBN · PKD
insert shape Schneidplattenform	DF A74	PM A75	Flat A122
	EF A74	DM A75	
	SF A74	EM A75	
	NF A74	NM A75	
Type · Typ MVJNR / L** K / M / P16	VN**1604**	VN**1604**	VN**1604**

● ex stock · ab Lager ○ on demand · Anfrage

WN** Toolholder · Halter

M-Clamping · M-Halter

MWLNLR/ L

Kr:95°

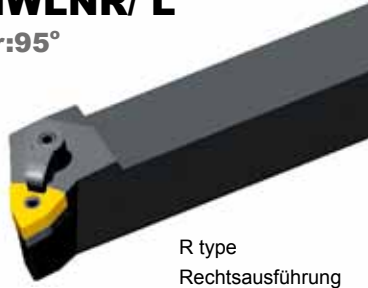



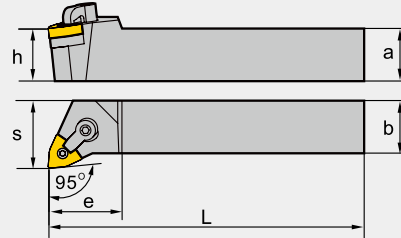







R type
Rechtsausführung



Type · Typ		Stock Lager		Dimension (mm) Abmessung						Clamping screw Schraube	Shim Unterlage	Wrench Schlüssel	Clamp Pratte	Clamping stud Passtift
		R	L	a	b	L	h	s	e					
MWLNLR/ L	2020K06	●	●	20	20	125	20	25	30	DM6×25	W06BM	WH20L WH30L	C1RD	TM5×13
	2525M06	●	●	25	25	150	25	32	30					
	2020K08	●	●	20	20	125	20	25	30					
	2525M08	●	●	25	25	150	25	32	35	DM6×30	W08BM	WH30L	C1RD	TM6×17
	3525P08	○	○	32	25	170	32	32	35					
	3232P08	●	●	32	32	170	32	40	35					

Applicable insert
Wendeschneidplatten

Application Anwendung	Finishing Schlichten	Semi-Finishing Mittlere Bearbeitung	Roughing Schruppen	Cast iron machining Grauguss Bearbeit.
insert shape Schneidplattenform	DF  A76	PM  A78	DR Double -side  A79	Flat  A79
	WG Wiper  A76	DM  A78		
	SF  A77	EM  A78		
	EF  A77	NM  A79		
	NF  A77			
	MWLNLR/ L**K / M06	WN**0604**	WN**0604**	WN**0604**
MWLNLR/ L**K / M / P08	WN**0804**	WN**0804**	WN**0804**	WN**0804**

Turning · Drehen

External turning tools · Drehwerkzeuge zur Außenbearbeitung

RN** Toolholder · Halter

M-Clamping · M-Halter

MRGNR/ L

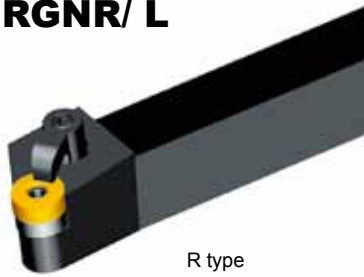

R type
Rechtsausführung

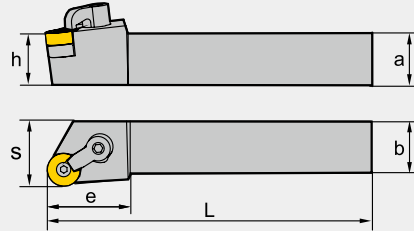

Type · Typ	Stock Lager	Dimension (mm) Abmessung							Application inserts Wendeschneid- platten	Clamping Screw Schraube	Shim Unterlage	Wrench Schlüssel	Clamp Pratze	Clamping stud Passstift
		R	L	a	b	L	h	s						
MRGNR/ L														
	○	○	20	20	125	20	25	32	RN**1204** A80	DM6×25	R12BM	WH30L	C1RD	TM6×17
	○	○	25	25	150	25	32	32		DM6×30				
	○	○	32	25	170	32	32	32						
	○	○	32	32	170	32	40	32						

RN** Toolholder · Halter

M-Clamping · M-Halter

MRDNN

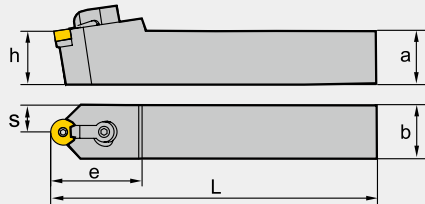

Type · Typ	Stock Lager	Dimension (mm) Abmessung							Application inserts Wendeschneid- platten	Clamping screw Schraube	Shim Unterlage	Wrench Schlüssel	Clamp Pratze	Clamping stud Passstift
		a	b	L	h	s	e							
MRDNN														
	○	○	20	20	125	20	10	35	RN**1204** A80	DM6×25	R12BM	WH30L	C1RD	TM6×17
	○	○	25	25	150	25	12.5	35		DM6×30				
	○	○	32	25	170	32	12.5	35						
	○	○	32	32	170	32	16	35						

● ex stock · ab Lager ○ on demand · Anfrage

CC** Toolholder · Halter

S-Clamping · S-Halter

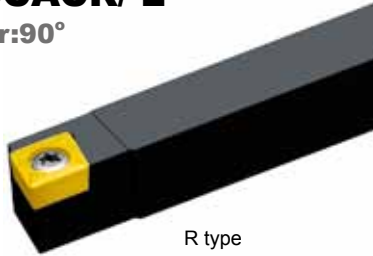

SCACR/ L

Kr:90°



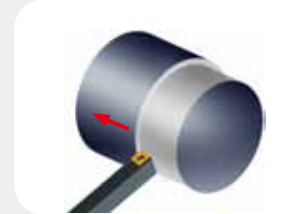
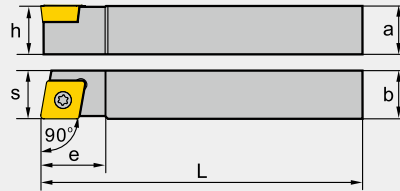







R type
Rechtsausführung



Type · Typ		Stock Lager		Dimension (mm) Abmessung						Screw Schraube	Wrench Schlüssel		
		R	L	a	b	L	h	s	e				
SCACR/ L	1010E06	●	●	10	10	70	10	10.5	10	I60M2.5×6.5	WT07IP		
	1212F09	●	●	12	12	80	12	12.7	16	I60M3.5×8	WT15IP		

Applicable insert
Wendeschneidplatten

Application Anwendung		Extra Finishing Feinbearbeitung	Finishing Schlichten	Semi-finishing Mittlere Bearbeit.	Roughing Schruppen	Al machining Alu Bearbeitung	Cast iron machining Grauguss Bearbeit.	PCBN/PCD inserts/WSP
insert shape Schneidplattenform	SF  A84	HF  A84	HM  A85	HR  A86	LH  A86	 A86	 A123	
		EF  A85	EM  A85					
Type · Typ	SCACR/ L**E06	CC**0602**	CC**0602**	CC**0602**	CC**0602**	CCGX 0602**	CC** 0602**	CC** 0602**
	SCACR/ L**F09	CC**09T3**	CC**09T3**	CC**09T3**	CC**09T3**	CCGX 09T3**	CC** 09T3**	CC** 09T3**

Turning · Drehen

External turning tools · Drehwerkzeugen zur Außenbearbeitung

CC** Toolholder · Halter

S-Clamping · S-Halter

SCLCR/ L

Kr:95°

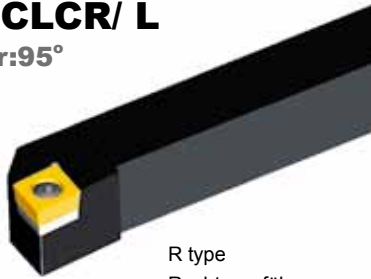



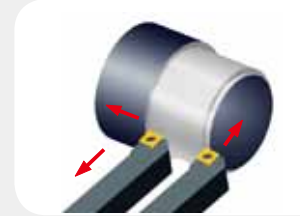
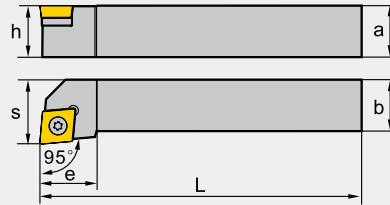





R type
Rechtsausführung



Type · Typ		Stock Lager		Dimension (mm) Abmessung						Screw Schraube	Shim Unterlage	Shim Screw, Unterlage Schraube	Wrench Schlüssel
		R	L	a	b	L	h	s	e				
SCLCR/ L	0808D06	●	●	08	08	60	08	10	10	I60M2.5×6.5	—	—	WT07IP
	1010E06	●	●	10	10	70	10	12	10				
	1212F09	●	●	12	12	80	12	16	16				
	1616H09	●	●	16	16	100	16	20	16	I60M3.5×8	—	—	WT15IP
	2020K12	●	●	20	20	125	20	25	25				
	2525M12	●	●	25	25	150	25	32	26	I60M4×11X	C12BS	SM6×10XA	WT15IP WH40L
	3225P12	●	●	32	25	170	32	32	26				

Applicable insert
Wendeschneidplatten

Application Anwendung	Extra Finishing Feinbearbeitung	Finishing Schlichten	Semi-finishing Mittlere Bearbeit.	Roughing Schruppen	Al machining Alu Bearbeitung	Cast iron mach. Gusseis. Bearb.	PCBN · PCD PCBN · PKD
insert shape Schneidplattenform	SF  A84	HF  A84	HM  A85	HR  A86	LH  A86	Flat  A86	Flat  A123
		EF  A85	EM  A85				
Type · Typ	SCLCR/ L**D / E06	CC** 0602**	CC** 0602**	CC** 0602**	CC** 0602**	CCGX 0602**	CC** 0602**
	SCLCR / L*F / H09	CC** 09T3**	CC** 09T3**	CC** 09T3**	CC** 09T3**	CCGX 09T3**	CC** 09T3**
Type · Typ	SCLCR / L**K / M / P12		CC** 1204**	CC** 1204**	CC** 1204**	CCGX 1204**	CC** 1204**

● ex stock · ab Lager ○ on demand · Anfrage

DC** Toolholder · Halter

S-Clamping · S-Halter



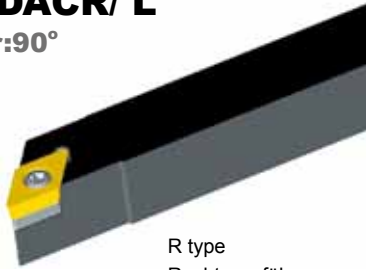

SDACR/ L

Kr:90°

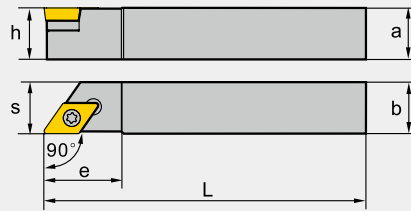







R type
Rechtsausführung



Type · Typ		Stock Lager		Dimension (mm) Abmessung						Screw Schraube	Shim Unterlage	Shim Screw, Unterlage Schraube	Wrench Schlüssel
		R	L	a	b	L	h	s	e				
SDACR/ L	1010E07	●	●	10	10	70	10	10.5	15	I60M2.5×6.5	—	—	WT07IP
	1212F11	●	●	12	12	80	12	12.5	15	I60M3.5×8	—	—	WT15IP
	1616H11	●	●	16	16	100	16	16.7	24	I60M3.5×12	D11BS	SM5×8.65XA	WT15IP WH35L

Applicable insert
Wendeschneidplatten

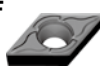
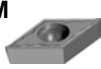
Application Anwendung	Extra Finishing Feinbearbeitung	Finishing Schichten	Semi-finishing Mittlere Bearbeit.	Roughing Schrappen	Al machining Alu Bearbeitung	Cast iron mach. Gusseis. Bearb.	PCBN · PCD PCBN · PKD
insert shape Schneidplattenform	SF  A88	HF  A88	HM  A89	HR  A90	LH  A90	Flat  A90	Flat  A124
		EF  A89	EM  A89				
Type · Typ	SDACR / L**E07	DC** 0702**	DC** 0702**	DC** 0702**	DCGX 0702**	DC**0702**	DC**0702**
	SDACR / L**F / H11	DC** 11T3**	DC** 11T3**	DC** 11T3**	DC** 11T3**	DCGX 11T3**	DC** 11T3**

Turning · Drehen

External turning tools · Drehwerkzeuge zur Außenbearbeitung

DC** Toolholder · Halter

S-Clamping · S-Halter

SDJCR/ L

Kr:93°

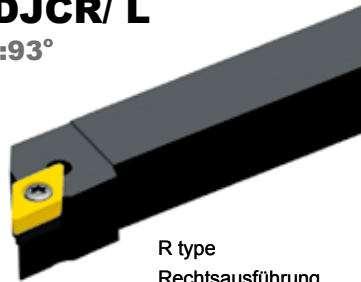



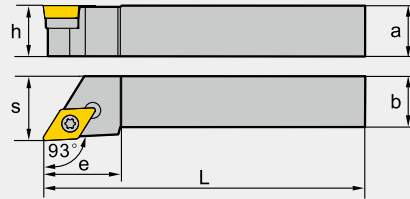





R type
Rechtsausführung

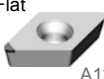

Type · Typ		Stock Lager		Dimension (mm) Abmessung						Screw Schraube	Shim Unterlage	Shim Screw, Unterlage Schraube	Wrench Schlüssel
		R	L	a	b	L	h	s	e				
SDJCR/ L	1010E07	●	●	10	10	70	10	12	15	I60M2.5×6.5	—	—	WT071P
	1212F07	●	●	12	12	80	12	16	15				
	1616H07	●	●	16	16	100	16	20	18				
	1616H11	●	●	16	16	100	16	20	24	I60M3.5×12	D11BS	SM5×8.65XA	WT151P WH35L
	2020K11	●	●	20	20	125	20	25	24				
	2525M11	●	●	25	25	150	25	32	29				
	3225P11	●	●	32	25	170	32	32	29				

Applicable insert
Wendeschneidplatten

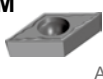
Application Anwendung	Extra Finishing Feinbearbeitung	Finishing Schlichten	Semi-finishing Mittlere Bearbeit.	Roughing Schruppen	Al machining Alu Bearbeitung	Cast iron mach. Gusseis. Bearb.	PCBN · PCD PCBN · PKD	
insert shape Schneidplattenform	SF  A88	HF  A88	HM  A89	HR  A90	LH  A90	Flat  A90	Flat  A124	
		EF  A89	EM  A89					
Type · Typ	SDJCR / L**E / F / H07	DC**0702**	DC** 0702**	DC**0702**		DCGX 0702**	DC** 0702**	DC** 0702**
	SDJCR / L**H / K / M / P11	DC** 11T3**	DC** 11T3**	DC**11T3**	DC**11T3**	DCGX 11T3**	DC** 11T3**	DC** 11T3**

● ex stock · ab Lager ○ on demand · Anfrage

DC** Toolholder · Halter

S-Clamping · S-Halter





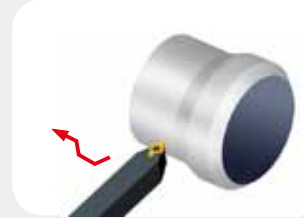
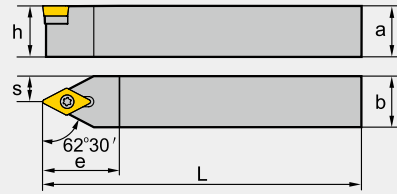
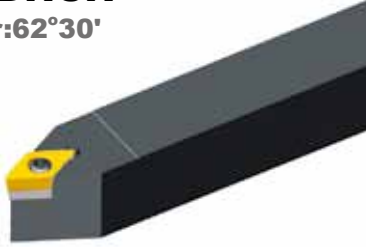



SDNCN

Kr:62°30'



Type · Typ		Stock Lager	Dimension (mm) Abmessung						Screw Schraube	Shim Unterlage	Shim Screw, Unterlage Schraube	Wrench Schlüssel
			a	b	L	h	s	e				
SDNCN	1010E07	●	10	10	70	10	5	20	I60M2.5×6.5	—	—	WT07IP
	1212F07	●	12	12	80	12	6	20				
	1212H11	●	12	12	100	12	6	30				
	1616H11	●	16	16	100	16	8	30	I60M3.5×12	D11BS	SM5×8.65XA	WT15IP WH35L
	2020K11	●	20	20	125	20	10	30				
	2525M11	●	25	25	150	25	12.5	30				

Applicable insert
Wendeschneidplatten

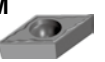
Application Anwendung	Extra Finishing Feinbearbeitung	Finishing Schlichten	Semi-finishing Mittlere Bearbeit.	Roughing Schruppen	Al machining Alu Bearbeitung	Cast iron mach. Gusseis. Bearb.	PCBN · PCD PCBN · PKD
insert shape Schneidplattenform	SF  A88	HF  A88	HM  A89	HR  A90	LH  A90	Flat  A90	Flat  A124
		EF  A89	EM  A89				
Type · Typ	SDNCN**E / F07	DC**0702**	DC** 0702**	DC**0702**		DCGX 0702**	DC** 0702**
	SDNCN**H / K / M11	DC** 11T3**	DC** 11T3**	DC**11T3**	DC**11T3**	DCGX 11T3**	DC** 11T3**

Turning · Drehen

External turning tools · Drehwerkzeuge zur Außenbearbeitung

VB** Toolholder · Halter

S-Clamping · S-Halter

SVJBR/ L

Kr:93°

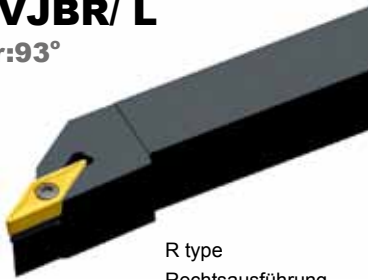



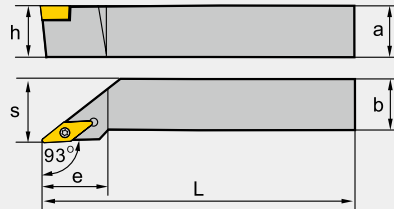



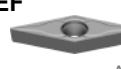

R type
Rechtsausführung

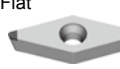

Type · Typ		Stock Lager		Dimension (mm) Abmessung						Screw Schraube	Shim Unterlage	Shim Screw, Unterlage Schraube	Wrench Schlüssel
		R	L	a	b	L	h	s	e				
SVJBR/ L	1212F11	●	●	12	12	80	12	16	27	I60M2.5×6.5	—	—	WT07IP
	1616H11	●	●	16	16	100	16	20	27				
	2020K11	●	●	20	20	125	20	25	27				
	2525M11	●	●	25	25	150	25	32	27				
	1616H16	●	●	16	16	100	16	20	36	I60M3.5×12	V16BS	SM5×8.65XA	WT15IP WH35L
	2020K16	●	●	20	20	125	20	25	41				
	2525M16	●	●	25	25	150	25	32	41				
	3225P16	●	●	32	25	170	32	32	41				

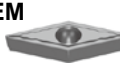
Applicable insert
Wendeschneidplatten

Application Anwendung	Extra Finishing Feinbearbeitung	Finishing Schichten	Semi-finishing Mittlere Bearbeit.	Roughing Schruppen	Cast iron mach. Gusseis. Bearb.	PCBN · PCD PCBN · PKD
insert shape Schneidplattenform	SF  A108	EF  A108	HM  A109	HR  A109	Flat  A109	Flat  A126
		HF  A108	EM  A109			
		NF  A108				
Type · Typ	SVJBR/ L**F/ H/ K/ M11	VB**1102**	VB**1102**	VB**1102**		
	SVJBR/ L**H/ K/ M/ P16		VB**1604**	VB**1604**	VB**1604**	VB**1604**

● ex stock · ab Lager ○ on demand · Anfrage

VB** Toolholder · Halter

S-Clamping · S-Halter



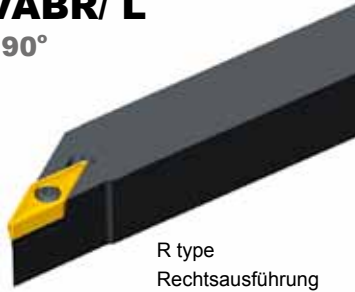

SVABR/ L

Kr:90°

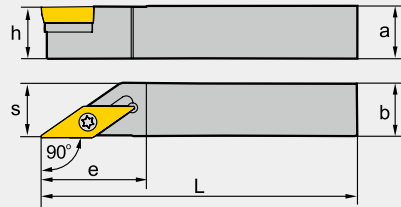









R type
Rechtsausführung



Type · Typ		Stock Lager		Dimension (mm) Abmessung					Screw Schraube	Shim Unterlage	Shim Screw, Unterlage Schraube	Wrench Schlüssel	
		R	L	a	b	L	h	s	e				
SVABR/ L	1010F11			10	10	80	10			I60M2.5×6.5	—	—	WT07IP
	1616H16	●	●	16	16	100	16	16.5	28	I60M3.5×12	V16BS	SM5×8.65XA	WT15IP WH35L
	2020K16	●	●	20	20	125	20	20.5	28				
	2525M16	●	●	25	25	150	25	25.5	28				

Applicable insert
Wendeschneidplatten

Application Anwendung	Extra Finishing Feinbearbeitung	Finishing Schlichten	Semi-finishing Mittlere Bearbeit.	Roughing Schruppen	Cast iron mach. Gusseis. Bearb.	PCBN · PCD PCBN · PKD
insert shape Schneidplattenform	SF  A108	EF  A108	HM  A109	HR  A109	Flat  A109	Flat  A126
		HF  A108	EM  A109			
		NF  A108				
Type · Typ	SVABR / L**F11	VB**1102**	VB**1102**	VB**1102**		
	SVABR / L**H / K / M16		VB**1604**	VB**1604**	VB**1604**	VB**1604**

Turning · Drehen

External turning tools · Drehwerkzeuge zur Außenbearbeitung

VB** Toolholder · Halter

S-Clamping · S-Halter





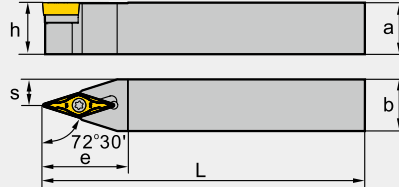
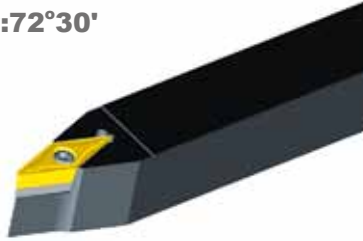



SVVBN

Kr:72°30'



Type · Typ		Stock Lager	Dimension (mm) Abmessung					Screw Schraube	Shim Unterlage	Shim Screw, Unterlage Schraube	Wrench Schlüssel	
			a	b	L	h	s					e
SVVBN	1212F11	●	12	12	80	12	6	27	I60M2.5×6.5	—	—	WT07IP
	1616H11	●	16	16	100	16	8	27				
	2020K11	●	20	20	125	20	10	30				
	1616H16	●	16	16	100	16	8	33	I60M3.5×12	V16BS	SM5×8.65XA	WT15IP WH35L
	2020K16	●	20	20	125	20	10	33				
	2525M16	●	25	25	150	25	12.5	38				

Applicable insert
Wendeschneidplatten

Application Anwendung	Extra Finishing Feinbearbeitung	Finishing Schlichten	Semi-finishing Mittlere Bearbeit.	Roughing Schruppen	Cast iron mach. Gusseis. Bearb.	PCBN · PCD PCBN · PKD
insert shape Schneidplattenform	SF  A108	EF  A108	HM  A109	HR  A109	Flat  A109	Flat  A126
		HF  A108	EM  A109			
		NF  A108				
Type · Typ	SVVBN**F / H / K11	VB**1102**	VB**1102**	VB**1102**		
	SVVBN**H / K / M16		VB**1604**	VB**1604**	VB**1604**	VB**1604**

● ex stock · ab Lager ○ on demand · Anfrage

VC** Toolholder · Halter

S-Clamping · S-Halter



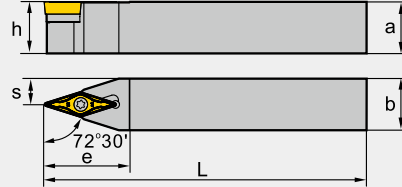
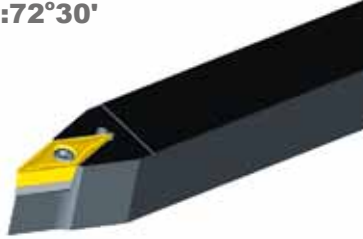

SVVCN

Kr:72°30'



Type · Typ		Stock Lager	Dimension (mm) Abmessung					Screw Schraube	Shim Unterlage	Shim Screw, Unterlage Schraube	Wrench Schlüssel	
			a	b	L	h	s					e
SVVCN	1212F11	●	12	12	80	12	6	27	I60M2.5×6.5	—	—	WT071P
	1212M11	●	12	12	150	12	6	27				
	1616H11	●	16	16	100	16	8	27				
	2020K11	●	20	20	125	20	10	30				
	2525M11	●	25	25	150	25	12.5	38				
	1616H16	●	16	16	100	16	8	33	I60M3.5×12	V16BSC	SM5×8.65XA	WT151P WH35L
	2020K16	●	20	20	125	20	10	33				
	2525M16	●	25	25	150	25	12.5	38				

Applicable insert
Wendeschneidplatten

Application Anwendung	Extra Finishing Feinbearbeitung	Finishing Schlichten	Al machining Alu Bearbeitung	PCBN · PCD PCBN · PKD
insert shape Schneidplattenform	SF  A106	HF  A106	LH  A107	Flat  A126
		NF  A106		

Type · Typ	SVVCN**F / H / K / M11	VC**1103**	VC**1103**	VCGX1103**	
	SVVCN**H / K / M16		VC**1604**	VCGX1604**	VC**1604**

Turning · Drehen

External turning tools · Drehwerkzeuge zur Außenbearbeitung

VC** Toolholder · Halter

S-Clamping · S-Halter

SVJCR/ L

Kr:93°

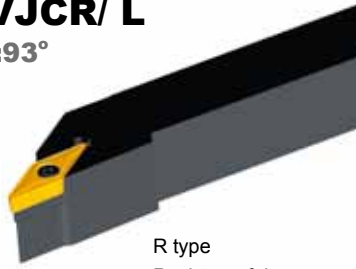

R type
Rechtsausführung

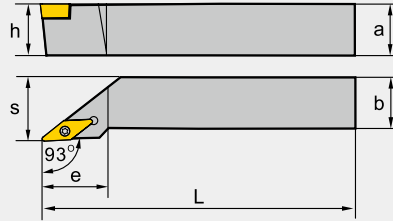

Type · Typ		Stock Lager		Dimension (mm) Abmessung						Screw Schraube	Shim Unterlage	Shim Screw, Unterlage Schraube	Wrench Schlüssel
		R	L	a	b	L	h	s	e				
SVJCR/ L	1010E11			10	10	70	10	12	22	I60M2.5×6.5	—	—	WT071P
	1212F11	●	●	12	12	80	12	16	27				
	1616H11	●	●	16	16	100	16	20	27				
	2020K11	●	●	20	20	125	20	25	27				
	2525M11	●	●	25	25	150	25	32	27				
	1616H16	●	●	16	16	100	16	20	36	I60M3.5×12	V16BSC	SM5×8.65XA	WT151P WH35L
	2020K16	●	●	20	20	125	20	25	41				
	2020M16	●	●	20	20	150	20	25	41				
	2525M16	●	●	25	25	150	20	32	41				
	3225P16			32	25	170	32	32	41				

Applicable insert
Wendeschneidplatten

Application Anwendung	Extra Finishing Feinbearbeitung	Finishing Schlichten	Al machining Alu Bearbeitung	PCBN · PCD PCBN · PKD
insert shape Schneidplattenform	SF A106	HF A106	LH A107	Flat A126
		NF A106		
Type · Typ	SVJCR/ L**E/ F/ H/ K/ M11	VC**1103**	VC**1103**	VCGX1103**
	SVJCR/ L**H/ K/ M/ P16		VC**1604**	VCGX1604**
				VC**1604**

● ex stock · ab Lager ○ on demand · Anfrage

SC** Toolholder · Halter

S-Clamping · S-Halter

SSBCR/ L

Kr:75°



R type
Rechtsausführung

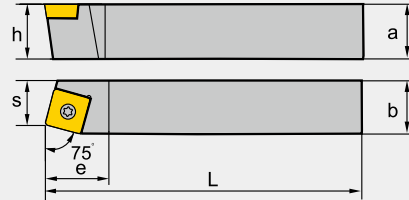

Type · Typ		Stock Lager		Dimension (mm) Abmessung					Screw Schraube	Shim Unterlage	Shim Screw, Unterlage Schraube	Wrench Schlüssel	
		R	L	a	b	L	h	s					e
SSBCR/ L	1212F09	●	●	12	12	80	12	11	16	I60M3.5×8	—	—	WT15IP
	1616H09	●	●	16	16	100	16	13	16	I60M3.5×8	S09BS	SM5×8.65XA	WT15IP WH35L
	2020K12	●	●	20	20	125	20	17	25	I60M4×11X	S12BS	SM6×10XA	WT15IP WH40L

SC** Toolholder · Halter

S-Clamping · S-Halter





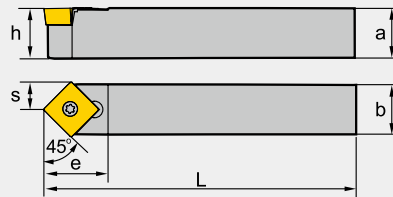
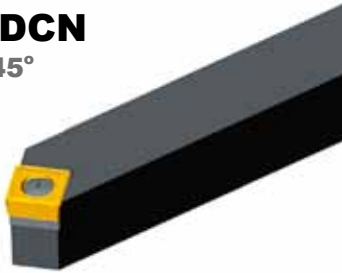

SSDCN

Kr:45°



Type · Typ		Stock Lager	Dimension (mm) Abmessung					Screw Schraube	Shim Unterlage	Shim Screw, Unterlage Schraube	Wrench Schlüssel	
			a	b	L	h	s					e
SSDCN	1212F09	●	12	12	80	12	6	15.5	I60M3.5×8	—	—	WT15IP
	1616H09	●	16	16	100	16	8	15.5	I60M3.5×12	S09BS	SM5×8.65XA	WT15IP WH35L

Applicable insert Wendeschneidplatten

Application Anwendung	Extra Finishing Feinbearbeitung	Finishing Schichten	Semi-finishing Mittlere Bearbeit.	Al machining Alu Bearbeitung	Cast iron machining Gusseisen Bearbeit.
insert shape Schneidplattenform	HF  A94	HM  A94	HR  A95	LH  A95	Flat  A95
	EF  A94	EM  A94			
Type · Typ	SSBCR / L**F / H09	SC**09T3**	SC**09T3**	SC**09T3**	SCGx09T3**
	SSBCR / L**K12		SC**1204**	SC**1204**	SCGx1204**
	SSDCN**F / H09	SC**09T3**	SC**09T3**	SC**09T3**	SCGx09T3**

Turning · Drehen

External turning tools · Drehwerkzeuge zur Außenbearbeitung

SC** Toolholder · Halter

S-Clamping · S-Halter

SSKCR/ L

Kr:75°

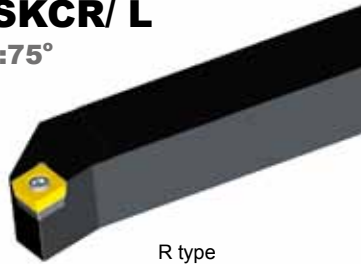

R type
Rechtsausführung

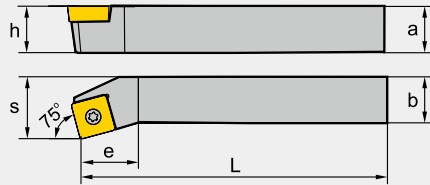

Type · Typ		Stock Lager		Dimension (mm) Abmessung					Screw Schraube	Shim Unterlage	Shim Screw, Unterlage Schraube	Wrench Schlüssel	
		R	L	a	b	L	h	s					e
SSKCR/ L	1616H09	●	●	16	16	100	16	20	13				
										I60M3.5×12	S09BS	SM5×8.65XA	WT15IP WH35L

SSSCR/ L

Kr:45°

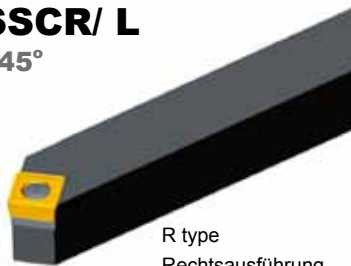

R type
Rechtsausführung

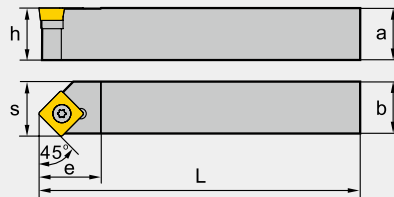

Type · Typ		Stock Lager		Dimension (mm) Abmessung					Screw Schraube	Shim Unterlage	Shim Screw, Unterlage Schraube	Wrench Schlüssel	
		R	L	a	b	L	h	s					e
SSSCR/ L	1616H09	●	●	16	16	100	16	17	16		—	—	
	2020K12	●	●	20	20	125	20	21	24	I60M4×11X	S12BS	SM6×10XA	WT15IP WH40L

Applicable insert
Wendeschneidplatten

Application Anwendung	Extra Finishing Feinbearbeitung	Finishing Schlichten	Semi-finishing Mittlere Bearbeit.	Al machining Alu Bearbeitung	Cast iron machining Gusseisen Bearbeit.
insert shape Schneidplattenform	HF A94	HM A94	HR A95	LH A95	Flat A95
	EF A94	EM A94			
Type · Typ	SSKCR / L**H09	SC**09T3**	SC**09T3**	SC**09T3**	SCG09T3**
	SSSCR / L**H09	SC**09T3**	SC**09T3**	SC**09T3**	SCG09T3**
	SSSCR / L**K12		SC**1204**	SC**1204**	SCG1204**

● ex stock · ab Lager ○ on demand · Anfrage

TC** Toolholder · Halter

S-Clamping · S-Halter

STACR/ L

Kr:90°



R type
Rechtsausführung

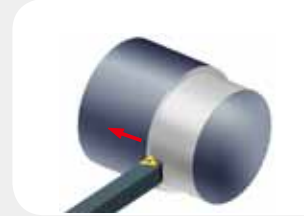
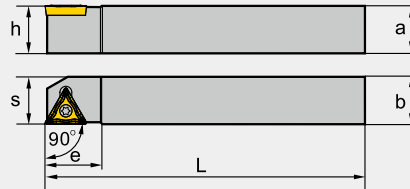

Type · Typ		Stock Lager		Dimension (mm) Abmessung						Screw Schraube	Wrench Schlüssel		
		R	L	a	b	L	h	s	e				
STACR/ L	1212F11	●	●	12	12	80	12	12.5	14	I60M2.5×6.5	WT07IP		

STFCR/ L

Kr:91°

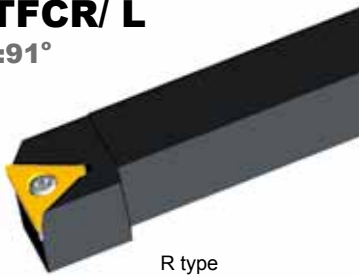



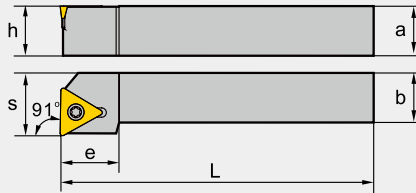



R type
Rechtsausführung

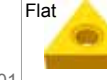
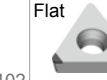

Type · Typ		Stock Lager		Dimension (mm) Abmessung						Screw Schraube	Shim Unterlage	Shim Screw, Unterlage Schraube	Wrench Schlüssel
		R	L	a	b	L	h	s	e				
STFCR/ L	1212F11	●	●	12	12	80	12	16	14	I60M2.5×6.5	—	—	WT07IP
	1616H11	●	●	16	16	100	16	20	14				
	1616H16	●	●	16	16	100	16	20	19	I60M3.5×12	T16BS	SM5×8.65XA	WT15IP WH35L
	2020K16	●	●	20	20	125	20	25	19				

Applicable insert Wendeschneidplatten

Application Anwendung	Extra Finishing Feinbearbeitung	Finishing Schlichten	Semi-finishing Mittlere Bearbeit.	Roughing Schruppen	Al machining Alu Bearbeitung	Cast iron machining	PCBN/PCD inserts/WSP
insert shape Schneidplattenform	SF  A98	HF  A99	HM  A101	HR  A101	LH  A101	Flat  A102	Flat  A125
		EF  A100	EM  A100				
Type · Typ	STACR/ L**F11	TC**1102**	TC**1102**	TC**1102**	TC**1102**	TCGX1102**	TC**1102**
	STFCR/ L**F/ H11	TC**1102**	TC**1102**	TC**1102**	TC**1102**	TCGX1102**	TC**1102**
	STFCR/ L**H/ K16		TC**16T3**	TC**16T3**	TC**16T3**	TCGX16T3**	TC**16T3**

Turning · Drehen

External turning tools · Drehwerkzeugen zur Außenbearbeitung

TC** Toolholder · Halter

S-Clamping · S-Halter

STGCR/ L

Kr:91°





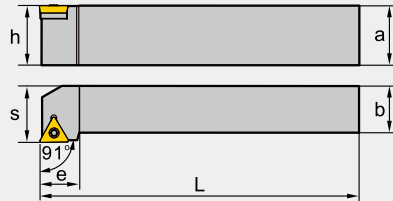





R type
Rechtsausführung



Type · Typ		Stock Lager		Dimension (mm) Abmessung						Screw Schraube	Shim Unterlage	Shim Screw, Unterlage Schraube	Wrench Schlüssel
		R	L	a	b	L	h	s	e				
STGCR/ L	0808D09	●	●	08	08	60	8	10	11	I60M2.2×5.5	—	—	WT06IP
	1010E09	●	●	10	10	70	10	12	11				
	1212F11	●	●	12	12	80	12	16	14				
	1616H11	●	●	16	16	100	16	20	16	I60M2.5×6.5	—	—	WT07IP
	2020K16	●	●	20	20	125	20	25	21				
	2525M16	●	●	25	25	150	25	32	21	I60M3.5×12	T16BS	SM5×8.65XA	WT15IP WH35L

Applicable insert
Wendeschneidplatten

Application Anwendung	Extra Finishing Feinbearbeitung	Finishing Schlichten	Semi-finishing Mittlere Bearbeit.	Roughing Schruppen	Al machining Alu Bearbeitung	Cast iron machining	PCBN/PCD inserts/WSP
insert shape Schneidplattenform	SF  A98	HF  A99	HM  A101	HR  A101	LH  A101	Flat  A102	Flat  A125
		EF  A100	EM  A100				
Type · Typ	STGCR / L**D / E09	TC**0902**	TC**0902**	TC**0902**	TC**0902**	TCGX0902**	TC**0902**
	STGCR / L**F / H11	TC**1102**	TC**1102**	TC**1102**	TC**1102**	TCGX1102**	TC**1102**
	STGCR / L**K / M16		TC**16T3**	TC**16T3**	TC**16T3**	TCGX16T3**	TC**16T3**

● ex stock · ab Lager ○ on demand · Anfrage

TC** Toolholder · Halter

S-Clamping · S-Halter



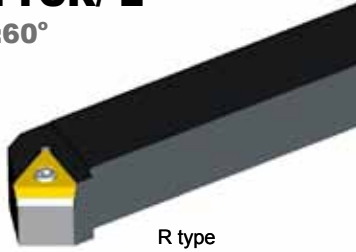

STTCR/ L

Kr:60°

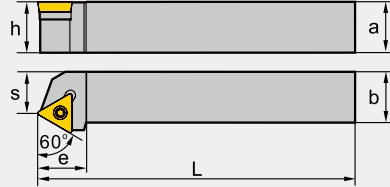









R type
Rechtsausführung



Type · Typ		Stock Lager		Dimension (mm) Abmessung						Screw Schraube	Shim Unterlage	Shim Screw, Unterlage Schraube	Wrench Schlüssel
		R	L	a	b	L	h	s	e				
STTCR/ L	1616H11	●	●	16	16	100	16	13	14	I60M2.5×6.5	—	—	WT07IP
	1616H16	●	●	16	16	100	16	13	19	I60M3.5×12	T16BS	SM5×8.65XA	WT15IP
	2020K16	●	●	20	20	125	20	17	19				WH35L

Applicable insert
Wendeschneidplatten

Application Anwendung	Extra Finishing Feinbearbeitung	Finishing Schlichten	Semi-finishing Mittlere Bearbeit.	Roughing Schruppen	Al machining Alu Bearbeitung	Cast iron machining	PCBN/PCD inserts/WSP
insert shape Schneidplattenform	SF  A98	HF  A99	HM  A101	HF  A101	LH  A101	Flat  A102	Flat  A125
		EF  A100	EM  A100				
Type · Typ	STTCR/ L**H11	TC**1102**	TC**1102**	TC**1102**	TC**1102**	TCGX1102**	TC**1102**
	STTCR/ L**H/ K16		TC**16T3**	TC**16T3**	TC**16T3**	TCGX16T3**	TC**16T3**

Turning · Drehen

External turning tools · Drehwerkzeugen zur Außenbearbeitung

A

General Turning · Allgemeine Drehbearbeitung

WC** Toolholder · Halter

S-Clamping · S-Halter

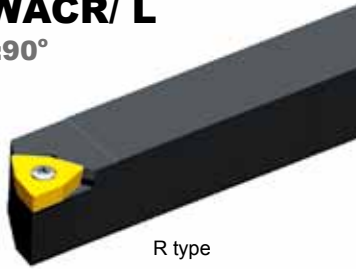

SWACR/ L

Kr:90°

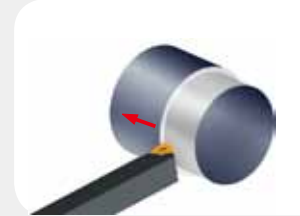

R type
Rechtsausführung



Type · Typ		Stock Lager		Dimension (mm) Abmessung						Screw Schraube	Wrench Schlüssel		
		R	L	a	b	L	h	s	e				
SWACR/ L	1010E04	●	●	10	10	70	10	10.5	10	I60M2.5×6.5	WT07IP		
	1212F04	●	●	12	12	80	12	12.0	14				
	1616H06	●	●	16	16	100	16	16.5	20	I60M3×7	WT10IP		
	2020K08	●	●	20	20	125	20	20.5	24	I60M3.5×12	WT15IP		

Applicable insert
Wendeschneidplatten

Application
Anwendung

Finishing
Schlichten

insert shape
Schneidplattenform

53



A111

Type · Typ	SWACR / L**E / F04	WC*X0402**
	SWACR / L**H06	WC*X06T3**
	SWACR / L**K08	WC*X0804**

● ex stock · ab Lager ○ on demand · Anfrage

RC** Toolholder · Halter



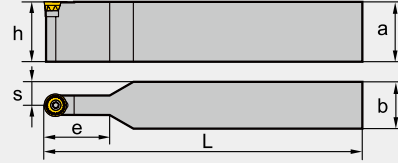

S-Clamping · S-Halter

SRDCN



Type · Typ		Stock Lager	Dimension (mm) Abmessung							Screw Schraube	Shim Unterlage	Shim Screw, Unterlage Schraube	Wrench Schlüssel
			a	b	L	h	s	e					
SRDCN	1616H08	●	16	16	100	16	8	16	I60M3×7	—	—	WT10IP	
	1616H10		16	16	100	16	8	25	I60M3.5×10	—	—	WT15IP	
	2020K10		20	20	125	20	10	25					
	2525M10	●	25	25	150	25	12.5	25	I60M3.5×12	R12BS	SM5×8.65XA	WT15IP WH35L	
	2020K12	●	20	20	125	20	10	35					
	2525M12	●	25	25	150	25	12.5	35					
	3225P12	●	32	25	170	32	12.5	35	I60M4×15X	R16BS	SM6×10XA	WT15IP WH40L	
	3225P16	●	32	25	170	32	12.5	35					
	3232P16	●	32	32	170	32	16	40					
4040S16	●	40	40	250	40	20	50						

Applicable insert
Wendeschneidplatten

Application Anwendung	Semi-Finishing Mittlere Bearbeitung	Roughing Schruppen	Al machining Alu Bearbeitung	Roughing Schruppen
insert shape Schneidplattenform	 A92	 A92	LH  A92	Basic  A93
Type · Typ	SRDCN**H08	RCMT0803MO	RCMT0803MO	RCGX0803MO-LH
	SRDCN**H / K / M10	RCMT10T3 MO	RCMT10T3 MO	RCMT10T3 MO
	SRDCN**K / M / P12	RCMT1204 MO	RCMT1204 MO	RCMT1204 MO
	SRDCN**P / S16	RCMT1606 MO	RCMT1606 MO	RCMT1606 MO

Turning · Drehen

External turning tools · Drehwerkzeuge zur Außenbearbeitung

RC** Toolholder · Halter



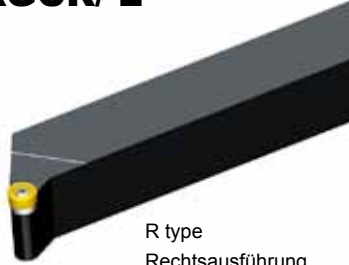

S-Clamping · S-Halter

SRGCR/ L

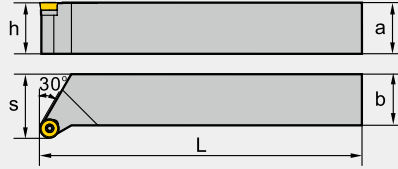





R type
Rechtsausführung



Type · Typ		Stock Lager		Dimension (mm) Abmessung					Screw Schraube	Shim Unterlage	Shim Screw, Unterlage Schraube	Wrench Schlüssel
		R	L	a	b	L	h	s				
SRGCR/ L	1616H08			16	16	100	16	20	I60M3×7	—	—	WT10IP
	1616H10			16	16	100	16	20	I60M3.5×10	—	—	WT15IP
	2020K10	●	●	20	20	125	20	25				
	2525M10	●	●	25	25	100	25	32				
	2020K12	●	●	20	20	125	20	27	I60M3.5×12	R12BS	SM5×8.65XA	WT15IP WH35L
2525M12	●	●	25	25	150	25	32					

Applicable insert
Wendeschneidplatten

Application Anwendung	Semi-Finishing Mittlere Bearbeitung	Roughing Schruppen	Al machining Alu Bearbeitung	Roughing Schruppen	
insert shape Schneidplattenform			LH 	Basic 	
	A92	A92	A92	A93	
Type · Typ	SRGCR / L**H08	RCMT0803MO	RCMT0803MO	RCG0803MO-LH	RCMT0803MO
	SRGCR / L**H / K / M10	RCMT10T3 MO	RCMT10T3 MO		RCMT10T3 MO
	SRGCR / L**K / M12	RCMT1204 MO	RCMT1204 MO		RCMT1204 MO

● ex stock · ab Lager ○ on demand · Anfrage

KNUX** Toolholder · Halter

C-Clamping · C-Halter

CKJNR/ L

Kr:93°



R type
Rechtsausführung

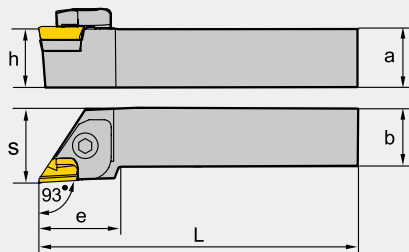

Type · Typ		Stock Lager	Dimension (mm) Abmessung						Application inserts Wendeschneid- platten	Clamp Pratze	Clamp PratzeScrew Schraube	Spring Feder	Clamping stud Passstift	Shim Unterlage	Shim Screw, Unterlage Schraube	Wrench Schlüssel
			a	b	L	h	s	e								
CKJNR	2525M16	●	25	25	150	25	32	32	KNUX1604**R A81	C6R1T	CM6×25A	SPR1 SPR2	P0515	K16CC	SM3×10B	WH20L WH40L
	3232P16	●	32	32	170	32	40	30								
	4040R16	●	40	40	200	40	50	32								
CKJNL	2525M16	●	25	25	150	25	32	32	KNUX1604**L A81	C6L1T	CM6×25A	SPR1 SPR2	P0515	K16CCL	SM3×10B	WH20L WH40L
	3232P16	●	32	32	170	32	40	32								
	4040R16	●	40	40	200	40	50	32								

CKNNR/ L

Kr:63°



R type
Rechtsausführung

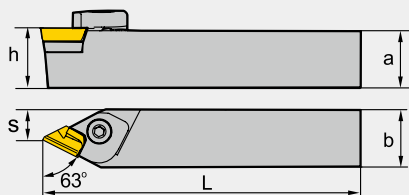

Type · Typ		Stock Lager	Dimension (mm) Abmessung						Application inserts Wendeschneid- platten	Clamp Pratze	Clamp PratzeScrew Schraube	Spring Feder	Clamping stud Passstift	Shim Unterlage	Shim Screw, Unterlage Schraube	Wrench Schlüssel
			a	b	L	h	s	e								
CKNNR	2525M16	○	25	25	150	25	14.3	KNUX1604**R A81	C6R1T	CM6×25A	SPR1 SPR2	P0515	K16CC	SM3×10B	WH20L WH40L	
	3232P16	○	32	32	170	32	16.8									
CKNNL	2525M16	○	25	25	150	25	14.3	KNUX1604**L A81	C6L1T	CM6×25A	SPR1 SPR2	P0515	K16CCL	SM3×10B	WH20L WH40L	
	3232P16	○	32	32	170	32	16.8									

Turning · Drehen

External turning tools · Drehwerkzeugen zur Außenbearbeitung

CN** Toolholder · Halter

C-Clamping · C-Halter

CCLNR/ L

Kr:95°

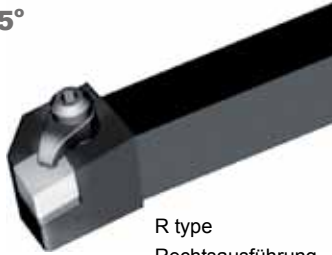

R type
Rechtsausführung

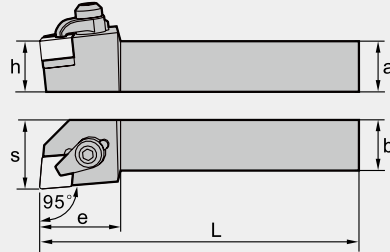

Type · Typ		Stock Lager		Dimension (mm) Abmessung						Application inserts Wendeschneidplatten	Clamp Prätze	Clamp screw Schraube	Wrench Schlüssel	Shim Unterlage	Shim screw Schraube	Spring Feder
		R	L	a	b	L	h	s	e							
CCLNR/ L	2020K12	●	○	20	20	125	20	27	32	CNGN1207** (1204**) A139	C1RC	CM6×30B	WH20L WH40L	C12CC-07 (C12CC-04)	SM3×10B	SPR1
	2525M12	●	●	25	20	100	25	27	36							
	2525M16	○	○	25	25	150	25	32	36	CNGN1606** (1604**) A139	C2RC	CM8×30B	WH30L WH50L	C16CC-06 (16CC-04)	SM4×12B	SPR3
	3225P16	○	○	32	25	170	32	32	36							

TN** Toolholder · Halter

C-Clamping · C-Halter

CTJNR/ L

Kr:93°

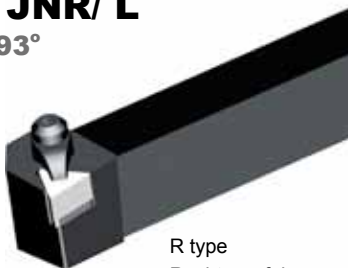

R type
Rechtsausführung

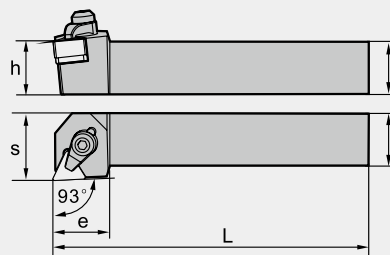

Type · Typ		Stock Lager		Dimension (mm) Abmessung						Application inserts Wendeschneidplatten	Clamp Prätze	Clamp screw Schraube	Wrench Schlüssel	Shim Unterlage	Shim screw Schraube	Spring Feder
		R	L	a	b	L	h	s	e							
CTJNR/ L	2020K16	○	○	20	20	125	20	25	30	TNGN1607** (1604**) A145	C1RC	CM6×30B	WH20L WH40L	T16CC-07 (T16CC-04)	SM3×10B	SPR1
	2525M16	○	○	25	25	150	25	32	30							

● ex stock · ab Lager ○ on demand · Anfrage

TN** Toolholder · Halter

C-Clamping · C-Halter

CTUNR/ L

Kr:93°

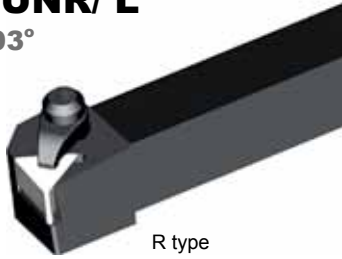

R type
Rechtsausführung

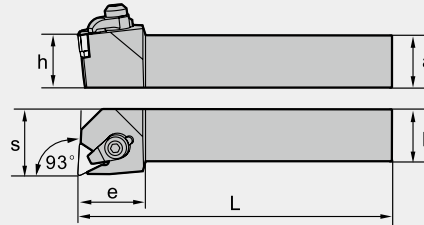

Type · Typ		Stock Lager		Dimension (mm) Abmessung						Application inserts Wendschneidplatten	Clamp Pratze	Clamp screw Schraube	Wrench Schlüssel	Shim Unterlage	Shim screw Schraube	Spring Feder
		R	L	a	b	L	h	s	e							
CTUNR/ L	2020K12			20	20	125	20	25	27	TNGN1607** (1604**) A145	C1RC	CM6×30B	WH20L WH40L	T16CC-07 (T16CC-04)	SM3×10B	SPR1
	2525M16	○	○	25	25	150	25	32	27							

DN** Toolholder · Halter

C-Clamping · C-Halter

CDJNR/ L

Kr:93°

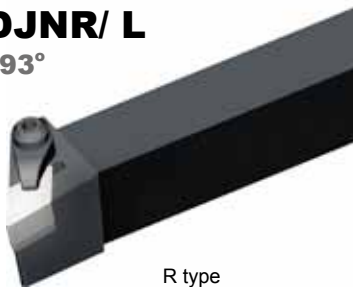

R type
Rechtsausführung

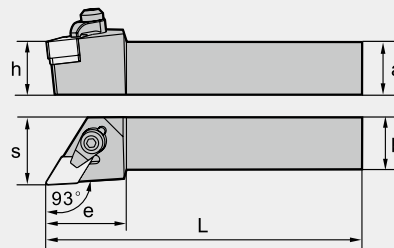

Type · Typ		Stock Lager		Dimension (mm) Abmessung						Application inserts Wendschneidplatten	Clamp Pratze	Clamp screw Schraube	Wrench Schlüssel	Shim Unterlage	Shim screw Schraube	Spring Feder
		R	L	a	b	L	h	s	e							
CDJNR/ L	2525M15	●	●	25	25	150	25	32	32	DNGN1507** (1504**) A141	C1RC	CM6×30B	WH20L WH40L	D15CC-07 (D15CC-04)	SM3×10B	SPR1
	3225P15	○	○	32	25	170	32	32	32							

Turning · Drehen

External turning tools · Drehwerkzeuge zur Außenbearbeitung

SN** Toolholder · Halter

C-Clamping · C-Halter

CSRNR/ L

Kr:75°

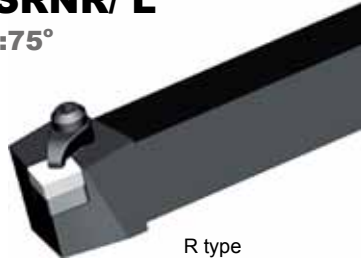

R type
Rechtsausführung

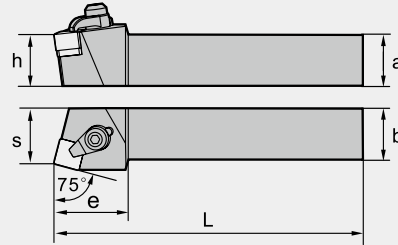

Type · Typ		Stock Lager		Dimension (mm) Abmessung					Application inserts Wendeschneidplatten	Clamp Pratze	Clamp screw Schraube	Wrench Schlüssel	Shim Unterlage	Shim screw Schraube	Spring Feder	
		R	L	a	b	L	h	s								e
CSRNR/ L	2020K12	○	○	20	20	125	20	22	32	SNGN1207** (1204**) A143	C1RC	CM6×30B	WH20L WH40L	S12CC-07 (S12CC-04)	SM3×10B	SPR1
	2525M12	○	○	25	20	100	25	27	32							
	3225P12	○	○	32	25	170	32	27	32	SNGN1507** A143	C2RC	CM8×30B	W030L WH50L	S15CC-07	SM4×12B	SPR3
	3225P15	○	○	32	25	170	32	32	40							
4040R15	○	○	40	40	200	40	43	40								

SN** Toolholder · Halter

C-Clamping · C-Halter

CSKNR/ L

Kr:75°

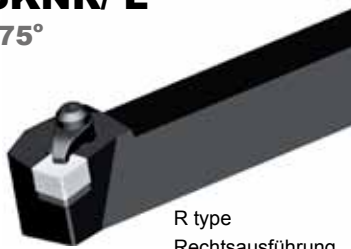

R type
Rechtsausführung

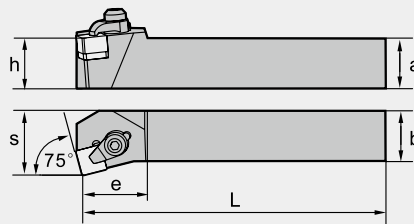

Type · Typ		Stock Lager		Dimension (mm) Abmessung					Application inserts Wendeschneidplatten	Clamp Pratze	Clamp screw Schraube	Wrench Schlüssel	Shim Unterlage	Shim screw Schraube	Spring Feder	
		R	L	a	b	L	h	s								e
CSKNR/ L	2020K12	○	○	20	20	125	20	25	25	SNGN1207** (1204**) A143	C1RC	CM6×30B	WH20L WH40L	S12CC-07 (S12CC-04)	SM3×10B	SPR1
	2525M12	○	○	25	25	170	25	32	25							
	3225P12	○	○	32	25	170	32	32	25	SNGN1507** A143	C2RC	CM8×30B	WH30L WH50L	S15CC-07	SM4×12B	SPR3
	3225P15	○	○	32	25	170	32	32	30							

● ex stock · ab Lager ○ on demand · Anfrage

SN** Toolholder · Halter

C-Clamping · C-Halter

CSDNN

Kr:45°

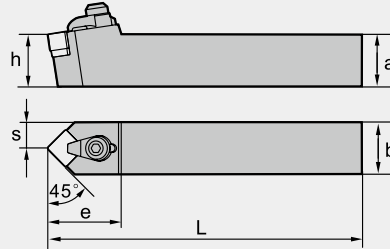

Type · Typ	Stock Lager	Dimension (mm) Abmessung						Application inserts Wendeschneid- platten	Clamp Pratze	Clamp screw Schraube	Wrench Schlüssel	Shim Unterlage	Shim screw Schraube	Spring Feder	
		a	b	L	h	s	e								
CSDNN	2020K12	○	20	20	125	20	10	35	SNGN1207** (1204**) A143	C1RC	CM6×30B	WH20L WH40L	S12CC-07 (S12CC-04)	SM3×10B	SPR1
	2525M12	○	25	25	150	25	12.5	30							
	3225P12	○	32	25	170	32	12.5	35							

RN** Toolholder · Halter

C-Clamping · C-Halter

CRDNN

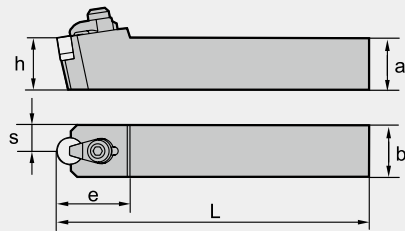

Type · Typ	Stock Lager	Dimension (mm) Abmessung						Application inserts Wendeschneid- platten	Clamp Pratze	Clamp screw Schraube	Wrench Schlüssel	Shim Unterlage	Shim screw Schraube	Spring Feder	
		a	b	L	h	s	e								
CRDNN	2020K12	○	20	20	125	20	10	32	RNGN1207** (1204**) A146	C1RC	CM6×30B	WH20L WH40L	R12CC-07 (R12CC-04)	SM3×10B	SPR1
	2525M12	○	25	25	150	25	12.5	32							
	3225P12	○	32	25	170	32	12.5	32							
	3232P15	○	32	32	170	32	17.5	40	RNGN1507** A146	C2RC	CM8×30B	WH20L WH50L	R15CC-07	SM3×10B	SPR3
	4040R15	○	40	40	200	40	20	40							

Turning · Drehen

External turning tools · Drehwerkzeugen zur Außenbearbeitung

A

General Turning · Allgemeine Drehbearbeitung

CN** Toolholder · Halter

J-Clamping · J-Halter

JCLNR/ L

Kr:95°



R type
Rechtsausführung

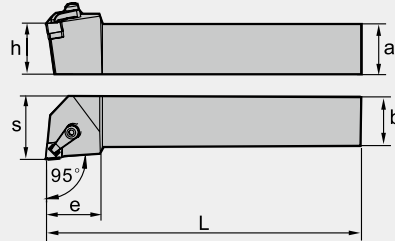

Type · Typ		Stock Lager		Dimension (mm) Abmessung					Application inserts Wendschneidplatten	Clamp Pratze	Clamp screw Schraube	Wrench Schlüssel	Shim Unterlage	Shim screw Schraube	Spring Feder	
		R	L	a	b	L	h	s								e
JCLNR/ L	2020K12	○	○	20	20	125	20	29	32	CNGX1207** A140	C1RJ	CM6×30B	WH20L WH40L	C12CC-07	SM3×10B	SPR1
	2525M12	○	○	25	25	150	25	32	32							

DN** Toolholder · Halter

J-Clamping · J-Halter

JDJNR/ L

Kr:93°

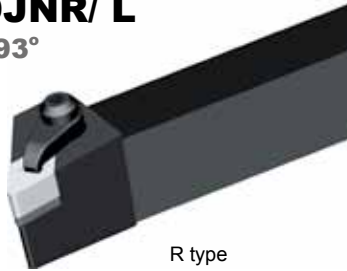

R type
Rechtsausführung

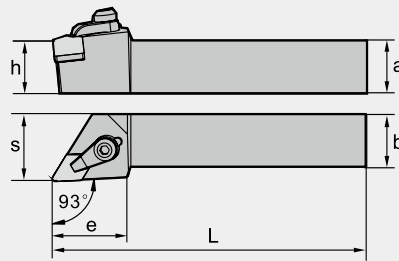

Type · Typ		Stock Lager		Dimension (mm) Abmessung					Application inserts Wendschneidplatten	Clamp Pratze	Clamp screw Schraube	Wrench Schlüssel	Shim Unterlage	Shim screw Schraube	Spring Feder	
		R	L	a	b	L	h	s								e
JDJNR/ L	2525M15	○	○	25	25	150	25	32	38	DNGX1507** A141	C1RJ	CM6×30B	WH20L WH40L	D15CC-07	SM3×10B	SPR1
	3225P15	○	○	32	25	170	32	32	38							

● ex stock · ab Lager ○ on demand · Anfrage

SN** Toolholder · Halter

J-Clamping · J-Halter

JSDNN

Kr:45°

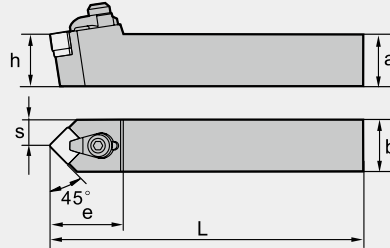

Type · Typ		Stock Lager	Dimension (mm) Abmessung						Application inserts Wendeschneidplatten	Clamp Pratze	Clamp screw Schraube	Wrench Schlüssel	Shim Unterlage	Shim screw Schraube	Spring Feder
			a	b	L	h	s	e							
JSDNN	2020K12	○	20	20	125	20	10	40	SNGX1207** A142	C1RJ	CM6x30B	WH20L WH40L	S12CC-07	SM3x10B	SPR1
	2525M12	○	25	25	150	25	12.5	40							
	3225P12	○	32	25	170	32	12.5	40							

NOTIZEN:

Area with horizontal dotted lines for notes.

A close-up, high-angle photograph of a turning tool tip, likely a carbide insert, mounted on a lathe. The tool is positioned diagonally across the frame, with its sharp cutting edge pointing towards the top right. The background is a solid blue color, which transitions into a lighter blue gradient at the bottom. The tool's surface shows some fine details and a small logo.

Turning · Drehen

Internal Turning Tools · Drehwerkzeuge zur Innenbearbeitung

Turning tool overview · Drehwerkzeuge Übersicht **A213**

Turning tool code key · ISO Kennzeichnung **A214-A215**

**Detailed table of Internal turning tool
Drehwerkzeuge zur Innenbearbeitung** **A216-A253**

Turning toolholders by P type clamping · Drehwerkzeuge / P Klemmung **A216-A227**

Turning toolholders by S type clamping · Drehwerkzeuge / S Klemmung **A228-A240**

Antivibration Tool Holder · Antivibration-Klemmhalter **A241-A248**



Clamping system Klemmsystem	Feature Merkmale	62°30'	75°	85°	90°	91°	93°	93°	95°	107°30'
P	<ul style="list-style-type: none"> min. Ø to be machined = 20mm min. Bearbeitungs Ø = 20mm neg. inserts with good stability and Economy Neg. WSP mit guter Stabilität & Wirtschaftlichkeit 	PDSN A218	PSKN A221		PTFN A222			PDUN A219	PCLN A216	
									PWLN A223	
S	<ul style="list-style-type: none"> min. Ø to be machined = 8,5mm (Screw Clamping) min. Bearbeitungs Ø = 8,5mm (Schraubenklemm.) Inserts with 5°/7°/11° Pos.-WSP mit 5°/7°/11° 		SSKC A229	SDZC A228	SCFC A239	STFC A230	STUP A238	SDUC A227		SDQC A226
								SDUP A237	SCLC A224	SDQP A236
								SVUC A232	SCLC A240	SVQB A233
								SVUB A234	SCLP A235	SVQC A231
Antivibration	<ul style="list-style-type: none"> Antivibrations toolholder (Cemented Carbide) min. Ø to be machined = 8,5mm Inserts with 5°/7°/11° Antivibrations-Klemmhalter (Hartmetall) min. Bearbeitungs Ø = 8,5mm WSP mit 5°/7°/11° 						STUP A245	SDUP A244	SCLP A242	SDQP A243
									SVUC A248	

Turning · Drehen





Internal turning tools Code Key · Drehwerkzeugen zur Innenbearbeitung ISO Kennzeichnung

General Turning · Allgemeine Drehbearbeitung

Type of Shank Schaftausführung		Shank diameter Schaftdurchmesser		Tool length Halterlänge		Clamping System Klemmsystem		Insert shape Plattenform	
code	Type/Typ	code	diameter	code	length				
A	Steel shank+Oil hole Stahlschaft mit Kühlbohrung					P			
C	Carbide shank Hartmetallschaft					M	 Screw clamping Schraub Spannsystem		
E	Carbide shank+Oil hole Hartmetallschaft mit Kühlbohrung					S	 Wedge lock clamping Pratzenkeilklemmung		
S	Steel shank Stahlschaft					C	 Overhead clamping Pratzenklemmung		
X	Special insert application Besondere Anwendung								

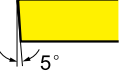
S 16 R - S D U



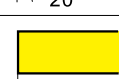
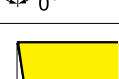

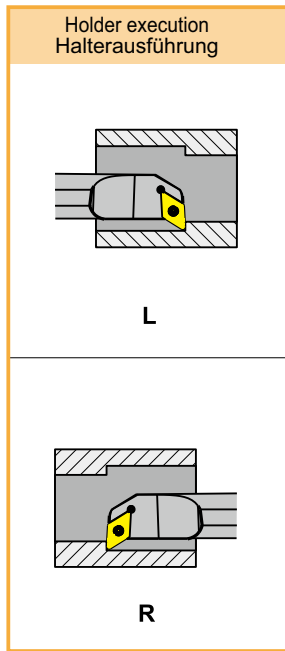
Holder style and lead angle Halteform und Anstellwinkel							
A	B	C	D	E	F	G	H

Clearance angle of major cutting edge Freiwinkel von Hauptschneide	
	B
	C
	D
	E
	N
	P



Manufacture option Herstellungsoptionen	
D	Increase offset f size+1.0mm Aufmaß von F +1mm erhöhen
E	Increase offset f size+2.0mm Aufmaß von F +2mm erhöhen
R	Round shank Rundschaft
W	Wedge clamping Keil Klemmung
X	Back boring Rückwärts drehen

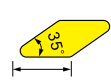

Cutting edge length Schneidkantenlänge							
insert shape	C	D	R	S	T	V	W
							
Diameter of incircle (mm)	Cutting edge length Schneidkantenlänge						
5.556	---	---	---	---	09	---	---
6.350	06	07	---	---	11	---	---
9.525	09	11	09	09	16	16	06
12.700	12	15	12	12	22	22	08
15.875	16	19	15	15	27	---	---
19.050	19	---	19	19	33	---	---
25.400	25	---	25	25	44	---	---

Turning · Drehen

Internal turning tools · Drehwerkzeuge zur Innenbearbeitung

CN** Toolholder · Halter

P-Clamping / P-Halter

PCLNR/L

Kr:95°





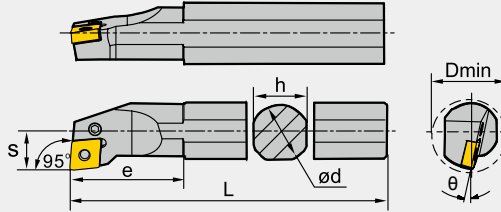











R type
Rechtsausführung



Type · Typ	Stock Lager		Dimension (mm) Abmessung							Screw Schraube	Wrench Schlüssel	Lever Kniehebel	Shim Unterlage	Shim pin Rohrstift
	R	L	Dmin	ød	h	L	s	θ	e					
S16M-PCLNR/L09	●	●	20	16	15	150	11	-12°	28	LEM5×9B	WH20L	L3C	—	—
S16R-PCLNR/L09	●	●	20	16	15	200	11	-12°	28					
S20Q-PCLNR/L09	●	●	25	20	18	180	13	-11°	31					
S20S-PCLNR/L09	●	●	25	20	18	250	13	-11°	31					
S25Q-PCLNR/L09	●	●	32	25	23	180	17	-10°	35					
S25T-PCLNR/L09	●	●	32	25	23	300	17	-10°	35	LEM6×13.4A	WH25L	L4A	—	—
S25Q-PCLNR/L12	●	●	32	25	23	180	17	-12°	40					
S25T-PCLNR/L12	●	●	32	25	23	300	17	-12°	40					
S32R-PCLNR/L12	●	●	44	32	30	200	22	-10°	50					
S32U-PCLNR/L12	●	●	44	32	30	350	22	-10°	50					
S40S-PCLNR/L12	●	●	54	40	37	250	27	-10°	55	LEM8×21	WH30L	L4	C12APB	SP4
S40V-PCLNR/L12	●	●	54	40	37	400	27	-10°	55					
S50S-PCLNR/L12	●	●	63	50	47	250	35	-10°	56					
S50W-PCLNR/L12	●	●	63	50	47	450	35	-10°	56					
S50S-PCLNR/L19	●	●	63	50	47	250	35	-10°	63					
S50W-PCLNR/L19	●	●	63	50	47	450	35	-10°	63	LEM10×27	WH40L	L6	C19AP	SP6
◆ A25R-PCLNR/L12	●	●	32	25	24	200	17	-12°	40					
◆ A32S-PCLNR/L12	●	●	44	32	31	250	22	-10°	50					

● ex stock · ab Lager ○ on demand · auf Anfrage ◆ Toolholder with holes for coolant · Klemhalter mit Kühlmittelbohrung

Applicable insert Wendeschneidplatten		Finishing Schlichten		Semi-Finishing Mittlere Bearbeitung		Roughing Schruppen		Cast iron machining Grauguss Bearbeitung				
Application Anwendung												
insert shape Schneidplattenform	DF		A46	PM		A47	DR Double -side		A49	Flat		A51
	WG Wiper inserts		A46	DM		A48	DR Single- side		A50			
	SF		A46	EM		A48	ER Double -side		A50			
	EF		A46	NM		A49	ER Single- side		A50			
	NF		A47									
Type · Typ	**PCLNR/L09	CN**0903**		CN**0903**						CN**0903**		
	PCLNR/L12	CN1204**		CN**1204**		CN**1204**		CN**1204**		CN**1204**		
	PCLNR/L19					CN1906**		CN**1906**		CN**1906**		

◆ Toolholder with holes for Coolant · Klemmhalter mit Kühlmittelbohrung

● ex stock · ab Lager ○ on demand · auf Anfrage

Turning · Drehen

Internal turning tools · Drehwerkzeuge zur Innenbearbeitung

CN** Toolholder · Halter

P-Clamping / P-Halter

PDSNR/L

Kr:62°30'

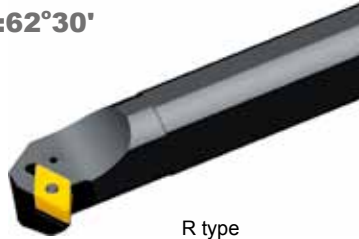

R type
Rechtsausführung

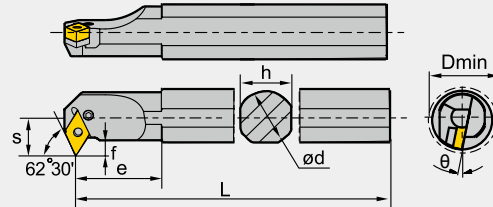

Type · Typ	Stock Lager		Dimension (mm) Abmessung								Screw Schraube	Wrench Schlüssel	Lever Kniehebel	Shim Unterlage	Shim pin Rohrstift
	R	L	Dmin	ød	h	L	S	θ	e	f					
S32R-PDSNR/L15	●	●	40	32	30	200	22	-11°	45	8.5	LEM8×21	WH30L	L4B	D15AP	SP4
S32U-PDSNR/L15	●	●	40	32	30	350	22	-11°	45	8.5					
S32R-PDSNR/L15-3	●	●	40	32	30	200	22	-11°	45	8.5	LEM8×21	WH30L	L4	D15AP	SP4
S32U-PDSNR/L15-3	●	●	40	32	30	350	22	-11°	45	8.5					
S40S-PDSNR/L15	●	●	50	40	37	250	27	-11°	43	9.4	LEM8×21	WH30L	L4B	D15AP	SP4
S40V-PDSNR/L15	●	●	50	40	37	400	27	-11°	43	9.4					
S40S-PDSNR/L15-3	●	●	50	40	37	250	27	-11°	43	9.4	LEM8×21	WH30L	L4	D15AP	SP4
S40V-PDSNR/L15-3	●	●	50	40	37	400	27	-11°	43	9.4					
◆ A32S-PDSNR/L15	●	●	40	32	31	250	22	-11°	45	8.5	LEM8×21	WH30L	L4B	D15AP	SP4
◆ A32S-PDSNR/L15-3	●	●	40	32	31	250	22	-11°	45	8.5	LEM8×21	WH30L	L4	D15AP	SP4

Applicable insert
Wendeschneidplatten

Application Anwendung	Finishing Schlichten	Semi-Finishing Mittlere Bearbeitung	Roughing Schruppen	Cast iron machining Grauguss Bearbeitung
insert shape Schneidplattenform	DF A53	PM A55	DR Double-side A56	Flat A58
	SF A53	DM A55	DR Single-side A58	
	EF A54	EM A56	ER Double-side A58	
	NF A54	NM A56	ER Single-side A58	
Type · Typ	**PDSNR/L-15-3	DN**1504**	DN**1504**	DN**1504**
	PDSNR/L-15	DN1506**	DN**1506**	DN**1506**

● ex stock · ab Lager ○ on demand · auf Anfrage ◆ Toolholder with holes for coolant · Klemhalter mit Kühlmittelbohrung

DN** Toolholder · Halter

P-Clamping / P-Halter





PDUNR/L

Kr:93°

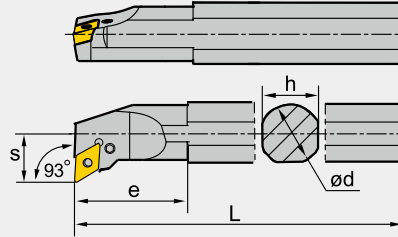

R type
Rechtausführung



Type · Typ	Stock Lager		Dimension (mm) Abmessung							Screw Schraube	Wrench Schlüssel	Lever Kniehebel	Shim Unterlage	Shim pin Rohrstift
	R	L	Dmin	ød	h	L	S	θ	e					
S20Q-PDUNR/L11	●	●	25	20	18	180	13	-16°	30	LEM5×12B	WH20L	L3D	—	—
S20S-PDUNR/L11	●	●	25	20	18	250	13	-16°	30					
S25Q-PDUNR/L11	●	●	32	25	23	180	17	-13°	35					
S25T-PDUNR/L11	●	●	32	25	23	300	17	-13°	35	LEM6×17	WH25L	L3	D11AP	SP3
S32R-PDUNR/L11	●	●	40	32	30	200	22	-16°	40					
S32U-PDUNR/L11	●	●	40	32	30	350	22	-16°	40					
S32R-PDUNR/L15	●	●	40	32	30	200	22	-16°	50	LEM8×21	WH30L	L4B	D15AP	SP4
S32U-PDUNR/L15	●	●	40	32	30	350	22	-16°	50					
S32R-PDUNR/L15-3	●	●	40	32	30	200	22	-16°	50					
S32U-PDUNR/L15-3	●	●	40	32	30	350	22	-16°	50	LEM8×21	WH30L	L4	D15AP	SP4
S40S-PDUNR/L15	●	●	50	40	37	250	27	-11°	50					
S40V-PDUNR/L15	●	●	50	40	37	400	27	-11°	50					
S40S-PDUNR/L15-3	●	●	50	40	37	250	27	-11°	50	LEM8×21	WH30L	L4B	D15AP	SP4
S40V-PDUNR/L15	●	●	50	40	37	400	27	-11°	50					
◆ A32S- PDUNR/L15	●	●	40	32	31	250	22	-16°	50					
◆ A32S- PDUNR/L15-3	●	●	40	32	31	250	22	-16°	50	LEM8×21	WH30L	L4	D15AP	SP4

◆ Toolholder with holes for Coolant · Klemmhalter mit Kühlmittelbohrung















● ex stock · ab Lager ○ on demand · auf Anfrage

Turning · Drehen

Internal turning tools · Drehwerkzeuge zur Innenbearbeitung

A

General Turning · Allgemeine Drehbearbeitung

Applicable insert Wendeschneidplatten		Finishing Schlichten		Semi-Finishing Mittlere Bearbeitung		Roughing Schruppen		Cast iron machining Grauguss Bearbeitung				
Application Anwendung												
insert shape Schneidplattenform	DF		A53	PM		A55	DR Double -side		A56	Flat		A58
	WG Wiper inserts		A53	DM		A55	DR Single- side		A58			
	SF		A53	EM		A56	ER Double -side		A58			
	EF		A54	NM		A56	ER Single- side		A58			
	NF		A54									
Type · Typ	**PDUNR/L11	DN**1104**		DN**1104**								
	PDUNR/L15-3	DN1504**		DN**1504**						DN**1504**		
	PDUNR/L15	DN1506**		DN**1506**		DN**1506**		DN**1506**		DN**1506**		

● ex stock · ab Lager ○ on demand · auf Anfrage ◆ Toolholder with holes for coolant · Klemmhalter mit Kühlmittelbohrung

SN** Toolholder · Halter

P-Clamping / P-Halter

PSKNR/L

Kr:75°

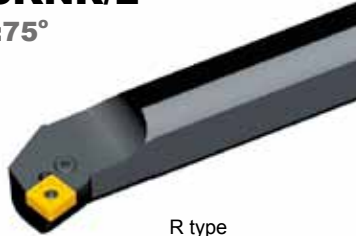

R type
Rechtsausführung

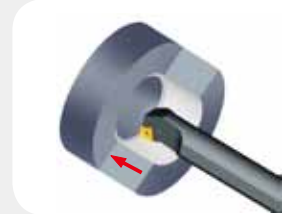
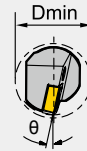
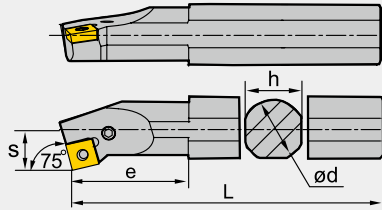

Type · Typ	Stock Lager		Dimension (mm) Abmessung							Screw Schraube	Wrench Schlüssel	Lever Kniehebel	Shim Unterlage	Shim pin Rohrstift
	R	L	Dmin	ød	h	L	S	θ	e					
S25Q-PSKNR/L12			32	25	23	180	17	-12°	42	LEM6×13.4A	WH25L	L4A	—	—
S25T-PSKNR/L12	●	●	32	25	23	300	17	-12°	42					
S32R-PSKNR/L12	●	●	44	32	30	200	22	-10°	45					
S32U-PSKNR/L12	●	●	44	32	30	350	22	-10°	45	LEM8×21	WH30L	L4	S12APB	SP4
S40S-PSKNR/L12	●	●	54	40	37	250	27	-10°	50					
S40V-PSKNR/L12	●	●	54	40	37	400	27	-10°	50					
◆ A25R-PSKNR/L12	●	●	32	25	24	200	17	-12°	42	LEM6×13.4A	WH25L	L4A	—	—
◆ A32S-PSKNR/L12	●	●	44	32	31	250	22	-12°	50	LEM8×21	WH30L	L4	S12APB	SP4

Applicable insert Wendeschneidplatten		Finishing Schichten		Semi-Finishing Mittlere Bearbeitung		Roughing Schruppen		Heavy Duty Schwerzerspannung		Cast iron machining Grauguss Bearbeit.		
Application Anwendung	insert shape Schneidplattenform	SF		DF		PM		DR		Flat		
			A60		A59		A60		A62		A65	
				EF		DM		DR				
					A59		A61		A62			
					EM		ER					
						A61		A63				
					NM		ER					
						A62		A63				
Type · Typ	**PSKNR/L12	SN**1204**		SN**1204**		SN**1204**		SN**1204**		SN**1204**		

◆ Toolholder with holes for Coolant · Klemmhalter mit Kühlmittelbohrung ● ex stock · ab Lager ○ on demand · auf Anfrage

Turning · Drehen

Internal turning tools · Drehwerkzeuge zur Innenbearbeitung

TN** Toolholder · Halter

P-Clamping / P-Halter

PTFNR/L

Kr:90°





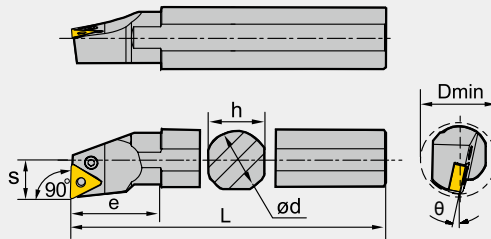







R type
Rechtsausführung



Type · Typ	Stock Lager		Dimension (mm) Abmessung							Screw Schraube	Wrench Schlüssel	Lever Kniehebel	Shim Unterlage	Shim pin Rohrstift
	R	L	Dmin	ød	h	L	S	θ	e					
S16M-PTFNR/L11	●	●	20	16	15	150	11	-14°	28	LEM5×9B	WH20L	L2	—	—
S16R-PTFNR/L11	●	●	20	16	15	200	11	-14°	28					
S20Q-PTFNR/L11			25	20	18	180	13	-12°	31					
S20S-PTFNR/L11	●	●	25	20	18	250	13	-12°	31					
S25Q-PTFNR/L11			32	25	23	180	17	-10°	35					
S25T-PTFNR/L11	●	●	32	25	23	300	17	-10°	35	LEM5×12B	WH20L	L3B	—	—
S25Q-PTFNR/L16			32	25	23	180	17	-12°	42					
S25T-PTFNR/L16	●	●	32	25	23	300	17	-12°	42					
S32R-PTFNR/L16			44	32	30	200	22	-10°	50	LEM6×17	WH25L	L3	T16APB	SP3
S32U-PTFNR/L16	●	●	44	32	30	350	22	-10°	50					
S40S-PTFNR/L16			54	40	37	250	27	-10°	55					
S40V-PTFNR/L16	●	●	54	40	37	400	27	-10°	55					
◆ A25R-PTFNR/L16			32	25	24	200	17	-12°	40					
◆ A32S-PTFNR/L16	●	●	44	32	31	250	22	-10°	50					

Applicable insert
Wendeschneidplatten

Application Anwendung	Finishing Schlichten	Semi-Finishing Mittlere Bearbeitung	Roughing Schruppen	Cast iron machining Grauguss Bearbeitung
insert shape Schneidplattenform	DF  A68	PM  A69	DR Double-side  A70	Flat  A73
	WG Wiper inserts  A68	DM  A69	DR Single-side  A71	
	SF  A68	EM  A70	ER Double-side  A71	
	EF  A68			
Type · Typ	**PTFNR/L11	TN**1103**	TN**1103**	TN**1103**
	PTFNR/L16	TN1604**	TN**1604**	TN**1604**

● ex stock · ab Lager ○ on demand · auf Anfrage ◆ Toolholder with holes for coolant · Klemhalter mit Kühlmittelbohrung

WN** Toolholder · Halter

P-Clamping / P-Halter

PWLNR/L

Kr:95°





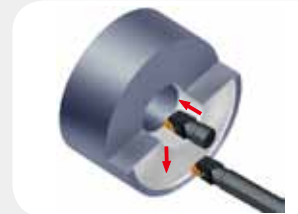
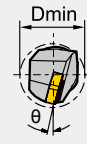
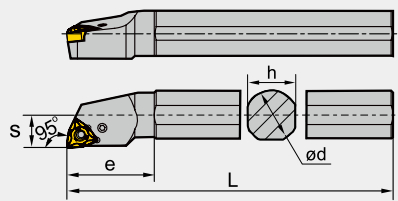







R type
Rechtsausführung



Type · Typ	Stock Lager		Dimension (mm) Abmessung							Screw Schraube	Wrench Schlüssel	Lever Kniehebel	Shim Unterlage	Shim pin Rohrstift
	R	L	Dmin	ød	h	L	S	θ	e					
S16M-PWLNR/L06	●	●	20	16	15	150	11	-13°	25	LEM5X12B	WH20L	L3B	—	—
S16R-PWLNR/L06			20	16	15	200	11	-13°	25					
S20Q-PWLNR/L06	●	●	25	20	18	180	13	-13°	35					
S20S-PWLNR/L06			25	20	18	250	13	-13°	35					
S25Q-PWLNR/L06	●	●	32	25	23	180	17	-13°	35					
S25T-PWLNR/L06			32	25	23	300	17	-13°	35					
S20Q-PWLNR/L08	●	●	25	20	18	180	13	-13°	32	LEM6X13.4A	WH25L	L4A	—	—
S20S-PWLNR/L08			25	20	18	250	13	-13°	32					
S25Q-PWLNR/L08		●	32	25	23	180	17	-13°	45					
S25T-PWLNR/L08			32	25	23	300	17	-13°	45					
S32R-PWLNR/L08	●	●	40	32	30	200	22	-15°	50	LEM8X21	WH30L	L4	W08AP	SP4
S32U-PWLNR/L08	●	●	40	32	30	350	22	-15°	50					
◆ A25T-PWLNR/L08			32	25	23	300	17	-13°	45	LEM6X13.4A	WH25L	L4A	—	—
◆ A32R-PWLNR/L08			40	32	30	200	22	-15°	50	LEM8X21	WH30L	L4	W08AP	SP4

Applicable insert
Wendeschneidplatten

Application Anwendung	Finishing Schichten	Semi-Finishing Mittlere Bearbeitung	Roughing Schruppen	Cast iron machining Grauguss Bearbeitung
insert shape Schneidplattenform	DF  A76	PM  A78	DR  A79 Double side	Flat  A79
	WG  A76 Wiper inserts	DM  A78		
	SF  A77	EM  A78		
	EF  A77	NM  A79		
	NF  A77			

Type · Typ	** -PWLNR/L06	** -PWLNR/L08
	WN**0604**	WN**0804**
	WN**0604**	WN**0804**
	WN**0604**	WN**0804**
	WN**0604**	WN**0804**

◆ Toolholder with holes for Coolant · Klemmhalter mit Kühlmittelbohrung ● ex stock · ab Lager ○ on demand · auf Anfrage

Turning · Drehen

Internal turning tools · Drehwerkzeuge zur Innenbearbeitung

CC** Toolholder · Halter

S-Clamping / S-Halter

SCLCR/L

Kr:95°





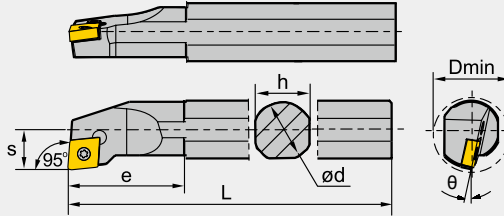





R type
Rechtsausführung



Type · Typ	Stock Lager		Dimension (mm) Abmessung							Screw Schraube	Wrench Schlüssel	Shim Unterlage	Shim Screw, Unterlage Schraube
	R	L	Dmin	ød	h	L	S	θ	e				
S08K-SCLCR/L06	●	●	10	8	7	125	5	-15°	14				
S10M-SCLCR/L06	●	●	12	10	9	150	6	-13°	14	I60M2.5×5.5	WT07IP	—	—
S12M-SCLCR/L06	●	●	16	12	11	150	9	-10°	25				
S12M-SCLCR/L09	●	●	16	12	11	150	9	-10°	25				
S16M-SCLCR/L09	●	●	20	16	15	150	11	-12°	32.5				
S16R-SCLCR/L09	●	●	20	16	15	200	11	-12°	32.5	I60M3.5×8	WT15IP	—	—
S20Q-SCLCR/L09	●	●	25	20	18	180	13	-8°	38				
S20S-SCLCR/L09	●	●	25	20	18	250	13	-8°	38				
S25Q-SCLCR/L09	●	●	32	25	23	180	17	-6°	45				
S25T-SCLCR/L09	●	●	32	25	23	300	17	-6°	45	I60M3.5×10	WT15IP	—	—
S25Q-SCLCR/L12	●	●	32	25	23	180	17	-6°	45	I60M4×11X	WT15IP	—	—
S25T-SCLCR/L12	●	●	32	25	23	300	17	-6°	45	I60M4×11X	WT15IP	—	—
S32R-SCLCR/L12	●	●	40	32	30	200	22	-10°	50				
S32U-SCLCR/L12	●	●	40	32	30	350	22	-10°	50	I60M4×11X	WH40L WT15IP	C12BS	SM6×10XA
S40S-SCLCR/L12	●	●	50	40	37	250	27	-8°	60				
S40V-SCLCR/L12	●	●	50	40	37	400	27	-8°	60				
♦ A08F-SCLCR/L06	●	●	10	8	7.5	80	5	-15°	14				
♦ A10H-SCLCR/L06	●	●	12	10	9.5	100	6	-13°	14	I60M2.5×5.5	WT07IP	—	—
♦ A12K-SCLCR/L06	●	●	16	12	11.5	125	9	-10°	25				
♦ A12K-SCLCR/L09	●	●	16	12	11.5	125	9	-10°	25				
♦ A16M-SCLCR/L09	●	●	20	16	15.5	150	11	-12°	32.5	I60M3.5×8	WT15IP	—	—
♦ A20Q-SCLCR/L09	●	●	25	20	19	180	13	-8°	38				
♦ A25R-SCLCR/L09	●	●	32	25	24	200	17	-6°	45	I60M3.5×10			
♦ A25R-SCLCR/L12	●	●	32	25	24	200	17	-6°	45				
♦ A32S-SCLCR/L12	●	●	40	32	31	250	22	-10°	50	I60M4×11X	WT15IP WH40L, WT15IP	C12BS	SM6×10XA
AH08K-SCLCR/L06	○	○	10	8	7	125	5	13	20				
AH10K-SCLCR/L06	○	○	12	10	9	125	6	12	20	I60M2.5×5.5	WT07IP	—	—
AH12M-SCLCR/L06	○	○	14	12	11	150	7	12	20				
AH16Q-SCLCR/L09	○	○	18	16	14	180	11	8	27	I60M3.5×8	WT15IP	—	—
AH20R-SCLCR/L09	○	○	23	20	18	200	13	7	27				
AH25R-SCLCR/L12	○	○	28	25	23	200	15.5	7	40	I60M4×11X		C12BS	SM6×10XA

● ex stock · ab Lager ○ on demand · auf Anfrage ♦ Toolholder with holes for coolant · Klemmhalter mit Kühlmittelbohrung

Applicable insert Wendeschneidplatten		Extra Finishing Feinbearbeitung	Finishing Schlichten	Semi-finishing Mittlere Bearbeit.	Roughing Schruppen	Al machining Alu Bearbeitung	Cast iron machining Grauguss Bearbeit.					
Application Anwendung	SF	 A84	HF	 A84	HM	 A85	HR	 A86	LH	 A86	Flat	 A86
	insert shape Schneidplattenform		EF	 A85	EM	 A85						
Type · Typ	**SCLCR/L06	CC**0602**	CC**0602**	CC**0602**	CC**0602**	CCG0602**	CC**0602**					
	SCLCR/L09	CC09T3**	CC**09T3**	CC**09T3**	CC**09T3**	CCG09T3**	CC**09T3**					
	SCLCR/L12	CC1204**	CC**1204**	CC**1204**	CC**1204**	CCG1204**	CC**1204**					

◆ Toolholder with holes for Coolant · Klemmhalter mit Kühlmittelbohrung

● ex stock · ab Lager ○ on demand · auf Anfrage

Turning · Drehen

Internal turning tools · Drehwerkzeuge zur Innenbearbeitung

DC** Toolholder · Halter

S-Clamping / S-Halter

SDQCR/L

Kr:107°30'





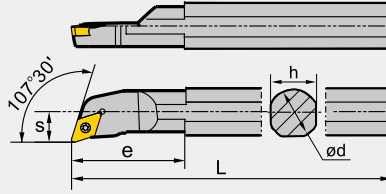





R type
Rechtsausführung



Type · Typ	Stock Lager		Dimension (mm) Abmessung							Screw Schraube	Wrench Schlüssel		
	R	L	Dmin	ød	h	L	S	θ	e				
S10M-SDQCR/L07	●	●	13	10	9	150	7	-8°	20	I60M2.5×5.5	WT07IP		
S12M-SDQCR/L07	●	●	16	12	11	150	9	-8°	22				
S16M-SDQCR/L07	●	●	20	16	15	150	11	-6°	27	I60M2.5×6.5	WT07IP		
S16R-SDQCR/L07	●	●	20	16	15	200	11	-6°	27				
S20Q-SDQCR/L11	●	●	25	20	18	180	13	-6°	32	I60M3.5×8	WT15IP		
S20S-SDQCR/L11	●	●	25	20	18	250	13	-6°	32				
S25Q-SDQCR/L11	●	●	32	25	23	180	17	-6°	32	I60M3.5×10	WT15IP		
S25T-SDQCR/L11	●	●	32	25	23	300	17	-6°	32				
♦ A10H-SDQCR/L07	●	●	13	10	9.5	100	7	-8°	20	I60M2.5×5.5	WT07IP		
♦ A12K-SDQCR/L07	●	●	16	12	11.5	125	9	-8°	22				
♦ A16M-SDQCR/L11	●	●	20	16	15.5	150	11	-6°	27	I60M3.5×8	WT15IP		
♦ A20Q-SDQCR/L11	●	●	25	20	19	180	13	-6°	32				
♦ A25R-SDQCR/L11	●	●	32	25	24	200	17	-6°	32	I60M3.5×10	WT15IP		
AH10K-SDQCR/L07	○	○	13	10	9	125	8	10	20	I60M2.5×6.5	WT07IP		
AH12M-SDQCR/L07	○	○	16	12	11	150	9.5	8	20				
AH16Q-SDQCR/L07	○	○	20	16	14	180	12	6	30	I60M3.5×8	WT15IP		
AH20R-SDQCR/L11	○	○	25	20	18	200	14.5	6	40				
AH25R-SDQCR/L11	○	○	32	25	23	200	17	6	40				

Applicable insert
Wendeschneidplatten

Application Anwendung	Extra Finishing Feinbearbeitung	Finishing Schlichten	Semi-finishing Mittlere Bearbeit.	Roughing Schruppen	Al machining Alu Bearbeitung	Cast iron machining Grauguss Bearbeit.
insert shape Schneidplattenform	SF  A88	HF  A88	HM  A89	HR  A90	LH  A90	Flat  A90
		EF  A89	EM  A89			
Type · Typ	**SDQCR/L07	DC**0702**	DC**0702**	DC**0702**	DCGX0702**	DC**0702**
	SDQCR/L11	DC11T3**	DC**11T3**	DC**11T3**	DCGX11T3**	DC**11T3**

● ex stock · ab Lager ○ on demand · auf Anfrage ♦ Toolholder with holes for coolant · Klemhalter mit Kühlmittelbohrung

DC** Toolholder · Halter

S-Clamping / S-Halter

SDUCR/L

Kr:93°





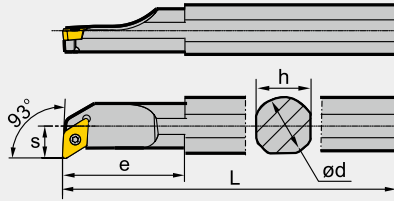





R type
Rechtsausführung



Type · Typ	Stock Lager		Dimension (mm) Abmessung							Screw Schraube	Wrench Schlüssel		
	R	L	Dmin	ød	h	L	S	θ	e				
S10M-SDUCR/L07	●	●	13	10	9	150	7	-8°	0	I60M2.5×5.5	WT07IP		
S12M-SDUCR/L07	●	●	16	12	11	150	9	-8°	22				
S16M-SDUCR/L07	●	●	20	16	15	150	11	-6°	27	I60M2.5×6.5	WT07IP		
S16R-SDUCR/L07	●	●	20	16	15	200	11	-6°	27				
S20Q-SDUCR/L11	●	●	25	20	18	180	13	-6°	40	I60M3.5×8	WT15IP		
S20S-SDUCR/L11	●	●	25	20	18	250	13	-6°	40				
S25Q-SDUCR/L11	●	●	32	25	23	180	17	-6°	46	I60M3.5×10	WT15IP		
S25T-SDUCR/L11	●	●	32	25	23	300	17	-6°	46				
♦ A10H-SDUCR/L07	●	●	13	10	9.5	100	7	-8°	0	I60M2.5×5.5	WT07IP		
♦ A12K-SDUCR/L07	●	●	16	12	11.5	125	9	-8°	22				
♦ A16M-SDUCR/L07	●	●	20	16	15.5	150	11	-6°	27	I60M2.5×6.5	WT07IP		
♦ A20Q-SDUCR/L11	●	●	25	20	19	180	13	-6°	40				
♦ A25R-SDUCR/L11	●	●	32	25	24	200	17	-6°	46	I60M3.5×10	WT15IP		
AH10K-SDUCR/L07	○	○	14	10	9	125	8.3	-8	20	I60M2.5×6.5	WT07IP		
AH12M-SDUCR/L07	○	○	16	12	11	150	9.3	-8	25				
AH16Q-SDUCR/L07	○	○	20	16	14	180	11.3	-6	25	I60M3.5×8	WT15IP		
AH20R-SDUCR/L11	○	○	26	20	18	200	16.1	-6	30				
AH25R-SDUCR/L11	○	○	32	25	23	200	18.6	5	40				

Applicable insert
Wendeschneidplatten

Application Anwendung	Extra Finishing Feinbearbeitung	Finishing Schlichten	Semi-finishing Mittlere Bearbeit.	Roughing Schruppen	Al machining Alu Bearbeitung	Cast iron machining Grauguss Bearbeit.
insert shape Schneidplattenform	SF  A88	HF  A88	HM  A89	HR  A90	LH  A90	Flat  A90
		EF  A89	EM  A89			
Type · Typ	**SDUCR/L07	DC**0702**	DC**0702**	DC**0702**	DCGX0702**	DC**0702**
	SDUCR/L11	DC11T3**	DC**11T3**	DC**11T3**	DCGX11T3**	DC**11T3**

♦ Toolholder with holes for Coolant · Klemmhalter mit Kühlmittelbohrung

● ex stock · ab Lager ○ on demand · auf Anfrage

Turning · Drehen

Internal turning tools · Drehwerkzeuge zur Innenbearbeitung

DC** Toolholder · Halter

S-Clamping / S-Halter

SDZCR/L

Kr:85°





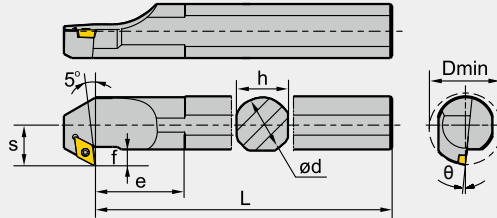





R type
Rechtsausführung



Type · Typ	Stock Lager		Dimension (mm) Abmessung								Screw Schraube	Wrench Schlüssel	Shim Unterlage	Shim/ Screw Schraube Unterlage
	R	L	Dmin	ød	h	L	S	θ	e	f				
S25Q-SDZCR/L11	●	●	32	25	23	180	17	-6°	30	6.9	I60M3.5×10	WT15IP		
S25T-SDZCR/L11	●	●	32	25	23	300	17	-6°	30	6.9				
S32R-SDZCR/L11	●	●	40	32	30	200	22	-6°	.39	8.4	I60M3.5×12	WT15IP WH35L	D11BS	SM5×8.65XA
S32U-SDZCR/L11	●	●	40	32	30	350	22	-6°	.39	8.4				
S40S-SDZCR/L11	●	●	50	40	37	250	27	-4°	47	9.4				
S40V-SDZCR/L11	●	●	50	40	37	400	27	-4°	47	9.4				
◆ A25R-SDZCR/L11	●	●	32	25	24	200	17	-6°	30	4.5	I60M3.5×10	WT15IP		
◆ A32S-SDZCR/L11	●	●	40	32	31	250	22	-6°	39	6.0	I60M3.5×12	WT15IP WH35L	D11BS	SM5×8.65XA

Applicable insert
Wendeschneidplatten

Application Anwendung	Extra Finishing Feinbearbeitung	Finishing Schichten	Semi-finishing Mittlere Bearbeit.	Roughing Schruppen	Al machining Alu Bearbeitung	Cast iron machining Grauguss Bearbeit.	
insert shape Schneidplattenform	SF  A88	HF  A88	HM  A89	HR  A90	LH  A90	 A90	
		EF  A89	EM  A89				
Type · Typ	**SDZCR/L11	DC**11T3**	DC**11T3**	DC**11T3**	DC**11T3**	DCG11T3**	DC**11T3**

● ex stock · ab Lager ○ on demand · auf Anfrage ◆ Toolholder with holes for coolant · Klemmhalter mit Kühlmittelbohrung

SC** Toolholder · Halter

S-Clamping / S-Halter

SSKCR/L

Kr:75°





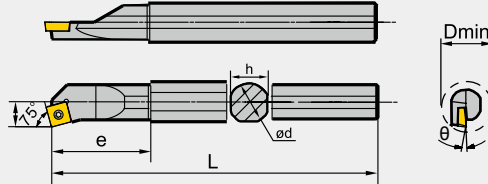



R type
Rechtausführung



Type · Typ	Stock Lager		Dimension (mm) Abmessung							Screw Schraube	Wrench Schlüssel	Shim Unterlage	Shim/ Screw Schraube Unterlage
	R	L	Dmin	ød	h	L	S	θ	e				
S12M-SSKCR/L09	●	●	16	12	11	150	9	-10	26	I60M3.5×8	WT15IP		
S16M-SSKCR/L09	●	●	20	16	15	150	11	-11	32.5				
S16R-SSKCR/L09	●	●	20	16	15	200	11	-11	32.5				
S20Q-SSKCR/L09	●	●	25	20	18	180	13	-6	34.5				
S20S-SSKCR/L09	●	●	25	20	18	250	13	-6	34.5				
S25Q-SSKCR/L12	●	●	32	25	23	180	17	-8	36.3	I60M4×11X	WT15IP	S12BS	SM6×10XA
S25T-SSKCR/L12	●	●	32	25	23	300	17	-8	36.3				
S32R-SSKCR/L12	●	●	40	32	30	200	22	-10	43.5				
S32U-SSKCR/L12	●	●	40	32	30	350	22	-10	43.5	I60M3.5×8	WT15IP		
♦ A12K-SSKCR/L09	●	●	16	12	11	125	9	-10	26				
♦ A16M-SSKCR/L09	●	●	20	16	15	150	11	-11	32.5				
♦ A20Q-SSKCR/L09	●	●	25	20	19	180	13	-6	34.5				
♦ A25R-SSKCR/L12	●	●	32	25	24	200	17	-8	41.3				
♦ A32S-SSKCR/L12	●	●	40	32	31	250	22	-10	42.8	I60M4×11X	WT15IP WH40L	S12BS	SM6×10XA

Applicable insert
Wendeschneidplatten

Application Anwendung	Finishing Schlichten	Semi-finishing Mittlere Bearbeit.	Roughing Schruppen	Al machining Alu Bearbeitung	Cast iron machining Grauguss Bearbeit.
insert shape Schneidplattenform	HF  A94	HM  A94	HR  A95	LH  A95	Flat  A95
	EF  A94	EM  A94			
Type · Typ	**SSKCR/L09	SC**09T3**	SC**09T3**	SC**09T3**	SCGX09T3**
	SSKCR/L12		SC1204**	SC**1204**	SCGX1204**

♦ Toolholder with holes for Coolant · Klemmhalter mit Kühlmittelbohrung

● ex stock · ab Lager ○ on demand · auf Anfrage

Turning · Drehen

Internal turning tools · Drehwerkzeuge zur Innenbearbeitung

TC** Toolholder · Halter

S-Clamping / S-Halter

STFCR/L

Kr:91°/*Kr:90°





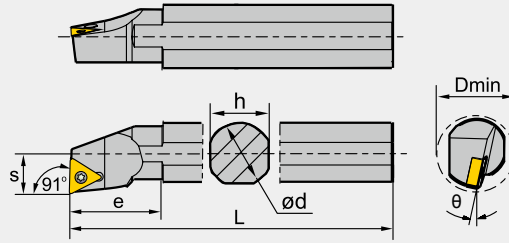





R type
Rechtsausführung



Type · Typ	Stock Lager		Dimension (mm) Abmessung							Screw Schraube	Wrench Schlüssel	Shim Unterlage	Shim/ Screw Schraube Unterlage
	R	L	Dmin	ød	h	L	S	θ	e				
S12M-STFCR/L11	●	●	16	12	11	150	9	-10°	30	I60M2.5×6.5	WT07IP		
S16M-STFCR/L11	●	●	20	16	15	150	11	-6°	35				
S16R-STFCR/L11	●	●	20	16	15	200	11	-6°	35				
S20Q-STFCR/L11	●	●	25	20	18	180	13	-3°	36	I60M3.5×10	WT15IP		
S20S-STFCR/L11	●	●	25	20	18	250	13	-3°	36				
S25Q-STFCR/L16	●	●	32	25	23	180	17	-6°	49				
S25T-STFCR/L16	●	●	32	25	23	300	17	-6°	49	I60M3.5×12	WT15IP WH35L	T16BS	SM5×8.65XA
S32R-STFCR/L16	●	●	40	32	30	200	22	-10°	50				
S32U-STFCR/L16	●	●	40	32	30	350	22	-10°	50				
S40S-STFCR/L16	●	●	50	40	37	250	27	-8°	60	I60M2.5×6.5	WT07IP		
S40V-STFCR/L16	●	●	50	40	37	400	27	-8°	60				
♦ A12K-STFCR/L11	●	●	16	12	11.5	125	9	-10°	26				
♦ A16M-STFCR/L11	●	●	20	16	15.5	150	11	-6°	30	I60M3.5×10	WT15IP		
♦ A20Q-STFCR/L11	●	●	25	20	19	180	13	-3°	36				
♦ A25R-STFCR/L16	●	●	32	25	24	200	17	-6°	45				
♦ A32S-STFCR/L16	●	●	40	32	31	250	22	-10°	49	I60M3.5×12	WT15IP	T16BS	SM5×8.65XA
*AH10K-STFCR/L11	○	○	12	10	9	125	7	12	16				
*AH12M-STFCR/L11	○	○	14	12	11	150	9	10	20				
*AH16Q-STFCR/L11	○	○	18	16	14	180	11	8	25	I60M2.5×6.5	WT07IP		
*AH20R-STFCR/L11	○	○	23	20	18	200	13	7	32				
*AH25R-STFCR/L16	○	○	28	25	23	200	17	5	40				

Applicable insert Wendschneidplatten

Application Anwendung	Extra Finishing Feinbearbeitung	Finishing Schlichten	Semi-finishing Mittlere Bearbeit.	Roughing Schruppen	Al machining Alu Bearbeitung	Cast iron machining Grauguss Bearbeit.	
insert shape Schneidplattenform	SF  A98	HF  A99	HM  A101	HR  A101	LH  A101	 A102	
		EF  A100	EM  A100				
Type · Typ	**STFCR/L11	TC**1102**	TC**1102**	TC**1102**	TC**1102**	TCGX1102**	TC**1102**
	STFCR/L16	TC16T3**	TC**16T3**	TC**16T3**	TC**16T3**	TCGX16T3**	TC**16T3**

● ex stock · ab Lager ○ on demand · auf Anfrage ♦ Toolholder with holes for coolant · Klemhalter mit Kühlmittelbohrung

VC** Toolholder · Halter

S-Clamping / S-Halter



SVQCR/L

Kr:107°30'



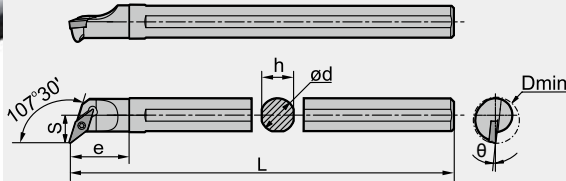

R type
Rechtausführung



Type · Typ	Stock Lager		Dimension (mm) Abmessung							Screw Schraube	Wrench Schlüssel		
	R	L	Dmin	ød	h	L	S	θ	e				
S16Q-SVQCR/L11	●	●	22	16	15	180	13	-6°	28	I60M2.5×6.5	WT07IP		
S20R-SVQCR/L11	●	●	26	20	18	200	15	-4°	32				

Applicable insert
Wendeschneidplatten

Application Anwendung	Extra Finishing Feinbearbeitung	Finishing Schlichten	Al machining Alu Bearbeitung
insert shape Schneidplattenform	SF  A106	HF  A106	LH  A107
Type · Typ	**SVQCR/L11	VC**1103**	VC**1103**
		VCGX1103**	

◆ Toolholder with holes for Coolant · Klemmhalter mit Kühlmittelbohrung

● ex stock · ab Lager ○ on demand · auf Anfrage

Turning · Drehen

Internal turning tools · Drehwerkzeuge zur Innenbearbeitung

VC** Toolholder · Halter

S-Clamping / S-Halter



SVUCR/L

Kr:93°



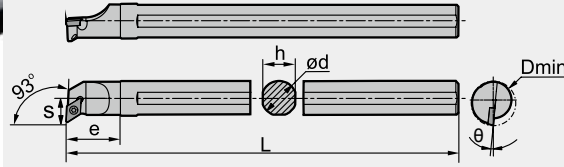

R type
Rechtsausführung



Type · Typ	Stock Lager		Dimension (mm) Abmessung							Screw Schraube	Wrench Schlüssel		
	R	L	Dmin	ød	h	L	S	θ	e				
S16Q-SVUCR/L11	●	●	24	16	15	180	15	-6°	25	I60M2.5×6.5			
S20R-SVUCR/L11	●	●	28	20	18	200	17	-4°	30				

Applicable insert
Wendeschneidplatten

Application Anwendung	Extra Finishing Feinbearbeitung	Finishing Schlichten	Al machining Alu Bearbeitung
insert shape Schneidplattenform	SF 	HF 	LH 
	A106	A106	A107
Type · Typ	**SVUCR/L11	VC**1103**	VC**1103**
			VCGX1103**

● ex stock · ab Lager ○ on demand · auf Anfrage ◆ Toolholder with holes for coolant · Klemmhalter mit Kühlmittelbohrung

VB** Toolholder · Halter

S-Clamping / S-Halter

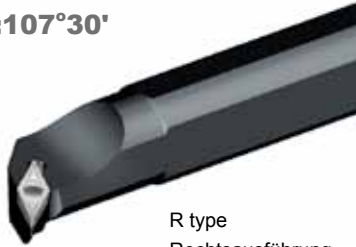

SVQBR/L

Kr:107°30'



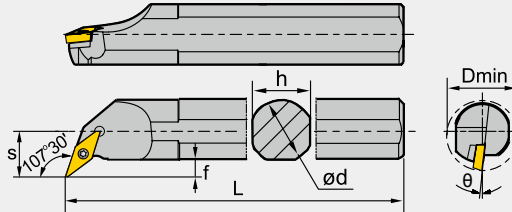

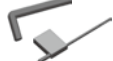

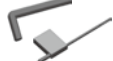
R type
Rechtsausführung



Type · Typ	Stock Lager		Dimension (mm) Abmessung								Screw Schraube	Wrench Schlüssel	Shim Unterlage	Shim/ Screw Schraube Unterlage
	R	L	Dmin	ød	h	L	S	θ	e	f				
S32R-SVQBR/L16			40	32	30	200	22	-8°	56	8.4	I60M3.5×12		V16BS	SM5×8.65XA
S32U-SVQBR/L16	●	●	40	32	30	350	22	-8°	56	8.4				
S40S-SVQBR/L16			50	40	37	250	27	-8°	64	9.4				
S40V-SVQBR/L16	●	●	50	40	37	400	27	-8°	64	9.4				
♦ A32S-SVQBR/L16	●	●	40	32	31	250	22	-8°	56	8.4				

Applicable insert
Wendeschneidplatten

Application Anwendung	Finishing Schlichten	Semi-Finishing Mittlere Bearbeitung	Roughing Schruppen	Cast iron machining Grauguss Bearbeitung
insert shape Schneidplattenform	EF  A108	HM  A109	HR  A109	Flat  A109
	NF  A108			
Type · Typ	**SVQBR/L16	VB**1604**	VB**1604**	VB**1604**

♦ Toolholder with holes for Coolant · Klemhalter mit Kühlmittelbohrung

● ex stock · ab Lager ○ on demand · auf Anfrage

Turning · Drehen

Internal turning tools · Drehwerkzeuge zur Innenbearbeitung

VB** Toolholder · Halter

S-Clamping / S-Halter

SVUBR/L

Kr:93°





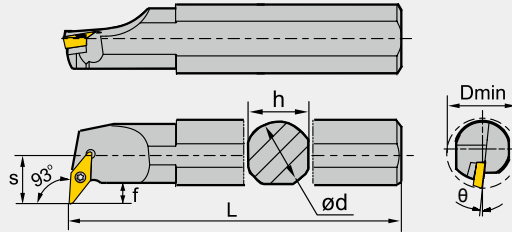



R type
Rechtsausführung



Type · Typ	Stock Lager		Dimension (mm) Abmessung								Screw Schraube	Wrench Schlüssel	Shim Unterlage	Shim/ Screw Schraube Unterlage
	R	L	Dmin	ød	h	L	S	θ	e	f				
S32R-SVUBR/L16	●	●	40	32	30	200	22	-8°	49	8.4	160M3.5×12	WT15IP WH35L	V16BS	SM5×8.65XA
S32U-SVUBR/L16	●	●	40	32	30	350	22	-8°	49	8.4				
S40S-SVUBR/L16	●	●	50	40	37	250	27	-8°	56.5	9.4				
S40V-SVUBR/L16	●	●	50	40	37	400	27	-8°	56.5	9.4				
◆ A32S-SVUBR/L16	●	●	40	32	31	250	22	-8°	49	8.4				

Applicable insert
Wendeschneidplatten

Application Anwendung	Finishing Schlichten	Semi-Finishing Mittlere Bearbeitung	Roughing Schruppen	Cast iron machining Grauguss Bearbeitung	
insert shape Schneidplattenform	HF  A108	HM  A109	HR  A109	Flat  A109	
	EF  A108	EM  A109			
	NF  A108				
Type · Typ	**SVUBR/L16	VB**1604**	VB**1604**	VB**1604**	VB**1604**

● ex stock · ab Lager ○ on demand · auf Anfrage ◆ Toolholder with holes for coolant · Klemhalter mit Kühlmittelbohrung

CP** Toolholder · Halter



S-Clamping / S-Halter

SCLPR/L Kr:95°

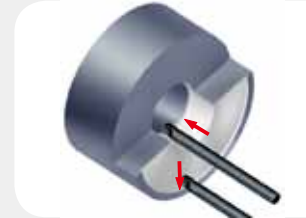
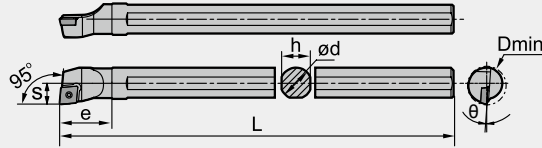

R type
Rechtausführung



Type · Typ	Stock Lager		Dimension (mm) Abmessung							Screw Schraube	Wrench Schlüssel		
	R	L	Dmin	ød	h	L	S	θ	e				
S10K-SCLPR/L06	●	●	12	10	9	125	6	-7°	17	I60M2.5×5.5	WT071P		
S12M-SCLPR/L06	●	●	16	12	11	150	8	-4°	20				
S16Q-SCLPR/L09	●	●	20	16	15	180	10	-4°	29	I60M3.5×8	WT151P		
S20R-SCLPR/L09	●	●	25	20	18	200	13	-4°	35				

Applicable insert
Wendeschneidplatten

Application
Anwendung

Extra Finishing
Feinbearbeitung

insert shape
Schneidplattenform

SF



A87

Type · Typ		
SCLPR/L06		CP0602**
SCLPR/L09		CP09T3**

◆ Toolholder with holes for Coolant · Klemmhalter mit Kühlmittelbohrung

● ex stock · ab Lager ○ on demand · auf Anfrage

Turning · Drehen

Internal turning tools · Drehwerkzeuge zur Innenbearbeitung

DP** Toolholder · Halter

S-Clamping / S-Halter



SDQPR/L

Kr:107°30'

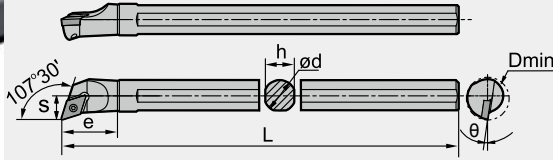

R type
Rechtsausführung



Type · Typ	Stock Lager		Dimension (mm) Abmessung							Screw Schraube	Wrench Schlüssel		
	R	L	Dmin	ød	h	L	S	θ	e				
S10K-SDQPR/L07	●	●	13	10	9	125	7	-8°	20	I60M2.5×5.5			
S12M-SDQPR/L07	●	●	16	12	11	150	9	-8°	22		WT07IP		
S16Q-SDQPR/L07	●	●	20	16	15	180	11	-6°	27	I60M2.5×6.5			
S16Q-SDQPR/L11	●	●	20	16	15	180	11	-6°	32				
S20R-SDQPR/L11	●	●	25	20	18	200	13	-6°	33	I60M3.5×8	WT15IP		

Applicable insert
Wendeschneidplatten

Application
Anwendung

Extra Finishing
Feinbearbeitung

insert shape
Schneidplattenform

SF



A91

Type · Typ	**SDQPR/L07	DP**0702**
	SDQPR/L11	DP11T3**

● ex stock · ab Lager ○ on demand · auf Anfrage ◆ Toolholder with holes for coolant · Klemhalter mit Kühlmittelbohrung

DP** Toolholder · Halter

S-Clamping / S-Halter



SDUPR/L

Kr:93°

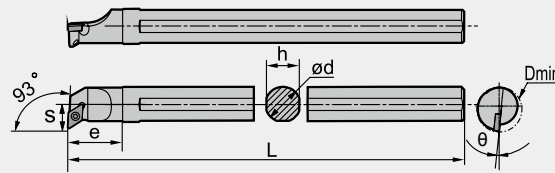

R type
Rechtausführung



Type · Typ	Stock Lager		Dimension (mm) Abmessung							Screw Schraube	Wrench Schlüssel				
	R	L	Dmin	ød	h	L	S	θ	e						
S10K-SDUPR/L07	●	●	15	10	9	125	9	-8°	18	I60M2.5×5.5					
S12M-SDUPR/L07	●	●	16	12	11	150	9	-8°	19				WT071P		
S16Q-SDUPR/L07	●	●	20	16	15	180	11	-6°	25			I60M2.5×6.5			

Applicable insert
Wendeschneidplatten

Application
Anwendung

Extra Finishing
Feinbearbeitung

insert shape
Schneidplattenform

SF



A91

Type · Typ	**SDUPR/L07	DP**0702**

◆ Toolholder with holes for Coolant · Klemmhalter mit Kühlmittelbohrung

● ex stock · ab Lager ○ on demand · auf Anfrage

Turning · Drehen

Internal turning tools · Drehwerkzeuge zur Innenbearbeitung

TP** Toolholder · Halter

S-Clamping / S-Halter



STUPR/L

Kr:93°

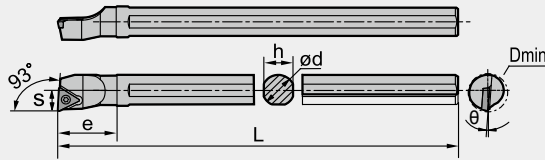

R type
Rechtsausführung



Type · Typ	Stock Lager		Dimension (mm) Abmessung							Screw Schraube	Wrench Schlüssel		
	R	L	Dmin	ød	h	L	S	θ	e				
S10K-STUPR/L09	●	●	12	10	9	125	6	-6°	20	I60M2.5×5.5	WT071P		
S12M-STUPR/L09	●	●	16	12	11	150	8	-4°	22				
S12M-STUPR/L11	●	●	16	12	11	150	8	-4°	25	I60M2.5×6.5	WT071P		
S16Q-STUPR/L11	●	●	20	16	15	180	10	-3°	27				

Applicable insert
Wendeschneidplatten

Application
Anwendung

Extra Finishing
Feinbearbeitung

insert shape
Schneidplattenform

SF



A103

Type · Typ	**STUPR/L09	TP**0902**
	STUPR/L11	TP1103**

● ex stock · ab Lager ○ on demand · auf Anfrage ◆ Toolholder with holes for coolant · Klemhalter mit Kühlmittelbohrung



CC** Toolholder · Halter

S-Clamping / S-Halter



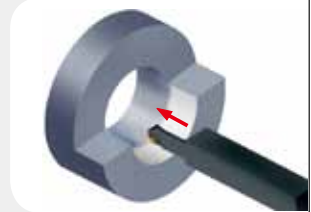
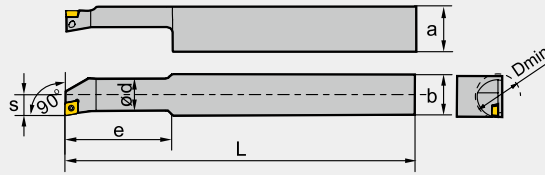





SCFCR

Kr:90°



Type · Typ	Stock Lager		Dimension (mm) Abmessung							Screw Schraube	Wrench Schlüssel		
	R	L	Dmin	ød	L	s	a	b	e				
S10M-SCFCR/L06S25	●	●	13	10	150	7	27	25	30	I60M2.5×5.5	WT07IP		
S12P-SCFCR/L06S25	●		16	12	170	9	27	25	35	I60M2.5×6.5			
S16Q-SCFCR/L09S25	●	●	20	16	180	11	27	25	40	I60M3.5×8	WT15IP		
S20R-SCFCR/L09S25	●		25	20	200	13	27	25	45				
S25R-SCFCR/L12S25	●		32	25	200	17	27	25	50	I60M5×13	WT20IP		

Applicable insert Wendeschneidplatten

Application Anwendung	Extra Finishing Feinbearbeitung	Finishing Schlichten	Semi-finishing Mittlere Bearbeit.	Roughing Schruppen	Al machining Alu Bearbeitung	Cast iron ma. Grauguss Bear.
insert shape Schneidplattenform	SF  A84	HF  A84	HM  A85	HR  A86	LH  A86	 A86
		EF  A85	EM  A85			
Type · Typ	**SCFCR06	CC**0602**	CC**0602**	CC**0602**	CC**0602**	CCGX0602**
	SCFCR09	CC09T3**	CC**09T3**	CC**09T3**	CC**09T3**	CCGX09T3**
	SCFCR12	CC1204**	CC**1204**	CC**1204**	CC**1204**	CCGX1204**

◆ Toolholder with holes for Coolant · Klemmhalter mit Kühlmittelbohrung

● ex stock · ab Lager ○ on demand · auf Anfrage

Turning · Drehen

Internal turning tools · Drehwerkzeuge zur Innenbearbeitung



CC** Toolholder · Halter

S-Clamping / S-Halter









SCLCR

Kr:95°



Type · Typ	Stock Lager		Dimension (mm) Abmessung							Screw Schraube	Wrench Schlüssel		
	R	L	Dmin	ød	L	s	a	b	e				
S10M-SCLCR06S20	●		13	10	150	7	22	20	30	I60M2.5×5.5	WT07IP		
S12P-SCLCR06S20	●		16	12	170	9	22	20	35				
S16Q-SCLCR09S20	●		20	16	180	11	22	20	40	I60M3.5×8	WT15IP		
S20R-SCLCR09S20	●		25	20	200	13	22	20	60				

Applicable insert
Wendeschneidplatten

Application Anwendung	Extra Finishing Feinbearbeitung	Finishing Schlichten	Semi-finishing Mittlere Bearbeit.	Roughing Schruppen	Al machining Alu Bearbeitung	Cast iron machining Grauguss Bearbeit.	
insert shape Schneidplattenform	SF  A84	HF  A84	HM  A85	HR  A86	LH  A86	 A86	
		EF  A85	EM  A85				
Type · Typ	**SCLCR06S20	CC**0602**	CC**0602**	CC**0602**	CC**0602**	CCGX0602**	CC**0602**
	SCLCR09S20	CC09T3**	CC**09T3**	CC**09T3**	CC**09T3**	CCGX09T3**	CC**09T3**

● ex stock · ab Lager ○ on demand · auf Anfrage ♦ Toolholder with holes for coolant · Klemhalter mit Kühlmittelbohrung



Anti Vibration Boring Bar

Anti Vibration Bohrstange

Technical features · Technische Merkmale

By increasing the rigidity of the tool materials the vibration will be reduced. The carbide toolholder performs much better than steel toolholder. The cutting data can be increased and the shank overhang extended. Therefore you achieve better surface and higher workpiece precision.

Durch den Einsatz von Hartmetall als Werkzeugmaterial wird die Stabilität des Werkzeuges verbessert, und Vibrationen werden reduziert.

Die Hartmetall-Bohrstange erlaubt durch die Stabilität höhere Schnittleistungen und eine größere Auskragung. Darüberhinaus wird eine höhere Werkstückpräzision und eine exzellente Oberflächenqualität erzielt.

Vibration amplitude · Schwingungsausschlag

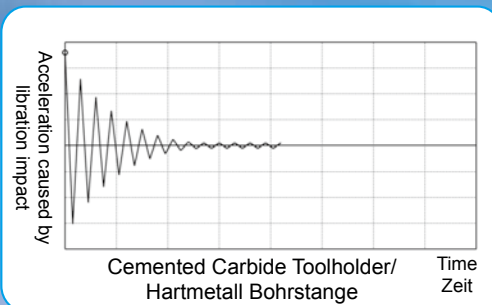
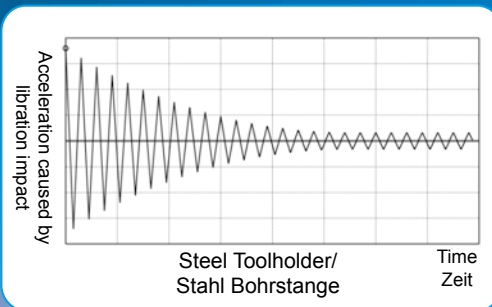

Under same machining conditions:
Bei gleichen Bearbeitungsbedingungen:

The maximum overhang of carbide toolholder is ca. $L \leq 6D$

Die maximale Auskragung beim Einsatz von Hartmetall-Bohrstangen beträgt ca. $L \leq 6D$

The maximum overhang of steel toolholder is suggested to be ca. $L \leq 3D$

Die maximale Auskragung beim Einsatz von Stahl-Bohrstangen beträgt ca. $L \leq 3D$

Turning · Drehen

Internal turning tools · Drehwerkzeuge zur Innenbearbeitung

CP** / CC** Toolholder · Halter

S-Clamping / S-Halter

SCLPR/L
SCLCR/L
Kr:95°



R type
Rechtsausführung

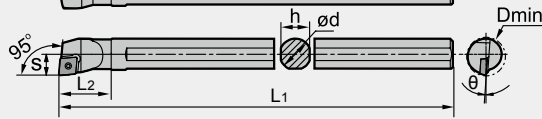

Type · Typ	Stock Lager		Dimension (mm) Abmessung							Screw Schraube	Wrench Schlüssel	Shim Unterlage	Shim/ Screw Schraube Unterlage
	R	L	ØD	ød	s	L1	L2	h	θ				
C10M-SCLPR/L06	●	●	12	10	6	150	17	9	7°	I60M2.5×5.5	WT07IP		
C12Q-SCLPR/L06	●		16	12	8	180	20	11	4°				
C16R-SCLPR/L09	●	●	20	16	10	200	29	15	4°				
C20S-SCLPR/L09	●	●	25	20	13	250	35	18	4°	I60M3.5×8	WT15IP		
◆ E16R-SCLPR/L09	○	○	19	16	10	200		15.5	-2°	I60M3.5×10	WT15IP		
◆ E20S-SCLPR/L09	○	○	24	20	13	250		19.5	-2°				
◆ E08K-SCLCR/L06-9	●	○	9	8	5	125		7.5	-12°	I60M2.5×5.5	WT07IP		
◆ E08K-SCLCR/L06-10	●	○	10	8	6	125		7.5	-12°				
◆ E10M-SCLCR/L06	●	○	12	10	7	150		9.5	-10°				
◆ E12Q-SCLCR/L06	●	○	15	12	9	180		11.5	-10°				
◆ E12Q-SCLCR/L09	●	●	15	12	9	180		11.5	-9°	I60M3.5×8	WT15IP		
◆ E16R-SCLCR/L06	●	○	18	16	10	200		15.5	-8°	I60M2.5×5.5	WT07IP		
◆ E16R-SCLCR/L09	●	●	18	16	10	200		15.5	-10°	I60M3.5×10	WT15IP		
◆ E20S-SCLCR/L09	●	●	24	20	13	250		19.5	-8°				
◆ E25T-SCLCR/L09	●	○	31	25	17	300		24	-6°				

Weitere Durchmesser auf Anfrage / more diameter on demand

Applicable insert
Wendeschneidplatten

Application
Anwendung

Extra Finishing
Feinbearbeitung

insert shape
Schneidplattenform

SF



A87

Type · Typ	Application
C*-SCLPR/L06	CP**0602**
C*--SCLPR/L09	CP**09T3**
E*-SCLCR/L06	CC**0602**
E*--SCLCR/L09	CC**09T3**

● ex stock · ab Lager ○ on demand · auf Anfrage ◆ Toolholder with holes for coolant · Klemhalter mit Kühlmittelbohrung

DP** / DC** Toolholder · Halter

S-Clamping / S-Halter

SDQPR/L
SDQCR/L
Kr:107°30'



R type
Rechtsausführung

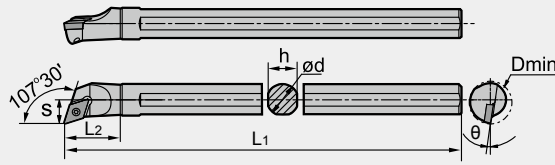

Type · Typ	Stock Lager		Dimension (mm) Abmessung							Screw Schraube	Wrench Schlüssel		
	R	L	ØD	ød	s	L1	L2	h	θ				
C10M-SDQPR/L07	●	●	13	10	7	150	20	9	8°	I60M2.5×5.5	WT07IP		
C12Q-SDQPR/L07		●	16	12	9	180	22	11	8°				
C16R-SDQPR/L07	●		20	16	11	200	27	15	6°				
C16R-SDQPR/L11	●	●	20	16	11	200	32	15	6°	I60M3.5×8	WT15IP		
C20S-SDQPR/L11	●		25	20	13	250	33	18	6°				
◆ E08K-SDQCR/L07	●	○	11	8	6.5	140		7.5	-12°	I60M2.5×5.5	WT07IP		
◆ E10M-SDQCR/L07	●	○	12	10	7	150		9.5	-10°				
◆ E12Q-SDQCR/L07	●	○	15	12	9	180		11.5	-10°				
◆ E16R-SDQCR/L07	●	○	18	16	10	200		15.5	-6°				
◆ E16R-SDQCR/L11	●	○	18	16	10	200		15.5	-8°				
◆ E20S-SDQCR/L07	●	○	24	20	13	250		19.5	-4°				
◆ E20S-SDQCR/L11	●	○	24	20	13	250		19.5	-8°				
◆ E25T-SDQCR/L11	○	○	31	25	17	300		24	-6°	I60M3.5×10	WT15IP		

Weitere Durchmesser auf Anfrage / more diameter on demand

Applicable insert
Wendeschneidplatten

Application
Anwendung

Extra Finishing
Feinbearbeitung

insert shape
Schneidplattenform

SF



A93

Type · Typ	Application Anwendung	Extra Finishing Feinbearbeitung
C*-SDQPR/L07		DP**0702**
C*-SDQPR/L11		DP**11T3**
E*-SDQCR/L07		DC**0702**
E*-SDQCR/L11		DC**11T3**

◆ Toolholder with holes for Coolant · Klemmhalter mit Kühlmittelbohrung

● ex stock · ab Lager ○ on demand · auf Anfrage

Turning · Drehen

Internal turning tools · Drehwerkzeuge zur Innenbearbeitung

DP** / DC** Toolholder · Halter

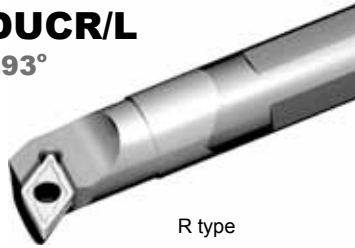

S-Clamping / S-Halter

SDUPR/L
SDUCR/L
Kr:93°

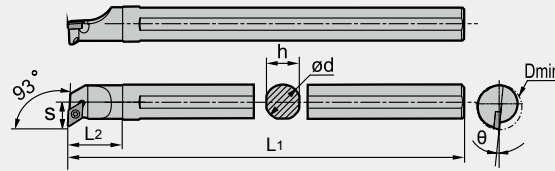

R type
Rechtsausführung



Type · Typ	Stock Lager		Dimension (mm) Abmessung							Screw Schraube	Wrench Schlüssel		
	R	L	ØD	ød	s	L1	L2	h	θ				
C10M-SDUPR/L07	●	●	15	10	9	150	18	9	8°	I60M2.5×5.5	WT07IP		
C12Q-SDUPR/L07	●	●	16	12	9	180	19	11	8°	I60M2.5×6.5			
C16R-SDUPR/L07	●	●	20	16	11	200	25	15	6°	I60M2.5×6.5			
◆ E10M-SDUCR/L 07	●	○	12	10	7	150		9.5	-10°	I60M2.5×5.5	WT07IP		
◆ E12Q-SDUCR/L 07	●	○	15	12	9	180		11.5	-10°				
◆ E16R-SDUCR/L 07	●	○	18	16	10	200		15.5	-6°	I60M3.5×10	WT15IP		
◆ E16R-SDUCR/L 11	●	○	18	16	10	200		15.5	-8°				
◆ E20S-SDUCR/L 07	○	○	24	20	13	250		19.5	-4°	I60M2.5×5.5	WT07IP		
◆ E20S-SDUCR/L 11	○	○	24	20	13	250		19.5	-8°	I60M3.5×10	WT15IP		
◆ E25T-SDUCR/L 11	○	○	31	25	17	300		24	-6°				

Weitere Durchmesser auf Anfrage / more diameter on demand

Applicable insert
Wendeschneidplatten

Application
Anwendung

Extra Finishing
Feinbearbeitung

insert shape
Schneidplattenform

SF



A93

Type · Typ	C*-SDUPR/L07	DP**0702**
	E*-SDUCR/L07	DC**0702**
	E*-SDUCR/L11	DC**11T3**

● ex stock · ab Lager ○ on demand · auf Anfrage ◆ Toolholder with holes for coolant · Klemhalter mit Kühlmittelbohrung

TP** Toolholder · Halter

S-Clamping / S-Halter

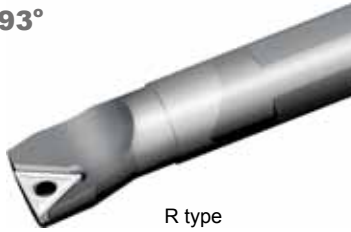

STUPR/L

Kr:93°

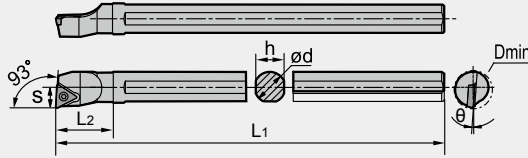

R type
Rechtausführung



Type · Typ	Stock Lager		Dimension (mm) Abmessung							Screw Schraube	Wrench Schlüssel		
	R	L	ØD	ød	s	L ₁	L ₂	h	θ				
C10M-STUPR/L09	●	●	12	10	6	150	20	9	6°	I60M2.2×5.5	WT071P		
C12Q-STUPR/L09	●		16	12	8	180	22	11	4°				
C12Q-STUPR/L11	●		16	12	8	180	25	11	4°	I60M2.5×6.5	WT071P		
C16R-STUPR/L11	●		20	16	10	250	27	15	3°				

Applicable insert
Wendeschneidplatten

Application
Anwendung

Extra Finishing
Feinbearbeitung

insert shape
Schneidplattenform

SF



A103

Type Typ	C*-STUPR/L09	TP**0902**
	C*-STUPR/L11	TP**1103**

◆ Toolholder with holes for Coolant · Klemmhalter mit Kühlmittelbohrung

● ex stock · ab Lager ○ on demand · auf Anfrage

TC** Toolholder · Halter

S-Clamping / S-Halter

STFCR/L

Kr:90°

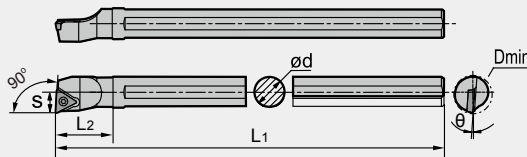

Type · Typ	Stock Lager		Dimension (mm) Abmessung							Screw Schraube	Wrench Schlüssel		
	R	L	ØD	ød	s	L ₁	L ₂	h	θ				
♦ E08K-STFCR/L 09	○	○	11	8	6	125		7.5	-12	I60M2.2×5.5	WT07IP		
♦ E10M-STFCR/L 09	○	○	12	10	7	150		9.5	-10				
♦ E12Q-STFCR/L 11	○	○	15	12	9	180		11.5	-10	I60M2.5×5.5	WT07IP		
♦ E16R-STFCR/L 11	○	○	18	16	10	200		15.5	-8				
♦ E20S-STFCR/L 11	○	○	24	20	13	250		19.5	-8	I60M3.5×10	WT15IP		
♦ E20S-STFCR/L 16	○	○	24	20	13	250		19.5	-8				
♦ E25T-STFCR/L 16	○	○	31	25	17	300		24	-6	I60M3.0×7.0	WT08IP		
♦ E10M-STFPR/L 11	○	○	12	10	6	150		9.5	-5				
♦ E12Q-STFPR/L 11	○	○	15	12	8	180		11.5	-4	I60M3.0×7.0	WT08IP		
♦ E16R-STFPR/L 11	○	○	19	16	10	200		15.5	-2				
♦ E20S-STFPR/L 11	○	○	24	20	13	250		19	-2				

Weitere Durchmesser auf Anfrage / more diameter on demand

Applicable insert
Wendeschneidplatten

Application
Anwendung

Extra Finishing
Feinbearbeitung

insert shape
Schneidplattenform

SF



A98

Type Typ	E*-STFCR/L09	TC**0902**
	E*-STFCR/L11	TC**1103**
	E*-STFCR/L16	TC**16T3**
	E*-STFPR/L11	TP**1103**

VC** Toolholder · Halter

S-Clamping / S-Halter



SVQCR/L

Kr:107°30'



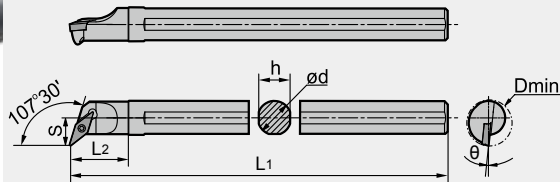

R type
Rechtsausführung



Type · Typ	Stock Lager		Dimension (mm) Abmessung							Screw Schraube	Wrench Schlüssel		
	R	L	ØD	ød	s	L1	L2	h	θ				
C16R-SVQCR/L11	●	●	22	16	13	200	28	15	-6°	I60M2.5×6.5	WT07IP		
C20S-SVQCR/L11	●	●	26	20	15	250	32	18	-4°				

Applicable insert
Wendeschneidplatten

Application Anwendung	Extra Finishing Feinbearbeitung	Finishing Schlichten	Al machining Alu Bearbeitung	
insert shape Schneidplattenform	SF  A106	HF  A106	LH  A107	
Type · Typ	C*-SVQCR/L11	VC**1103**	VC**1103**	VCGX1103**
	C*-SVUCR/L11	VC**1103**	VC**1103**	VCGX1103**

Turning · Drehen

Internal turning tools · Drehwerkzeugen zur Innenbearbeitung

VC** Toolholder · Halter

S-Clamping / S-Halter

SVUCR/L

Kr:93°



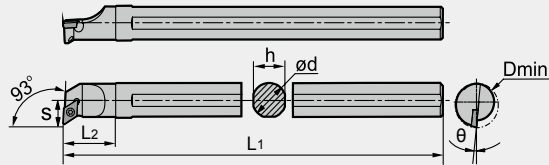

R type
Rechtsausführung



Type · Typ	Stock Lager		Dimension (mm) Abmessung							Screw Schraube	Wrench Schlüssel		
	R	L	ØD	ød	s	L ₁	L ₂	h	θ				
C16R-SVUCR/L11	●	●	24	16	15	200	25	15	6°	I60M2.5×6.5	WT07IP		
C20S-SVUCR/L11	●	●	28	20	17	250	30	18	4°				
◆ E16R-SVUCR/L 11	○	○	22	16	13	200		15	-6.5°	I60M2.5×6.5	WT07IP		
◆ E20S-SVUCR/L 11	○	○	27	20	13	250		18	-6.5°				
◆ E25T-SVUCR/L 16	○	○	35	25	20.5	300		23	-6.5°	I60M3.5×10	WT15IP		

Weitere Durchmesser auf Anfrage / more diameter on demand

Applicable insert
Wendeschneidplatten

Application Anwendung	Extra Finishing Feinbearbeitung	Finishing Schlichten	Al machining Alu Bearbeitung
insert shape Schneidplattenform	SF  A106	HF  A106	LH  A107
Type · Typ	C*-SVUCR/L11	VC**1103**	VC**1103**
	E*-SVUCR/L11	VC**1103**	VC**1103**
			VCGX1103**
			VCGX1103**

● ex Stock Lager · ab Lager ○ on demand · auf Anfrage

◆ Toolholder with wholes for Coolant · Klemhalter mit Kühlmittelbohrung

■ Recommended cutting data · Empfohlene Schnittdaten

ISO	Workpiece Materials Werkstückstoff		Hardness · Härte HB	CVD Coating · Beschichtung					PVD Coating · Beschicht.			Cermet	Coated cermet	Cemented carbide/ unbe. Hartmetall		Ceramic Keramik			
				YBC151	YBC251	YBC152	YBC252	YBC351	YBG102	YBG202	YBG302	YNG151	YNG151C	YC10	YC40	CA1000	CN2000		
				Feed rate · Vorschub (mm/rev)															
				0.1-0.6	0.1-0.8	0.1-0.6	0.1-0.8	0.2-1.0	0.2-0.4	0.1-0.6	0.05-0.8	0.05-0.2	0.05-0.2	0.1-0.4	0.1-0.5	0.1-1.5	0.1-1.5		
Cutting speed · Schnittgeschwindigkeit (m/min)																			
P	Carbon steel Kohlenstoffstahl	C=0.15%	125	430-200	430-190	500-270	480-240	380-165	460-220	380-180	360-165	550-350	580-350	360-165	300-145	800-300			
		C=0.35%	150	380-180	410-180	460-250	460-230	300-150	440-210	300-170	280-150	500-300	520-300	280-150	220-130	600-200			
		C=0.60%	200	330-150	350-150	400-220	400-200	260-130	380-180	260-150	240-130	460-260	480-260	240-130	180-80	400-150			
	Alloy steel legierter Stahl	low alloy, annealed geglüht	180	350-170	350-150	400-180	400-200	200-100	380-180	200-120	180-100	410-240	430-240	180-100	160-80	150-180	400-150		
		low alloy, tempered vergütet	275	230-100	210-100	280-150	260-140	140-70	240-120	140-90	120-70	300-180	320-180	120-70	120-50	350-120	300-100		
		low alloy, tempered vergütet	300	210-100	190-70	260-150	240-120	125-60	220-100	125-80	100-60	250-170	270-170	100-60	80-40	300-100	250-80		
		low alloy, tempered vergütet	350	180-80	170-70	230-120	220-120	110-55	200-100	110-75	90-55	230-150	250-150	90-55	70-45	300-80			
	High alloy steel Hochlegierter	high alloy, annealed geglüht	200	320-150	260-120	360-190	310-170	175-80	290-150	175-100	155-80	350-200	370-200	155-80	135-60	400-150	350-120		
		high alloy, tempered vergütet	325	140-90	100-50	190-130	150-100	85-40	130-80	85-60	65-40	170-110	190-110	65-40	45-30	300-100	280-80		
	Cast steel Stahlguß	Non-Alloy unlegiert	180	240-120	200-100	280-160	250-140	135-75	230-125	135-95	115-75	260-170	280-170	115-75	95-55	600-220			
Low alloy niedrig legiert		200	230-70	170-60	280-110	220-110	120-80	200-90	120-100	100-80	260-170	280-170	100-80	80-60	400-150				
High alloy hoch legiert		225	160-70	140-50	210-110	190-100	95-55	170-80	95-55	95-55	260-100	280-100	95-55	75-35	350-120				
ISO	Workpiece Materials Werkstückstoff		Hardness · Härte HB	CVD Coating · Beschichtung					PVD Coating · Beschicht.			Cermet	Coated cermet						
				YBM151	YBM251				YBG202	YBG302		YNG151	YNG151C						
				Feed rate · Vorschub (mm/rev)															
				0.2-0.6	0.2-0.6				0.1-0.4	0.2-0.6		0.1-0.3	0.1-0.3						
Cutting speed · Schnittgeschwindigkeit (m/min)																			
M	Stainless steel Rostfreier Stahl	Ferrite	180	280-180	250-140				300-190	250-150		330-220	350-210						
		Austenite	260	250-150	200-110				250-160	220-120		250-150	270-140						
		Martensite	330	200-140	210-130				260-170	210-120		270-170	290-160						

Turning · Drehen

Application Information · Anwendungsinformation

Recommended table of cutting parameters for general turning Empfohlene Schnittparameter für allgemeine Drehbearbeitung

ISO	Workpiece Materials Werkstückstoff		Hardness · Härte HB	CVD Coating · Beschichtung					Cermet	Coated cermet	Ceramic Keramik			Cemented carbide/ unbe. Hartmetall		
				YBD052	YBD151	YBD102	YBD152	YBD252			YNG151	YNG151C	CA1000	CN1000	CN2000	YC10
				Feed rate · Vorschub (mm/rev)												
				0.1-0.4	0.1-0.6	0.1-0.4	0.1-0.5	0.1-0.8	0.1-0.4	0.1-0.4	0.1-1.5	0.1-1.5	0.1-1.5	0.1-0.3	0.1-0.4	
Cutting speed · Schnittgeschwindigkeit (m/min)																
K	Malleable cast iron Temperguss	Ferrite	130	350-230	315-210	330-220	320-105	250-170	280-160	300-180	1200-200	800-600	800-600	150-90	105-45	
		Pearlite	230	250-105	225-95	230-100	230-100	180-75	220-120	240-150	1000-200	700-500	700-500	120-70	80-30	
	Low cast iron Grauguss	180	520-200	450-180	480-200	480-190	380-150	400-250	420-270	1200-200	800-600	700-500	170-100	130-60		
	High cast iron Grauguss	260	230-120	210-110	220-115	210-100	170-90	360-240	380-260	1000-200	750-500	800-600	130-70	95-40		
	Nodular cast iron	Ferrite	160	310-150	285-140	300-150	290-140	220-110	330-190	350-210	800-200	600-450	600-450	140-80	115-45	
		Pearlite	250	230-110	210-100	220-105	210-100	170-90	310-200	330-220	700-200	500-350	500-350	110-70	80-30	
ISO	Workpiece Materials Werkstückstoff		Hardness · Härte HB	PVD Coating · Beschichtung		Cemented carbide Hartmetall	CBN		PCD PKD							
				YBG102			YD101	YCB011		YCB012	YCD011					
				Feed rate · Vorschub (mm/rev)												
				0.05-0.15		0.05-0.35	0.05-0.5	0.05-0.2	0.05-0.5							
Cutting speed · Schnittgeschwindigkeit (m/min)																
N	Al alloy Al Legierung	No heat treatment keine Wärmebeh.	60			1750-800			2500-							
		Heat treatment	100			510-250			2500-							
	Cast aluminum alloy Alu. leg.	No heat treatment keine Wärmebeh.	75			460-175			2500-							
		Heat treatment keine Wärmebeh.	90			300-110			2500-							
	Copper alloy Kupfer leg.	Lead alloy keine Wärmebeh.	110			610-205			630-65							
		Copper, pure copper	90			310-195			630-65							
	Copper, nonleaded Copper, electrolytic copper	100			225-115			375-30								
S	Ni-base alloy	Ni-base alloy	40	90-30		70-20										
H	Other materials Andere Materialien	Hard steel	45 HRC					350-225								
		Super hard steel	50~60 HRC					250-135								
		Chilled cast iron	500			180-120										

■ Correctional cutting parameters table of internal turning Schnittparameter Übersicht zur Drehinnenbearbeitung

Internal turning tools by P type clamping · Drehwerkzeuge (Innen) P Typ Klemmung

	Workpiece material Werkstück Material	Hardness HB Härte	Machining category Anwendung	L/D≤3		L/D=3-4 (Diameter of shank≥Φ16mm)	
				Feed rate Vorschub (mm/rev)	Cutting depth Schnitttiefe (mm)	Feed rate Vorschub (mm/rev)	Cutting depth Schnitttiefe (mm)
P	Carbon steel, Alloy steel Kohlenstoff Stahl, Stahlleg. 45#, 42CrMo	HB180—280	Semi-finishing Mittlere Bear.	0.1- 0.25 -0.4	<5.0	0.1- 0.2 -0.3	<4.0
M	Stainless steel Rostfreier Stahl 1Cr18Ni9Ti 0Cr18Ni9	≤HB220	Semi-finishing Mittlere Bear.	0.1- 0.2 -0.3	<4.0	0.1- 0.15 -0.25	<3.0
K	Cast iron HT250 Gusseisen	HB170—230	Semi-finishing Mittlere Bear.	0.1- 0.25 -0.4	<5.0	0.1- 0.2 -0.3	<4.0

Internal turning tools by S type clamping · Drehwerkzeuge (Innen) S Typ Klemmung

	Workpiece material Werkstück Material	Hardness HB Härte	Machining category Anwendung	L/D≤3		L/D=4		L/D=5		L/D=6	
				Feed rate Vorschub (mm/rev)	Cutting depth (mm)	Feed rate Vorschub (mm/rev)	Cutting depth (mm)	Feed rate Vorschub (mm/rev)	Cutting depth (mm)	Feed rate Vorschub (mm/rev)	Cutting depth (mm)
P	Carbon steel, Alloy steel Kohlenst. Stahl, leg. Stahl 45#, 42CrMo	HB180-280	For finishing Schlichten	0.05- 0.1 -0.15	<0.2	0.05- 0.1 -0.15	<0.2	-	-	-	-
			For semi-finishing Mittlere Bear.	0.15- 0.25 -0.35	<3.0	0.1- 0.15 -0.2	<1.5	-	-	-	-
M	Stainless steel Rostfreier Stahl 1Cr18Ni9Ti 0Cr18Ni9	≤HB220	For finishing Schlichten	0.05- 0.1 -0.15	<0.2	0.05- 0.1 -0.15	<0.2	-	-	-	-
			For semi-finishing Mittlere Bear.	0.15- 0.2 -0.25	<2.0	0.1- 0.15 -0.2	<1.0	-	-	-	-
N	Al Alloy	---	For finishing Schlichten	0.05- 0.1 -0.15	<0.2	0.05- 0.1 -0.15	<0.2	0.05- 0.1 -0.15	-0.15	0.05- 0.1 -0.15	<0.1
			For semi-finishing Mittlere Bear.	0.05- 0.1 -0.15	<2.0	0.05- 0.1 -0.15	<1.5	0.05- 0.1 -0.15	-1.0	0.05- 0.1 -0.15	<1.0

Antivibration internal turning tools · Antivibrations Drehwerkzeuge (Innen)

	Workpiece material	Machining conditions Anwendung	Chipbreaker Spanbrecher	Grade Sorte	Feed rate Vorschub (mm/rev)	Cutting depth Schnitttiefe (mm)
P	Steel HB180—280 Stahl	Finishing Schlichten	SF	YNG151 YNG151C	0.05- 0.2 -0.35	0.05- 0.1-0.3 -0.5
M	Stainless steel ≤HB220 Rostfreier Stahl				0.05- 0.2 -0.35	0.05- 0.1-0.3 -0.5
K	Cast iron HB170—230 Gusseisen				0.05- 0.2 -0.35	0.05- 0.1-0.3 -0.5

Letters in blue color are recommended cutting parameters

Turning · Drehen

Application information · Anwendungsinformation

A

General Turning · Allgemeine Drehbearbeitung

No.	Tool wear type	Situation	Reason	Countermeasures
1+2	Flank wear	Poor surface quality and inconsistent measurement. Increase in cutting force.	Grade is too soft Cutting speed is too high. Flank angle is too small. Feed rate is too low	Select grade with higher wear resistance Reduce cutting speed Increase flank angle. Increase feed rate
3	Crater wear	Bad surface and chip control	Grade is too soft. Cutting speed is too high. Feed rate is too high.	Select grade with higher wear resistance Reduce cutting speed Reduce feed rate
4	Chipping	Tool life not stable Sudden breakage of cutting edge	Grade is too hard. Feed rate is too high. Cutting edge strength not strong enough The rigidity of holder is insufficient (vibration)	Select grade with higher toughness Reduce feed rate Change honing of cutting edge Use holder with bigger shank size
5	Fracturing	Cutting force increasing Surface roughness and measure becomes bad	Grade is too hard. Feed rate is too high. Cutting edge strength not strong enough The rigidity of holder is insufficient	Select grade with higher toughness Reduce feed rate Change honing of cutting edge Use holder with bigger shank size
6	Plastic deformation	Inconsistent measure meet. Damage to the cutting edge	Grade is too soft. Cutting speed is too high. Depth of cut and feed rate too high Cutting temperature is high	Grade with high wear resistance. Reduce cutting speed Decrease depth of cut and feed rate. Grade with high thermal conductivity.
7	Welding	Poor surface quality and inconsistent measurement. Increase in cutting force.	Cutting speed is low. Cutting edge not sharp enough Grade not suitable	Increase cutting speed Increase rake angle. Select grade with lower affinity
8	Thermal Cracks	Break due to thermal variation effect often caused when cutting is interrupted.	Expansion or shrinkage due to cutting heat Grade is too hard.	Use dry cutting Select grade with higher toughness
9	Notch wear	Burr increase of Cutting force information	Unstable cutting condition (uncut surface, chilled parts, machining hardened layer) Friction caused by jagged shape chips. Feed rate and cutting speed too high	Grade with high wear resistance. Increase rake angle to improve sharpness Decrease cutting speed
10	Flaking	Mostly happens during machining of high hard materials or vibration	Cutting edge welding and adhesion. Bad chip removing	Increase rake angle to improve sharpness Use chip breaker with wider chip pocket



Bild	Art des Verschleißes	Auswirkungen	Grund	Gegenmaßnahmen
1+2	Freiflächenverschleiß	Schlechte Oberflächengüte und Maßhaltigkeit Anstieg der Schnittkraft	Sorte nicht verschleißfest genug Schnittgeschwindigkeit zu hoch Freiwinkel zu klein Vorschub zu gering	Sorte mit höherer Verschleißfestigkeit Schnittgeschwindigkeit reduzieren Freiwinkel vergrößern Vorschub reduzieren
3	Kolkverschleiß	Schlechte Oberflächengüte und Spankontrolle	Sorte nicht verschleißfest genug Schnittgeschwindigkeit zu hoch Vorschub zu hoch	Sorte mit höherer Verschleißfestigkeit Schnittgeschwindigkeit reduzieren Vorschub reduzieren
4	Ausbröckelung	Standzeit nicht stabil Plötzlicher Bruch der Schneidkante	Sorte ist zu hart Vorschub zu hoch Schneidkantenstabilität nicht ausreichend Stabilität des Werkzeughalter oder Spannung nicht ausreichend	Sorte mit höherer Zähigkeit Vorschub reduzieren Schneidkantenverrundung ändern Stabileren Halter verwenden
5	Bruch	Anstieg der Schnittkraft Schlechte Oberflächengüte und Maßhaltigkeit	Sorte ist zu hart Vorschub zu hoch Schneidkantenstabilität nicht ausreichend Stabilität des Werkzeughalter oder Spannung nicht ausreichend	Sorte mit höherer Zähigkeit Vorschub reduzieren Schneidkantenverrundung ändern Stabileren Halter verwenden
6	Plastische Deformation	Schlechte Maßhaltigkeit Beschädigung der Schneidkante	Sorte nicht verschleißfest genug. Schnittgeschwindigkeit zu hoch Schnitttiefe und/oder Vorschub zu hoch Temperatur an der Schneide zu hoch	Sorte mit höherer Verschleißfestigkeit Schnittgeschwindigkeit reduzieren Schnitttiefe und Vorschub reduzieren Sorte mit höherer Wärmebeständigkeit
7	Aufbauschneide	Anstieg der Schnittkraft Schlechte Oberflächengüte	Schnittgeschwindigkeit zu niedrig Schneidkante nicht scharf genug Sorte nicht geeignet	Schnittgeschwindigkeit erhöhen Spanwinkel erhöhen Sorte mit geringer Affinität
8	Thermischer Verschleiß	Bruch durch thermische Wechselwirkung Oft bei unterbrochenem Schnitt (Fräsen)	Durch die Bearbeitungs- Temperaturschwankungen Sorte ist zu hart	Trockenbearbeitung Sorte mit höherer Zähigkeit
9	Kerbverschleiß	Gratbildung Anstieg der Schnittkraft	Beschädigung durch Späne (ausgefranzte Spankante) Vorschub und Schnittgeschwindigkeit zu hoch	Sorte mit höherer Verschleißfestigkeit Spanwinkel vergrößern um eine schärfere Schneide zu bekommen Schnittgeschwindigkeit verringern
10	Abplatzung (Beschichtung)	Oft bei der Bearbeitung härterer Werkstoffe oder wenn Vibrationen auftauchen	Verklebungen an der Schneidkante sowie Ausbrüche. Schlechte Spanabfuhr	Spanwinkel vergrößern um eine schärfere Schneide zu bekommen Spanbrecher mit größerer Spankammer

Turning · Drehen

Parting and Grooving · Ab- & Einstechen

Parting and grooving tools overview · Ab- & Einstechen Übersicht **A255-A257**

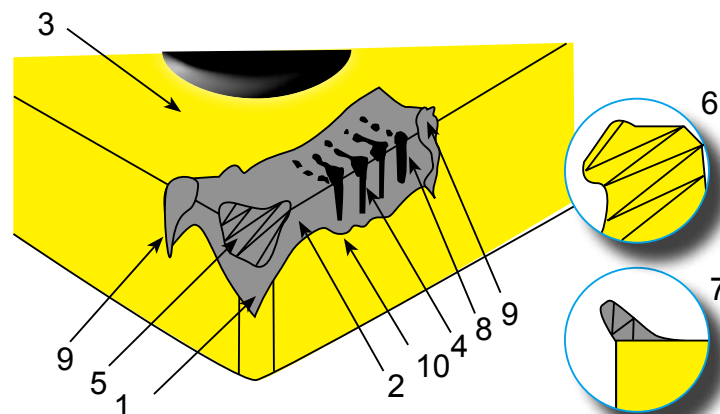
Parting and grooving inserts · Abstech- und Einstechplatten **A258-A268**

Chip breaker introduction of "Squirrel Series" inserts A258-A259
Spanbrecher der Einsätze von der "Squirrel Serie"

Parting, grooving and profiling inserts code key A260
Ab- & Einstechplatte ISO Kennzeichen

Inserts of · Stechplatten der "Squirrel Serie" A261-A266

154.3 Series A267

ZQMX series A267

ZSMF·ZSMX series A268

Parting and grooving tools · Ab- & Einstechwerkzeuge "Squirrel Series" **A269-A287**

parting and grooving tools code key · Ab- & Einstechwerkzeuge A269-A270

External parting, grooving and turning tools · Ab- & Einstechwerkzeuge (Außen) A271-A271

Precise grooving and turning tools · Präzisions Einstech- & Drehwerkzeuge A273

External recess and profiling tools · Hinterdrehstech- & Profildrehwerkzeuge (Außen) A273

External grooving tools for difficult machining A274
Stechdrehwerkzeuge für die schwierige Bearbeitung (Außen)

External parting blade & holder for external parting A275
Abstech-Schwert zur Außenbearbeitung & Spannblock zur Außenbearbeitung

Axial grooving and turning tools · Axial Einstech- & Drehwerkzeuge A276-A283

Internal grooving and turning tools · Ab- & Einstechwerkzeuge (Innen) A284

Profiling and turning tools for Al. · Profil- & Drehwerkzeuge (Aluminium) A284

Complementary series · Erweiterende Serie A285-A288

Complementary Series parting and grooving tools Code Key A285
Erweiternde Serie Ab- & Einstechwerkzeug ISO Kennzeichen

















QZQ External grooving Series · Außenstechserie A286

QZS Internal grooving Series · Innenstechserie A286

QZS External grooving Series · Außenstechserie A287









QT External grooving · Außenstechserie A288

Application information of parting and grooving **A289-A290**
Anwendungsinformation für Ab- & Einstechen

Machining application	Machining Bearbeitung	Toolholder Klemmhalter	Inserts Stechplatten	Tool's feature and parameters Werkzeug Eigenschaften & Parameter	
External machining · Außenbearbeitung	Parting · Abstechen	"Squirrel Series" QZ**+QE**  A275	ZP*S** 	<ul style="list-style-type: none"> Assemble structure of parting blade and holder, good rigidity and parting range is adjustable. The max. parting $\varnothing = 120\text{mm}$. Die Auskrägung des Abstech-Swertes ist bei hoher Stabilität einstellbar Der max. Abstech $\varnothing = 120\text{mm}$ 	
		"Squirrel Series" QE**R/L  A272	ZP**D*  ZP*S* 	<ul style="list-style-type: none"> Inserts have 3d chip breaker, small cutting force, good performance on chip breaking maximum parting $\varnothing = 60\text{mm}$ Schneideinsatz mit 3 versch. Spanleitstufen für geringe Schnittkräfte & gute Spankontrolle. max. Abstech $\varnothing = 120\text{mm}$ 	
		Complementary series QZQ*R/L  A286	ZQMX** 	<ul style="list-style-type: none"> Cutting edge strength is suitable for bad machining conditions The maximum parting $\varnothing = 70\text{mm}$ Stabile Schneidkante für den Einsatz bei ungünstigen Bearbeitungsbedingungen Der max. Abstech $\varnothing = 70\text{mm}$ 	
	Grooving and turning Stechen und Drehen	 A247	"Squirrel Series" QE*R/L  A247	Double / Doppelseitig ZT*D**  Profile turning/ Profildrehen ZR*D*  Single cutting edge for deep grooving/ Einseitig ZT*S* 	<ul style="list-style-type: none"> Various applications can be realised by one single tool, installed with different inserts for grooving, profiling and parting, It reduces the tool category. Installed with grooving inserts, the tool realises grooving and transverse cutting. This tool is multifunctional. The max. slot depth = 30mm. Bei Anwendung dieses Universal WZ-System und Verwendung der unterschiedlichen Schneideinsätze können die Bearbeitungen wie; Ab-, Stechen, Profil-, Drehen druchgeführt werden Die max. Nutentiefe = 30mm
			"Squirrel Series" QECD  A273	Precise grooving/ Präzisionsstechen ZT*D**-EG  Edge width 1.2~2.4mm	<ul style="list-style-type: none"> Grinded insert, used for precise grooving. Edge width can be any size between 1.0-6.5mm according to customers requirement. ZT*D**-EG inserts: When edge width is between 1.2-2.4mm, the maximum cutting depth is 2.5mm; When edge width is >2.4~6.5mm, the maximum cutting depth is 22mm
	Precise grooving · Präzisionsstechdrehen	 A272	"Squirrel Series" QE*R/L  A272	Precise grooving/ Präzisionsstechen ZT*D**-EG  Edge width 1.2~2.4mm Stechbreite	<ul style="list-style-type: none"> geschliffene Einsätze für das Präzisionsstechen Die Schneidenbreite kann auf Wunsch zwischen 1.0-6.5mm geschliffen werden. ZT*D**-EG Stechplatte: bei S.-Breiten von 1.2-2.4mm, und max. Schnitttiefe von 2.5mm; bei S.-Breiten von >2.4~6.5mm, beträgt die max Schnitttiefe 22mm

Turning · Drehen

Parting & Grooving Overview · Ab- & Einstechen Übersicht

Machining application	Machining Bearbeitung	Toolholder Klemmhalter	Inserts Stechplatten	Tool's feature and parameters Werkzeug Eigenschaften & Parameter
External Machining Außenbearbeitung	Grooving Stechen	Complementary series QZS**R/L  A287	ZSMF** 	<ul style="list-style-type: none"> Fine grinded inserts, high precision Cutting edge can be machined 1.1-5.0mm The max. depth of slot = 6mm Geschliffene Einsätze für hohe Präzision Schneidenbreite zwisch. 1,1-5,0mm Die max. Stechtiefe = 6 mm
		Complementary series QT*R/L  A288	154.3** 154.3** 	<ul style="list-style-type: none"> Top and hole clamping Sharp cutting edge, uneasy to shake 3 fine grinded cutting edge, good economic character Used for grooving, the slot width = 1.1-5.5mm The max. cutting depth = 5mm Pratzen- & Lochklemmung Scharfe Schneidkante 3 feingeschliffene Schneidkanten Beim Einstechen beträgt die max. Nutenbreite zwisch. 1,1 - 5,5 mm Die max. Schnitttiefe = 5 mm
Internal machining · Innenbearbeitung	Grooving and turning Stechen und Drehen	"Squirrel Series" C*-Q*R/L*  A284	Grooving, Turning Stechen, Drehen ZT*D**  Profile turning ZR*D** 	<ul style="list-style-type: none"> By installing different inserts for grooving & profiling, one single tool realizes various applications, it reduce the tool category. The max. slot depth can be machined = 13mm The min Ø can be machined = 27 mm Ein W-System für Stech- & Profildrehen. Die Anzahl der Stechsysteme wird reduziert. Die max. Nutentiefe = 13 mm Der min. Ø = 27 mm
	Grooving Stechen	Complementary Series C*-QZSR/L*  A287	Grooving/ Stechen ZSMF**R/L 	<ul style="list-style-type: none"> Fine grinded inserts, high precision Slot width can be machined is 1.1-5.0mm The min. Ø can be machined = 20mm The max. slot depth can be machined = 6 mm Fein geschliffener Einsatz für hohe Präzision Nutentiefe beträgt 1,1-5 mm Der min. Ø = 20 mm Die max Nutentiefe = 6 mm

Turning · Drehen

Parting & Grooving Overview · Ab- & Einstechen Übersicht

Machining application	Machining Bearbeitung	Toolholder Klemmhalter	Inserts Stechplatten	Tool's feature and parameters Werkzeug Eigenschaften & Parameter
Axial Grooving Axial stechen	Grooving and turning Stechen und Drehen	 <p>"Squirrel Series" QF**H A278-A281</p>	Grooving, Turning Stechen, Drehen ZT*D**  Profile turning ZR*D** 	<ul style="list-style-type: none"> By installing different inserts as for grooving and profiling, one single tool realizes various applications, it reduces the tool category. Grooving · Stech Ø 48-400mm Grooving depth · Nuttiefe 10-30mm Ein W-System für Stech- & Profildrehen. Die Anzahl der Stechsysteme wird reduziert.
		 <p>"Squirrel Series" QF**L A282-A283</p>	Grooving, Turning ZT*D**  Profile turning ZR*D** 	<ul style="list-style-type: none"> 90° toolholder, top clamping By installing different inserts as for grooving and profiling, one single tool realizes various applications, it reduce the tool category. Grooving · Stech Ø 48-400mm Grooving depth · Nuttiefe 10-30mm Ein W-System für Stech- & Profildrehen. Die Anzahl der Stech-systeme wird reduziert. 90° Klemmhalter, Pratzenklemmung
Recess Machining Hinterstechen	Recess and turning Hinterstech. und drehen	 <p>"Squirrel Series" *X*D* A273</p>	Grooving, Turning ZT*D**  Profile turning ZR*D** 	<ul style="list-style-type: none"> The unique tool for recess machining Variing recess machining can be realized, inserts programm is complete Ein W-System für Hinterstechdrehen Unterschiedliche Hinterdreheroperationen können durchgeführt werden. Das Einsatzprogramm ist komplett.
Alu profiling Aluminium Profildrehen	External mach. Außenbearbeit.	 <p>"Squirrel Series" QE**R/L A272</p>	"Squirrel Series" ZR**-LH 	<ul style="list-style-type: none"> The unique chip breaker for profiling Al material Cutting edge is designed as combination of sharpness and stability, and it's suitable for continuous to intermittent cut. Used for for external, surface and inner wall machining of Al wheelboss. Spezielle Spanbrecher für die Alu Bearbeitung. Schneidkante besitzt Schärfe und Stabilität für kontinuierlichen bis unterbrochenem Schnitt. Profildrehen, von Alu. Felgen
	Inner wall and surface machining Plan- & Längsprofildrehen	 <p>"Squirrel Series" C40X* A284</p>		<ul style="list-style-type: none"> Used for for external, surface and inner wall machining of Al wheelboss. Spezielle Spanbrecher für die Alu Bearbeitung. Schneidkante besitzt Schärfe und Stabilität für kontinuierlichen bis unterbrochenem Schnitt. Profildrehen, von Alu. Felgen
Tools for aviation and aerospace industries Werkzeuge für die Raum- & Luftfahrt	External machining Außenbearbeitung	 <p>"Squirrel Series" QE*S*N A274</p>	"Squirrel Series" ZIGQ**  "Squirrel Series" ZIMF** 	<ul style="list-style-type: none"> V type locating, top clamping, precisely locating, safely clamping Inserts are suitable for difficult to machine materials like: Ni-base, Ti alloy, Stainless steel and Exotic material. V Form Aufnahme, Top Klemmung für Präzisions-Einsatz, Fixierung & sichere Klemmung Stechplatte für schwierig zu zerspanende Werkstoffen wie: Ni-base, Ti alloy, Stainless steel and exotic material.
	Non-standard Tools Sonderwerkzeug	 <p>Non-Standard tools , Sonderwerkzeug</p>	Select and manufacture according to requirement. Auswahl nach Anwendung	<ul style="list-style-type: none"> Instantly supply solutions for machining various parts to satisfy your machining requirement. Sonderwerkzeuglösungen für die Bearbeitung unterschiedlicher Werkstücke.

A

General Turning · Allgemeine Drehbearbeitung

Parting & Grooving · Ab- & Einstechen



-MG Chip breaker Spanbrecher

■ Reduction of tool cost by using one special design insert in various.

- One insert fits to several tool holders
- One insert suitable for several applications
- Reduction of tool cost and warehouse charges

■ Reduzierung der Werkzeugkosten mit dem Einsatz nur einer Stechgeometrie für viele Anwendungsbereiche.

- Stechplatte paßt auf versch. Haltersysteme
- Stechpl. geeignet für versch. Bearbeitungen
- Reduzierung der Werkzeug- und Lagerkosten

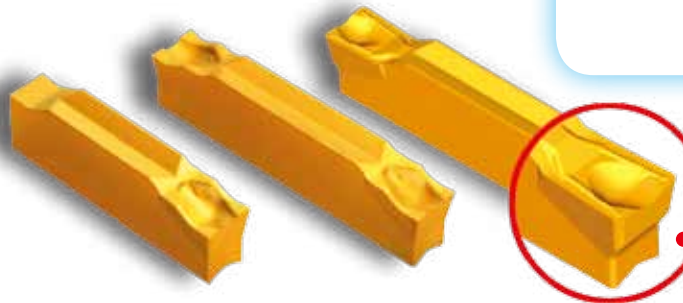

■ Unique structure design of parting inserts

- A special flank structure is designed to reduce cutting force by 20% and diminish shake, which improve the surface quality
- A special edge design requires less rigidity of machine, it can be used on machine with small power

■ Einzigartiges Schneidkantendesign für AbStechplatte

- Spezielle Flankenstruktur reduziert die Schnittkräfte um 20%, verhindert Vibrationen und verbessert die Oberflächenqualität
- Eine neu entwickelte Schneidkantenausführung ermöglicht auch den Einsatz auf leistungsschwachen Maschinen.

■ Universal **-MG** chip breaker series

Suitable for parting, grooving, profiling and turning etc; good chip control, surface quality and low cutting force

■ Universelle **-MG** Spanbrecherserie

Einsetzbar zum Stechen, Abstechen, für die Profil- und Drehbearbeitung, Gute Spankontrolle.

Gute Oberflächengüten und niedrige Schnittkräfte.

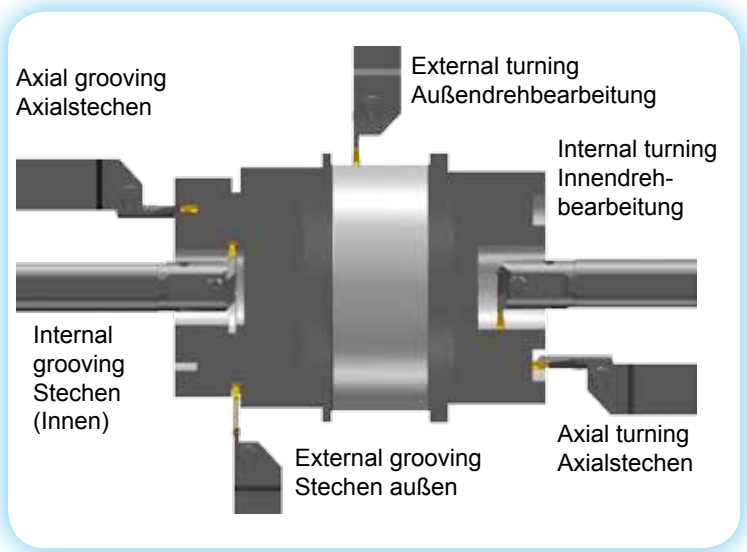

Special design reduce vibration and cutting force 20%

Spezielles Spanbrecherdesign reduziert Vibrationen und Schnittkräfte um 20%



-EG

Precise grooving, profiling & turning inserts

Special chip breaker design, suitable for precision machining of low-carbon steel, stainless steel, adhesive materials and nonferrous metal.

Präzisions Platten für die Stech-, Profil- & Stehdrehbearbeitung

Spezielles Spanbrecherdesign für die Präzisionsbearbeitung von niedriglegiertem Stahl, rostfreiem Stahl, abrasiven Materialien und Ne-Metallen.

The edge width between

1.0-6.5mm according to your requirement.

Stechbreiten von **1.0-6.5 mm** je nach Anforderung.

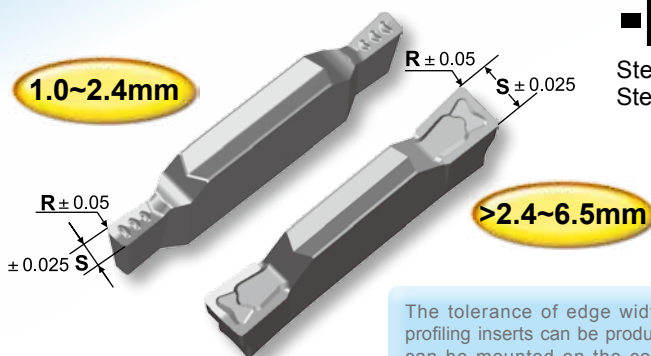

-EG Precision profiling and turning inserts

"Squirrel Series" round Inserts for precision, turning and grooving

-EG Präzisions, Profil- & DrehStechplatte

Stechplatte mit Rundprofil für die Profil, Drehstech- und Stehbearbeitung

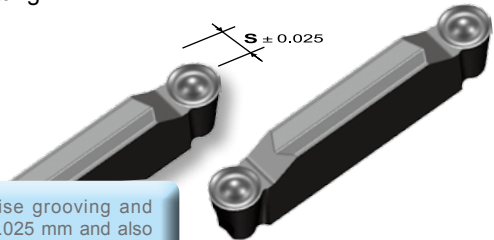

The tolerance of edge width S of precise grooving and profiling inserts can be produced up to ± 0.025 mm and also can be mounted on the corresponding specifications of original toolholder series.

Die Stechbreite S kann mit einer Toleranz bis $\pm 0,025$ mm produziert werden und auf der Standard Halterserie eingesetzt werden.

Profiling turning inserts for AL Profilstechdrehplatten für Alu

The unique chip breaker for aluminum profiling machining. Cutting edge is designed by combining sharpness and intensity, The special chip breaker structure which effectively reduces the frictional coefficient between chips and rake face, enable the inserts suitable for continuous and intermittent profiling Al alloy Machining.

Das einzigartige Spanbrecherdesign für die Profilbearbeitung von Aluminium verbindet eine scharfe Schneidkantenausführung und gleichzeitige Stabilität. Die spezielle Form verhindert die Aufbauschneidenbildung und ist für die Bearbeitung im glatten und leicht unterbrochenem Schnitt einsetzbar.



Turning · Drehen

Parting & Grooving Code Key · Ab- & Einstechen ISO Kennzeichen

Parting, Grooving, Profiling and Turning Code Key

Kennzeichnung für Ab- und Einstechen, Profildrehen und Drehen

Application of insert <i>Anwendung</i>	Code of insert seat size <i>Plattensitzgröße</i>	Number of cutting edge <i>Anzahl Schneiden</i>	Tolerance class <i>Toleranzklasse</i>												
ZP Parting Abstechen	Corresponding code of toolholder and width of cutting edge. Entsprechender Code des Halters und der Schneidenbreite	S Single cutting edge eine Schneide	M Tolerance class Toleranzklasse												
ZT Grooving and Turning Einstechen und Drehen															
ZR Profile machining Formdrehen	<table border="1"> <thead> <tr> <th>Code</th> <th>Height / Höhe</th> </tr> </thead> <tbody> <tr> <td>E</td> <td>2.5</td> </tr> <tr> <td>F</td> <td>3.0</td> </tr> <tr> <td>G</td> <td>4.0</td> </tr> <tr> <td>H</td> <td>5.0</td> </tr> <tr> <td>K</td> <td>6.0</td> </tr> </tbody> </table>	Code	Height / Höhe	E	2.5	F	3.0	G	4.0	H	5.0	K	6.0	D Double cutting edges Zwei Schneiden	E Tolerance class Toleranzklasse
Code	Height / Höhe														
E	2.5														
F	3.0														
G	4.0														
H	5.0														
K	6.0														

ZP G D 04 04 - M G

Width of cutting edge
Schneidplattenbreite



025 = 0.25 mm
03 = 0.30 mm
04 = 0.40 mm
05 = 0.50 mm
06 = 0.60 mm

Corner radius
Eckenradius



02 = 0.20 mm
03 = 0.30 mm
04 = 0.40 mm
08 = 0.80 mm

Chip breaker's code
Spanbrecher

G
 General chip breaker, suitable for all kinds of machined material.
 Allgemeiner Spanbrecher, geeignet für verschiedene Materialien.

Special chip breaker
F *Sonder Spanbrecher*



Parting inserts · Stechplatte

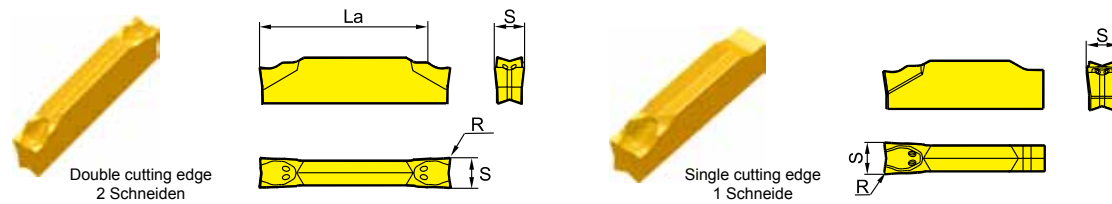

Type · Typ		Dimension (mm) Abmessung			Grade · Sorte						
					P			M		K	N
		S ^{+0.1} ₀	R±0.1	La max	YBG202	YBG302	YBC251	YBG202	YBG302	YBG302	YD101
Double cutting edge 2 Schneiden	ZPED02502-MG	2.5	0.2	17	●	●	●	●	●	●	
	ZPFD0302-MG	3.0	0.2	17	●	●	●	●	●	●	
	ZPGD0402-MG	4.0	0.2	22	●	●	●	●	●	●	
	ZPHD0503-MG	5.0	0.3	22	●	●		●	●	●	
	ZPKD0604-MG	6.0	0.4	22	●	●	●	●	●	●	
Single cutting edge 1 Schneide	ZPES02502-MG	2.5	0.2		○	●	●	○	●	●	
	ZPFS0302-MG	3.0	0.2		○	●	○	○	●	●	
	ZPGS0402-MG	4.0	0.2		○	●	○	○	●	●	
	ZPHS0503-MG	5.0	0.3		○	●	○	○	●	●	
	ZPKS0604-MG	6.0	0.4		●	●		●	●	●	

Insert with single cutting edge only be used to parting blad
Zum Abstechen nur mit Spannblock

Please reduce the feed rate by 30% when the insert is approaching the centre of workpiece.

Für eine längere Standzeit der Wendeschneidplatten, reduzieren Sie bitte den Vorschub um 30%, wenn die Platte sich dem Zentrum nähert.

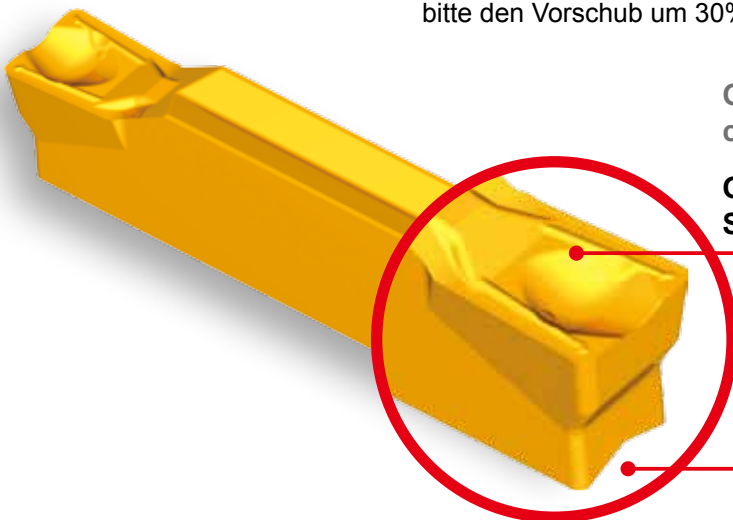

Optimal chip breaker design for good chip control.

Optimaler Spanbrecher für eine gute Spankontrolle.

Cutting force is reduced by 20% less vibration.
Reduziert die Vibrationen und die Schnittkraft um 20%

● ex stock · ab Lager ○ on demand · auf Anfrage

Turning · Drehen

Parting & Grooving · Ab- & Einstechen

ZP*D-MG Series

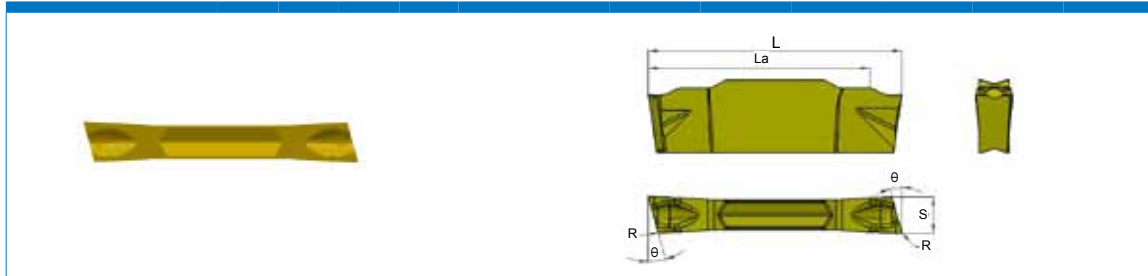

Type · Typ	Dimension (mm) Abmessung					Grade · Sorte						
						P			M		K	N
	L	S	θ	R	La _{max}	YBG202	YBG302		YBG202	YBG302	YBG302	YD101
ZPED02502-MG-6L	20	2.35	6	0.2	17	●	●		●	●	●	○
ZPED02502-MG-6R	20	2.35	6	0.2	17	●	●		●	●	●	○
ZPED02502-MG-15L	20	2.35	15	0.2	17	●	●		●	●	●	○
ZPED02502-MG-15R	20	2.35	15	0.2	17	●	●		●	●	●	○
ZPFD0302-MG-6L	20	2.85	6	0.2	17	●	●		●	●	●	○
ZPFD0302-MG-6R	20	2.85	6	0.2	17	●	●		●	●	●	○
ZPFD0302-MG-15L	20	2.85	15	0.2	17	●	●		●	●	●	○
ZPFD0302-MG-15R	20	2.85	15	0.3	17	●	●		●	●	●	○

ZTBD-MG Series

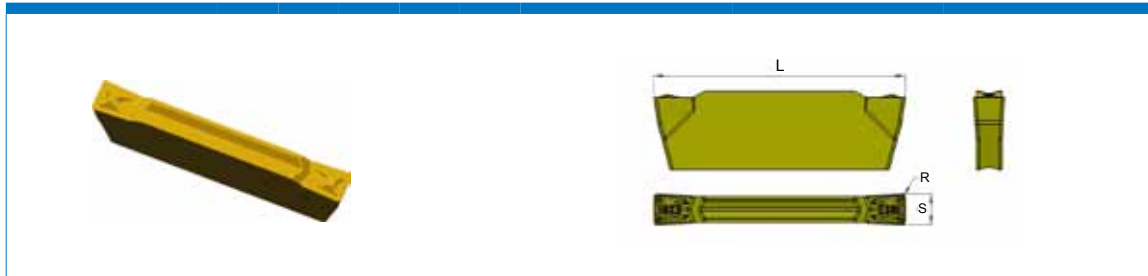

Type · Typ	Dimension (mm) Abmessung					Grade · Sorte		
	L	S ±0.05	R	La _{max}		YBG202	YBG302	
ZTBD02002-MG	16.3	2.0	0.2	13		○	○	

● ex stock · ab Lager ○ on demand · auf Anfrage

Grooving and turning inserts · Einstech- & Drehplatten



Double cutting edge
2 Schneiden

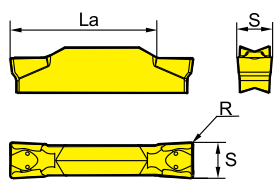

La
S
R



Single cutting edge
1 Schneide

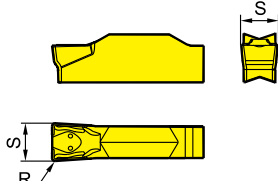

S
R

Type · Typ		Dimension (mm) Abmessung			Grade · Sorte							
					P		M		K		N	
		S ^{+0.1} ₀	R±0.10	La max	YBG202	YBG302		YBG202	YBG302	YBG302	YD101	
Double cutting edge 2 Schneiden	ZTED02503-MG	2.5	0.3	17	●	●		●	●	●		
	ZTFD0303-MG	3.0	0.3	17	●	●		●	●	●		
	ZTGD0404-MG	4.0	0.4	22	●	●		●	●	●		
	ZTHD0504-MG	5.0	0.4	22	●	●		●	●	●		
	ZTKD0608-MG	6.0	0.8	22	●	●		●	●	●		
Single cutting edge 1 Schneide	ZTHS0504-MG	5.0	0.4		○	●			●	●		
	ZTKS0608-MG	6.0	0.8		○	●			●	●		

Precise grooving and turning inserts · Präzisions Stech- & Drehplatten



1.0~2.4mm

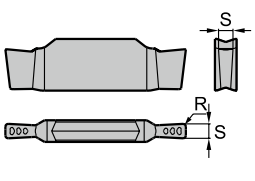

S
R
S



>2.4~6.5mm

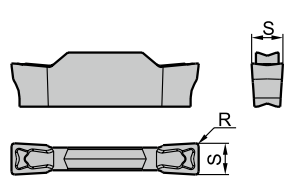

S
R
S

Type · Typ		Dimension (mm) Abmessung			Grade · Sorte							
					P		M		K		N	
		S±0.025	R ⁽²⁾ ±0.05	La max	YBG202	YBG302		YBG202	YBG302	YBG302	YD101	
Double cutting edge 2 Schneiden	ZTC****-EG	1.0~1.6	(2)	2.6		○			○			
		1.6~2.4		3.4								
	ZTE****-EG	2.4~3.0		17		○			○			
	ZTFD****-EG	3.0~3.8		17		○			○			
	ZTGD****-EG	3.8~4.8		22		○			○			
	ZTHD****-EG	4.8~5.8		22		○			○			
ZTKD****-EG	5.8~6.5	22		○				○				

Note: (1) The code indicated with * is to be designated based on the edge width and edge radius. The code will be ZTFD03503-EG if the ordered insert is with an edge width of 3.5mm and an edge radius of 3.0mm.

(2) Edge radius R is based on customers' requirements

Der Bestellnummernschlüssel: (1) z.B. ZTFD03503-EG legt ein Schneidbreite 3.5mm und einen Schneideckenradius 0.3mm fest.

(2) Eckenradius nach Kundenwunsch

● ex stock · ab Lager ○ on demand · auf Anfrage

Turning · Drehen

Parting & Grooving · Ab- & Einstechen

Profiling and turning inserts · Profil- & Stechdrehplatten



Type · Typ		Dimension (mm) Abmessung		Grade · Sorte						
				P		M		K	N	
		S ^{+0.1} ₀	La ^{max}	YBG202	YBG302		YBG202	YBG302	YBG302	YD101
Double cutting edge 2 Schneiden	ZRED025-MG	2.5	20	●	●		●	●	●	
	ZRFD03-MG	3.0	20	●	●		●	●	●	
	ZRGD04-MG	4.0	25	●	●		●	●	●	
	ZRHD05-MG	5.0	25	●	●		●	●	●	
	ZRKD06-MG	6.0	25	●	●		●	●	●	

Precise profiling and turning inserts · Präzisions, Profil- & Stechdrehplatten



Type · Typ		Dimension (mm) Abmessung		Grade · Sorte						
				P		M		K	N	
		S±0.025	La ^{max}	YBG202	YBG302		YBG202	YBG302	YBG302	YD101
Double cutting edge 2 Schneiden	ZRFD03-EG	3.0	20		○			○		
	ZRGD04-EG	4.0	25		○			○		
	ZRHD05-EG	5.0	25		○			○		
	ZRKD06-EG	6.0	25		○			○		

● ex stock · ab Lager ○ on demand · auf Anfrage

■ **Single-cutting edge grooving and turning inserts for machining of heatresistance super alloy**
Einseitige Stech- & Drehplatten für die Bearbeitung von wärmfesten Superlegierung

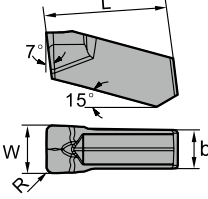
Type · Typ	Dimension (mm) Abmessung				Grade · Sorte			
					S		M	
	W±0.05	R±0.1	b	L	YD101	YBG102	YBG202	YBG202
ZIMF304N-NM	3	0.4	2.4	15.3		●		
ZIMF406N-NM	4	0.6	3.2	15.3		●		
ZIMF506N-NM	5	0.6	4	15.3		●		
ZIMF608N-NM	6	0.8	4	15.3		●		

Turning · Drehen

Parting & Grooving · Ab- & Einstechen

A

General Turning · Allgemeine Drehbearbeitung

- Single-cutting edge grooving and turning inserts for machining of heatresistance super alloy
Einseitige Stech- & Drehplatten für die Bearbeitung von wärmefesten Superlegierungen

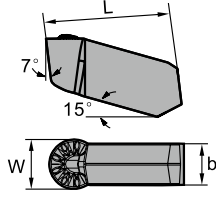
							
Type · Typ	Dimension (mm) Abmessung			Grade · Sorte			
	W±0.025	b	L	S			M
				YD101	YBG102	YBG202	YBG202
ZIGQ3N-NM	3	2.4	15.3		●		
ZIGQ4N-NM	4	3.2	15.3		●		
ZIGQ5N-NM	5	4	15.3		●		
ZIGQ6N-NM	6	5	15.3		●		

- Profiling Inserts for Al · Profilstechdrehplatten zur Aluminiumbearbeitung

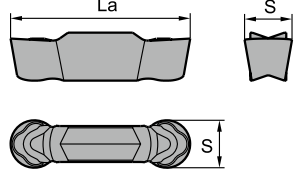
			
Type · Typ	Dimension (mm) Abmessung		Grade · Sorte
	S±0.025	La max	YD101
ZRKD06-LH	6.0	25	●
ZRLD08-LH	8.0	30	●

● ex stock · ab Lager ○ on demand · auf Anfrage

Parting & Grooving · Ab- & Einstechen

154.3 Series

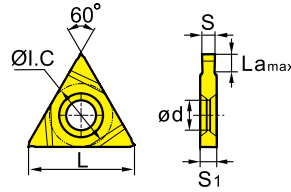

Type · Typ	Dimension (mm) Abmessung						Grade · Sorte						
							P			M			K
	L	I.C	S	S ₁	d	L _{max}	YBC251	YC10	YC40	YBC251	YC10	YC40	YD201
154.3-16110	16.5	9.525	1.1	2.5	4.5	1.2		●	●		●	●	
154.3-16130	16.5	9.525	1.3	2.5	4.5	1.5		●	●		●	●	
154.3-16160	16.5	9.525	1.6	2.5	4.5	1.8		●	●		●	●	●
154.3-16185	16.5	9.525	1.85	2.5	4.5	2.8		●	●		●	●	●
154.3-16215	16.5	9.525	2.15	2.8	4.5	2.8		●	●		●	●	
154.3-16265	16.5	9.525	2.65	3.3	4.5	2.8		●	●				
154.3-16315	16.5	9.525	3.15	3.8	4.5	2.8		●	●		●	●	●
154.3-16415	16.5	9.525	4.15	4.8	4.5	3.0		●	●		●	●	●

ZQMX Series

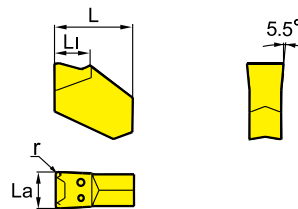

Type · Typ	Dimension (mm) Abmessung				Grade · Sorte						
					P			M			K
	L1	La	r	L	YBC251	YC10	YC40	YBC251	YC10	YC40	YD201
ZQMX3N11-1E	4.4	3.125	0.3	11	●			●			
ZQMX4N11-1E	4.95	4.125	0.3	11	●			●			
ZQMX5N11-1E	5	5.125	0.3	11	●			●			
ZQMX6N11-1E	5.28	6.4	0.3	11	●			●			
ZQMX7N11-1E	4.53	7.05	0.3	14							

● ex stock · ab Lager ○ on demand · auf Anfrage

Turning · Drehen

Parting & Grooving · Ab- & Einstechen

A

General Turning · Allgemeine Drehbearbeitung

Parting & Grooving · Ab- & Einstechen

ZSMF·ZSMX Series

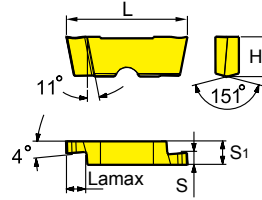

Type · Typ	Dimension (mm) Abmessung					Grade · Sorte		
						P	M	K
	L	S1	H	Lamax	S	YC10	YC10	YD201
ZSMF3110L	16	3.1	5.26	2.1	1.1	●	●	
ZSMF3130L	16	3.1	5.26	2.3	1.3	●	●	
ZSMF3160L	16	3.1	5.26	2.6	1.6	●	●	○
ZSMF3185L	16	3.1	5.26	2.9	1.85	●	●	○
ZSMF3215L	16	3.1	5.26	3.2	2.15	●	●	
ZSMF3265L	16	3.1	5.26	3.7	2.65	●	●	○
ZSMF5500L	22	5.1	6.26	6	5	●	●	
ZSMX8515L	27	8.1	7.26	6.2	5.15			

ZSMF·ZSMX Series

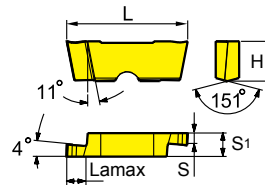

Type · Typ	Dimension (mm) Abmessung					Grade · Sorte		
						P	M	K
	L	S1	H	Lamax	S	YC10	YC10	YD201
ZSMF3110R	16	3.1	5.26	2.1	1.1	●	●	
ZSMF3130R	16	3.1	5.26	2.3	1.3	●	●	
ZSMF3160R	16	3.1	5.26	2.6	1.6	●	●	○
ZSMF3185R	16	3.1	5.26	2.9	1.85	●	●	
ZSMF3215R	16	3.1	5.26	3.2	2.15	●	●	○
ZSMF3265R	16	3.1	5.26	3.7	2.65	●	●	○
ZSMF5500R	22	5.1	6.26	6	5	●	●	
ZSMX8515R	27	8.1	7.26	6.2	5.15			

● ex stock · ab Lager ○ on demand · auf Anfrage

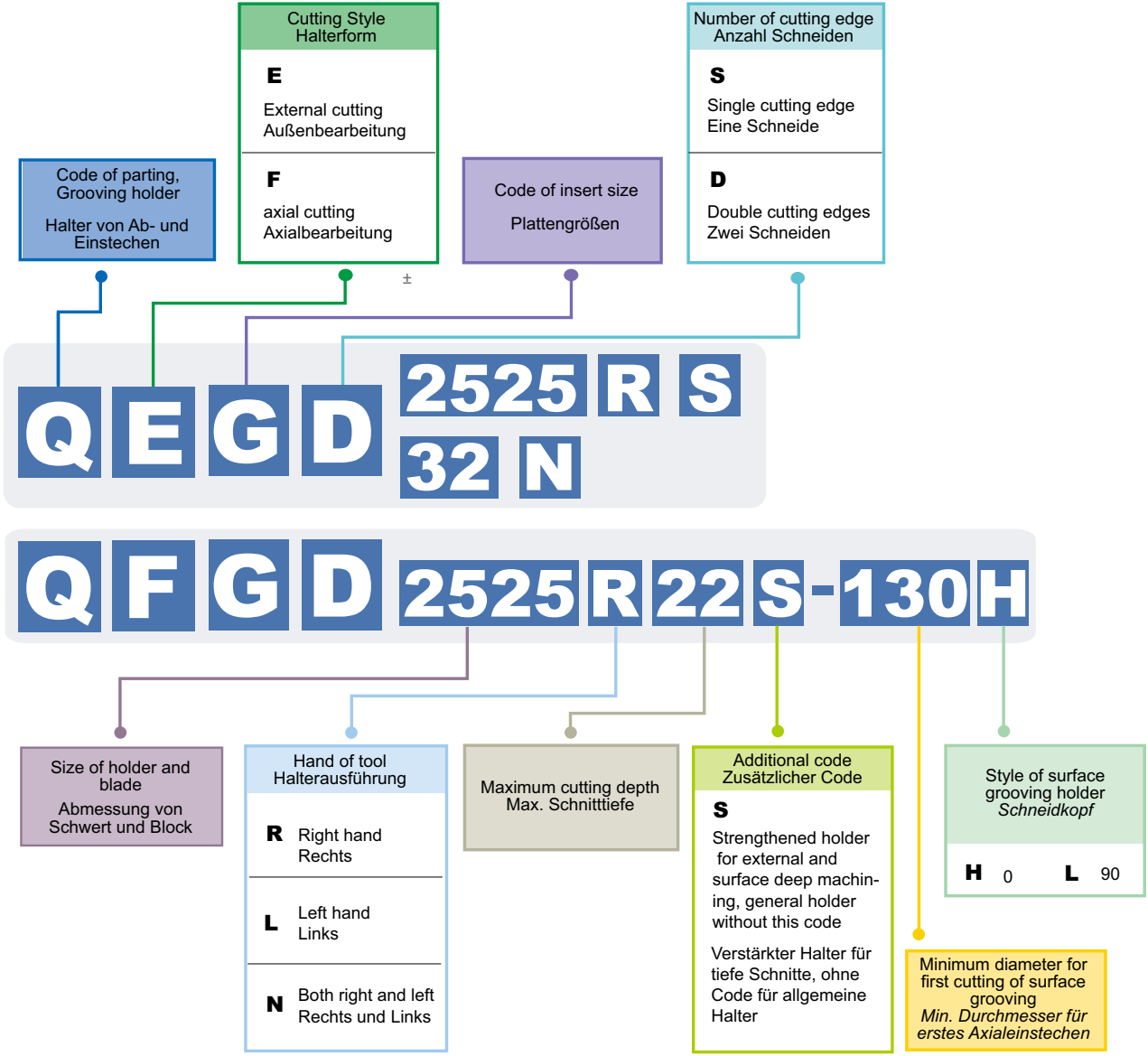

Turning · Drehen

Parting & Grooving Tools Key Code- Ab- & Einstechwerkzeuge ISO Kennzeichen

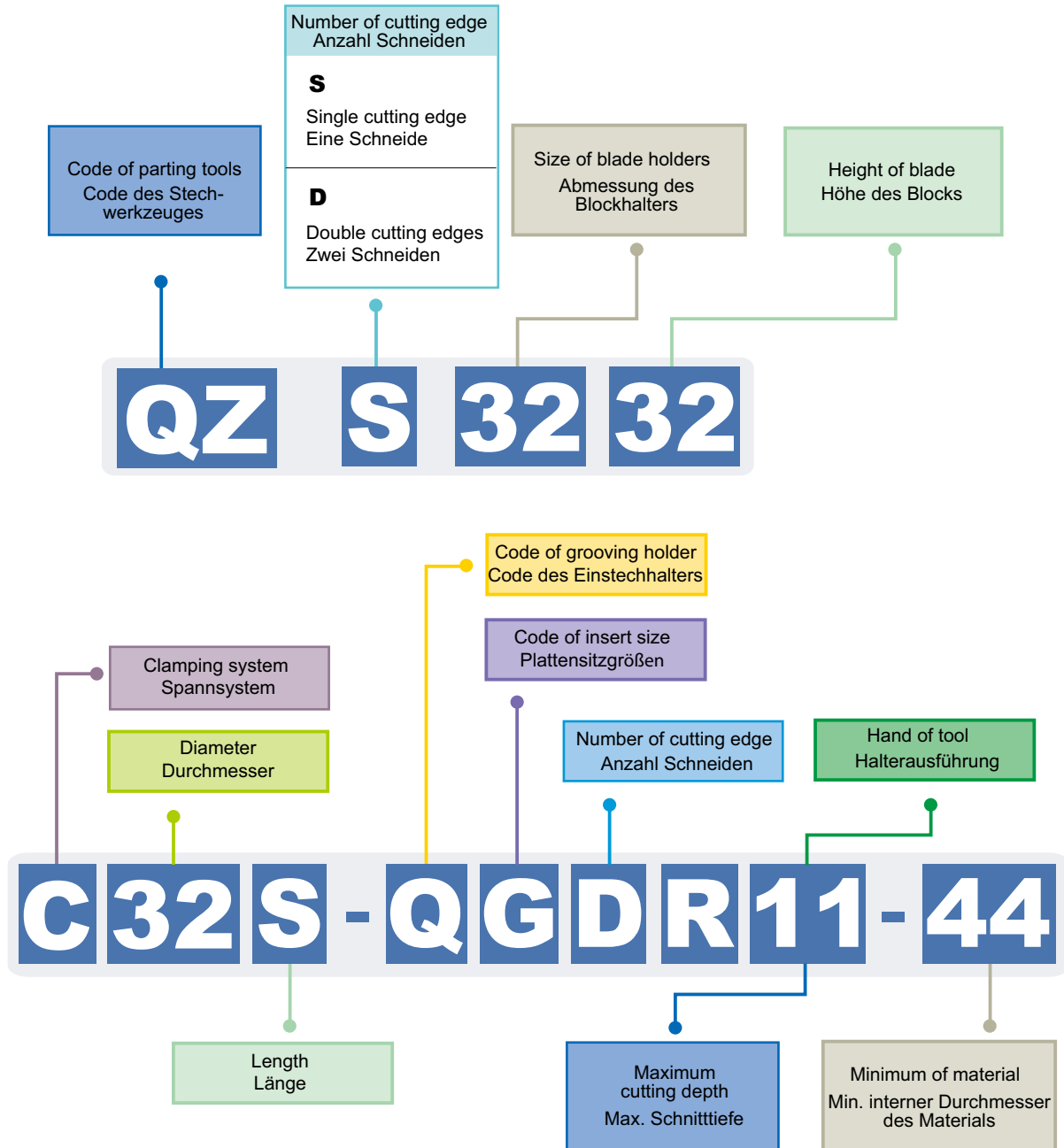

External parting, grooving and turning tools · Einstech- & Drehwerkzeuge (Außen)

Type · Typ		Stock		Dimension (mm) Abmessung				Inserts Stechplatte	Screw Schraube	Wrench Schlüssel	
		R	L	H×B	L	S	W				$\alpha_{r \max}$
QEBD	2020R/L07	●	●	20×20	150	20.17	2	7	ZTBD02002	M5×16	WH40L
	1616R/L04	●	●	16×16	150	16.17	2	4	ZTBD02002		

External parting, grooving and turning tools · Einstech- & Drehwerkzeuge (Außen)

Type · Typ		Stock		Dimension (mm) Abmessung				Inserts Stechplatte	Screw Schraube	Wrench Schlüssel	
		R	L	d	L	S	W				$\alpha_{r \max}$
	C16M-QBDR/L04-20	●	●	16	150	12	2	4	ZTBD02002-MG	M5×10	WH40L



● ex stock · ab Lager ○ on demand · auf Anfrage

Turning · Drehen

Parting & Grooving · Ab- & Einstechen

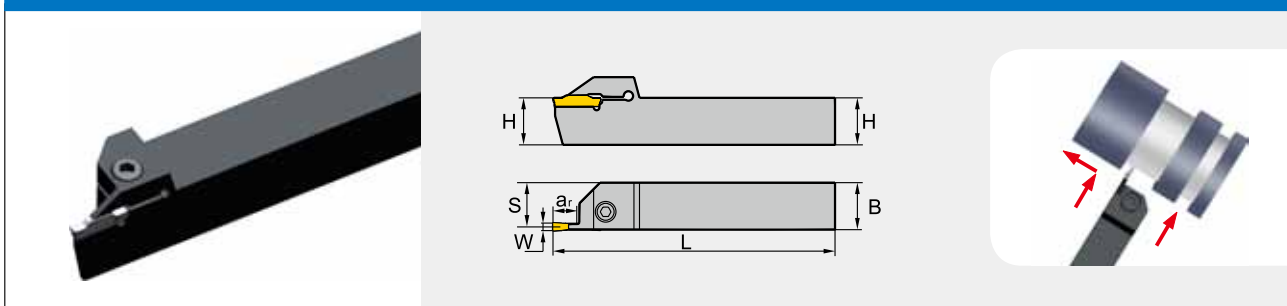
External parting, grooving and turning tools · Einstech- & Drehwerkzeuge (Außen)





Type · Typ		Stock		Dimension (mm) Abmessung					Inserts Stechplatten	Screw Schraube	Wrench Schlüssel		
		R	L	H×B	L	S	W	ar max					
QEED	1616R/L10	●	●	16×16	125	15	2.5	10	Z*ED025**	GB70-85-M5×20	WH40L		
	1616R/L17	●	●	16×16	125	15	2.5	17	Z*ED025**				
	2020R/L10	●	●	20×20	15	10	2.5	10	Z*ED025**				
	2020R/L17	●	●	20×20	25	19	2.5	17	Z*ED025**	GB70-85-M6×20	WH50L		
	2525R/L10	●	●	25×25	150	19	2.5	10	Z*ED025**				
	2525R/L17	●	●	25×25	150	19	2.5	17	Z*ED025**				
QEFD	1616R/L10	●	●	16×16	125	14.8	3	10	Z*FD03**	GB70-85-M5×20	WH40L		
	1616R/L17	●	●	16×16	125	14.8	3	17	Z*FD03**				
	2020R/L10	●	●	20×20	125	18.8	3	10	Z*FD03**				
	2020R/L17	●	●	20×20	125	18.8	3	17	Z*FD03**	GB70-85-M6×20	WH50L		
	2525R/L10	●	●	25×25	150	3.8	3	10	Z*FD03**				
	2525R/L17	●	●	25×25	150	23.8	3	17	Z*FD03**				
QEGD	2020R/L13	●	●	20×20	140	18.5	4	13	Z*FD04**	GB70-85-M6×20	WH50L		
	2020R/L22	●	●	20×20	140	18.5	4	22	Z*GD04**				
	2525R/L13	●	●	25×25	150	23.5	4	13	Z*GD04**				
	2525R/L22	●	●	25×25	150	23.5	4	22	Z*GD04**				
	3232R/L13	●	●	32×32	170	30.5	4	13	Z*GD04**				
	3232R/L22	●	●	32×32	170	30.	4	22	Z*GD04**				
QEHD	2525R/L13	●	●	25×25	150	23	5	13	Z*HD05**	GB70-85-M6×20	WH50L		
	2525R/L22	●	●	25×25	15	23	5	22	Z*HD05**				
QEHS	2525N30	○		25×25	150	12.5	5	30	Z*HS05**				
QEHD	3232R/L13	●	●	32×32	170	30	5	13	Z*HD05**				
	3232R/L22	●	●	32×32	170	30	5	22	Z*HD05**				
QEHS	3232N30	○		32×32	170	16	5	30	Z*HS05**				
QEKD	2525R/L13	●	●	25×25	150	22.6	6	13	Z*KD06**			GB70-85-M6×20	WH50L
	2525R/L22	●	●	25×25	150	22.6	6	22	Z*KD06**				
QEKS	2525N30	○		25×25	15	12.5	6	30	Z*KS06**				
QEKD	3232R/L13	●	●	32×32	170	29.6	6	13	Z*KD06**				
	3232R/L22	●	●	32×32	170	29.6	6	22	Z*KD06**				
QEKS	3232N30	○		32×32	170	16	6	30	Z*KS06**				

● ex stock · ab Lager ○ on demand · auf Anfrage

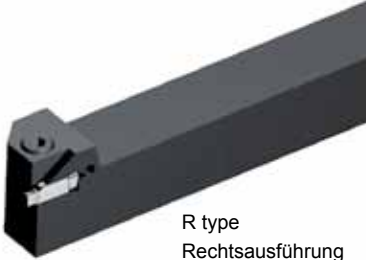
Precise grooving and turning tools · Präzisions Einstech- & Drehwerkzeuge

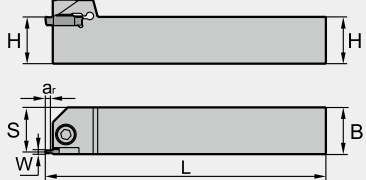





R type
Rechtsausführung

Type · Typ		Stock		Dimension (mm) Abmessung					Inserts Stechplatten	Screw Schraube	Wrench Schlüssel
		R	L	H×B	L	S	W	a _r max			
QECD	1616R/L025	○	○	16×16	125	14.75		2.5	ZT**D***-EG	GB70-85-M5×20	WH40L
	2020R/L025	○	○	20×20	125	18.75					
	2525R/L025	○	○	25×25	150	23.75					

External recess and profiling turning tools · Hinterdrehstech- & Profildrehwerkzeuge (Außen)



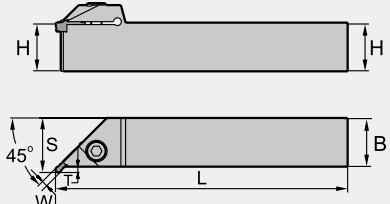

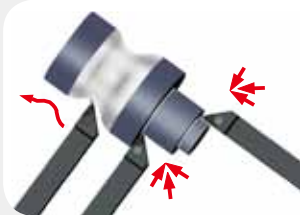

R type
Rechtsausführung

Type · Typ		Stock		Dimension (mm) Abmessung					Inserts Stechplatten	Screw Schraube	Wrench Schlüssel
		R	L	H×B	L	S	W	a _r max			
QXFD	2020R/L03-45	○	○	20×20	125	23	3.0	3.0	ZR(T)FD03-EG ZR(T)FD03-MG	GB70-85-M6×20	WH50L
	2525R/L03-45	○	○	25×25	150	28					
	3232R/L03-45	○	○	32×32	170	35					
QXGD	2020R/L03-45	○	○	20×20	125	23	4.0	3.0	ZR(T)GD04-EG ZR(T)GD04-MG	GB70-85-M6×20	WH50L
	2525R/L03-45	○	○	25×25	150	28					
	3232R/L03-45	○	○	32×32	170	35					
QXHD	2020R/L04-45	○	○	20×20	125	24	5.0	4.0	ZR(T)HD05-EG ZR(T)HD05-MG	GB70-85-M6×20	WH50L
	2525R/L04-45	○	○	25×25	150	29					
	3232R/L04-45	○	○	32×32	170	36					
QXKD	2020R/L04-45			20×20	125	24	6.0	4.0	ZR(T)KD06-EG ZR(T)KD06-MG	GB70-85-M6×20	WH50L
	2525R/L04-45	○	○	25×25	150	29					
	3232R/L04-45	○	○	32×32	170	36					

● ex stock · ab Lager ○ on demand · auf Anfrage

Turning · Drehen

Parting & Grooving · Ab- & Einstechen

External grooving tools for difficult machining

Stechdrehwerkzeug für die schwierige Bearbeitung (Außen)

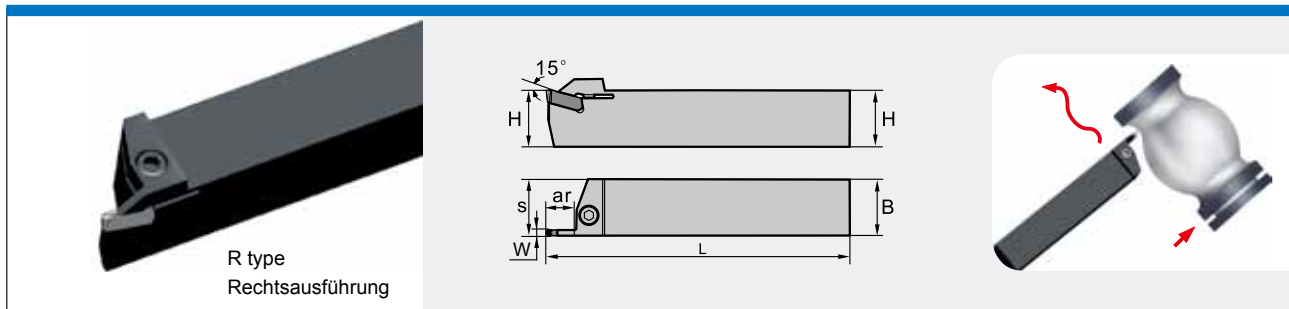

Type · Typ		Stock		Dimension (mm) Abmessung					Inserts Stechplatten	Screw Schraube	Wrench Schlüssel
		R	L	H×B	L	S	W	ar max			
QEFS	2525R/L12-3N	○	○	25×25	150	25.3	3	12	ZIGQ3N-NM ZIMF304N-NM	GB70-85-M6×20	WH50L
	3232R/L22-3N	○	○	32×32	170	32.3	3	22			
QEGS	2525R/L12-4N	○	○	25×25	150	25.3	4	12	ZIGQ4N-NM ZIMF406N-NM		
	3232R/L22-4N	○	○	32×32	170	32.3	4	22			
QEHS	2525R/L12-5N	○	○	25×25	150	25.4	5	12	ZIGQ5N-NM ZIMF506N-NM		
	3232R/L22-5N	○	○	32×32	170	32.4	5	22			
QEKS	2525R/L12-6N	○	○	25×25	150	25.4	6	12	ZIGQ6N-NM ZIMF608N-NM		
	3232R/L22-6N	○	○	32×32	170	32.4	6	22			

● ex stock · ab Lager ○ on demand · auf Anfrage

Blade for external parting · Abstechschwert zur Außenbearbeitung

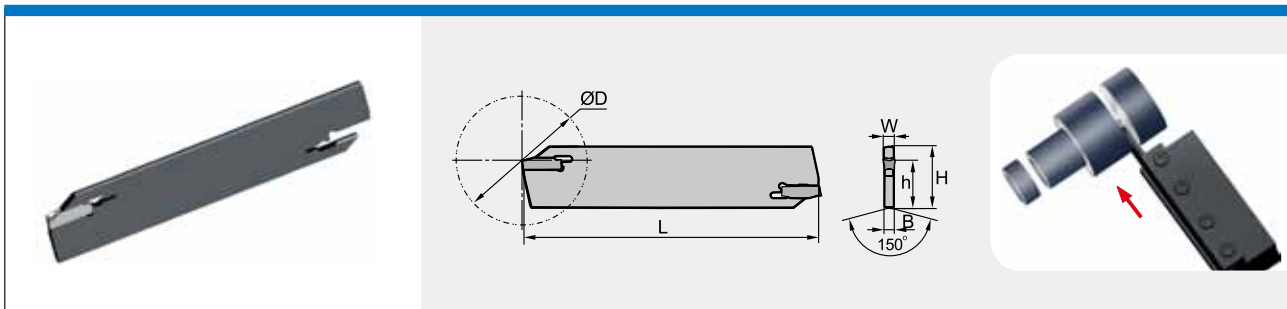

Type · Typ	Stock	Dimension (mm) Abmessung						Inserts Stechplatten	Wrench Schlüssel
		L	H	h	B	W	ØD max		
QEES26N	●	110	26	19	2	2.5	60	ZPES02502-MG	W50RL
QEFS26N	●	110	26	19	2.4	3	60	ZPFS0302-MG	
QEGS26N	●	110	26	19	3.2	4	70	ZPGS0402-MG	
QEHS26N	○	110	26	19	4	5	70	ZPHS0503-MG	
QEKs26N	○	110	26	19	5	6	70	ZPKS0604-MG	
QEES32N	●	150	32	24.6	2	2.5	100	ZPES02502-MG	
QEFS32N	●	150	32	24.6	2.4	3	100	ZPFS0302-MG	
QEGS32N	●	150	32	24.6	3.2	4	120	ZPGS0402-MG	
QEHS32N	●	150	32	24.6	4	5	120	ZPHS0503-MG	
QEKs32N	●	150	32	24.6	5	6	120	ZPKS0604-MG	

Holder for external parting · Spannblock zur Außenbearbeitung

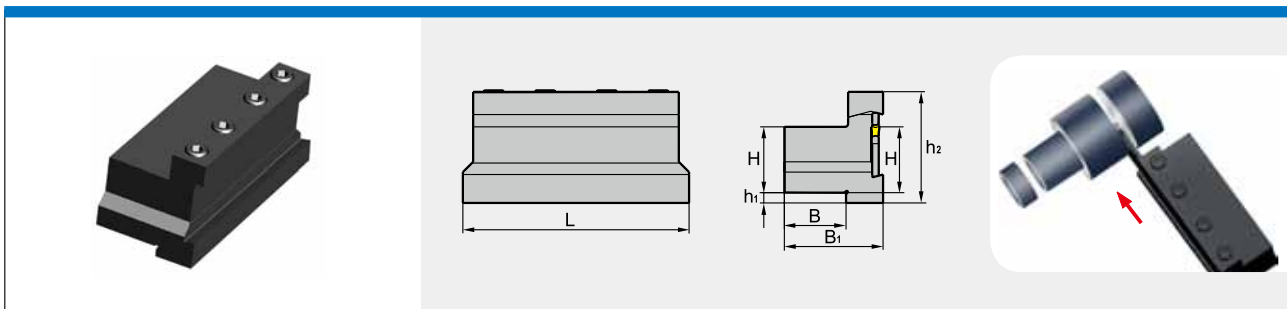

Type · Typ	Stock	Dimension (mm) Abmessung						Clamp Klemme	Screw Schraube	Wrench Schlüssel
		L	H	h ₁	h ₂	B	B ₁			
QZS2026	●	86	20	10	46.6	19	38	QZC26	GB70-85-M6×20	WH50L
QZS2526	●	86	25	5	46.6	23	42	QZC26		
QZS3226	●	86	32	3	51.6	30	48	QZC26		
QZS2032	○	110	20	13	50	19	38	QZC32		
QZS2532	●	110	25	8	50	23	42	QZC32		
QZS3232	●	110	32	5	54	30	48	QZC32		

● ex stock · ab Lager ○ on demand · auf Anfrage

Turning · Drehen

Parting & Grooving · Ab- & Einstechen

■ Axial grooving and turning tools · Axialstech- & Drehwerkzeug

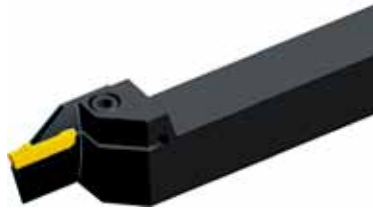

L type
Linksausführung

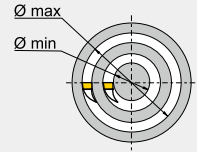
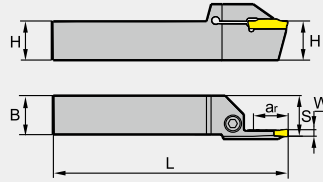

ØD= Range of entering
ØD= Bereich





Type · Typ		Stock		Dimension (mm) Abmessung						Inserts Stechplatten	Screw Schraube	Wrench Schlüssel
		R	L	H×B	L	S	W	ar max	ØD (min-max)			
QFFD	2020R/L7-48H	○	○	20×20	150	21	3	7	48-66	ZTFD0303-MG	GB70-85-M6×20	WH50L
	2020R/L10-48H	○	○	20×20	150	21	3	10	48-66			
	2525R/L10-48H	●	●	25×25	150	26	3	10	48-66			
	2525R/L17-48H	●	●	25×25	150	26	3	17	48-66			
	2020R/L7-60H	○	○	20×20	150	21	3	7	60-80			
	2020R/L10-60H	○	○	20×20	150	21	3	10	60-80			
	2525R/L10-60H	●	●	25×25	150	26	3	10	60-80			
	2525R/L17-60H	●	●	25×25	150	26	3	17	60-80			
	2020R/L7-74H	○	○	20×20	150	21	3	7	74-110			
	2020R/L10-74H	○	○	20×20	150	21	3	10	74-110			
	2525R/L10-74H	●	●	25×25	150	26	3	10	74-110			
	2525R/L17-74H	●	●	25×25	150	26	3	17	74-110			
	2020R/L7-100H	○	○	20×20	150	21	3	7	100-150			
	2020R/L10-100H	○	○	20×20	150	21	3	10	100-150			
2525R/L10-100H	●	●	25×25	150	26	3	10	100-150				
2525R/L17-100H	●	●	25×25	150	26	3	17	100-150				
QFGD	2020R/L10-52H	○	○	20×20	150	21	4	10	52-72	ZTGD0404-MG	GB70-85-M6×20	WH50L
	2525R/L13-52H	●	●	25×25	150	26	4	13	52-72			
	2020R/L15-52H	○	○	20×20	150	21	4	15	52-72			
	2525R/L22-52H	●	●	25×25	150	26	4	22	52-72			
	2020R/L10-64H	○	○	20×20	150	21	4	10	64-100			
	2525R/L13-64H	●	●	25×25	150	26	4	13	64-100			
	2020R/L15-64H	○	○	20×20	150	21	4	15	64-100			
	2525R/L22-64H	●	●	25×25	150	26	4	22	64-100			
	2020R/L10-90H	○	○	20×20	150	21	4	10	90-140			
	2525R/L13-90H	●	●	25×25	150	26	4	13	90-140			
	2020R/L15-90H	○	○	20×20	150	21	4	15	90-140			
	2525R/L22-90H	●	●	25×25	150	26	4	22	90-140			
	2020R/L10-130H	○	○	20×20	150	21	4	10	130-230			
	2525R/L13-130H	●	●	25×25	150	26	4	13	130-230			
2020R/L15-130H	○	○	20×20	150	21	4	15	130-230				
2525R/L22-130H	●	●	25×25	150	26	4	22	130-230				

● ex stock · ab Lager ○ on demand · auf Anfrage

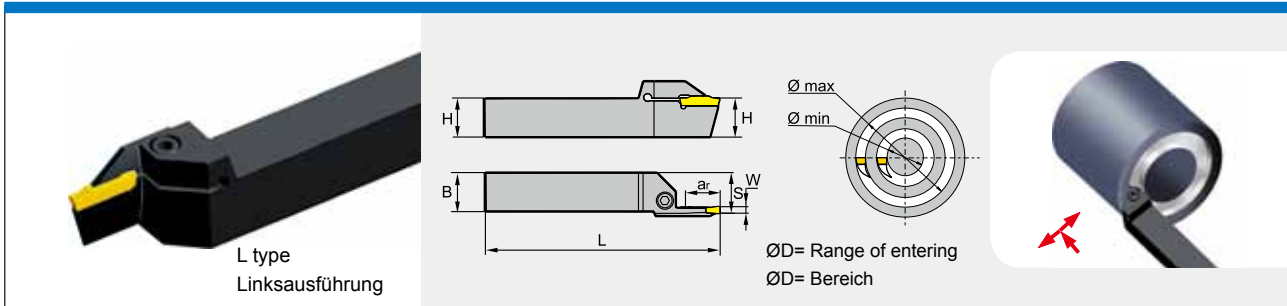
■ Axial grooving and turning tools · Axialstech- & Drehwerkzeug



Type · Typ		Stock		Dimension (mm) Abmessung						Inserts Stechplatten	Screw Schraube	Wrench Schlüssel
		R	L	H×B	L	S	W	ar _{max}	ØD (min-max)			
QFHD	2525R/L13-58H	●	●	25×25	150	26	5	13	58-96	ZTHD0504-MG	GB70-85-M6×20	WH50L
	2525R/L22-58H	●	●	25×25	150	26	5	22	58-96			
	2525R/L13-86H	●	●	25×25	150	26	5	13	86-140			
	2525R/L22-86H	●	●	25×25	150	26	5	22	86-140			
	2525R/L13-130H	●	●	25×25	150	26	5	13	130-200			
	2525R/L22-130H	●	●	25×25	150	26	5	22	130-200			
	2525R/L13-185H	●	●	25×25	150	26	5	13	185-400			
2525R/L22-185H	●	●	25×25	150	26	5	22	185-400				
QFHS	2525R/L30-185H	●	●	25×25	150	26	5	30	185-400	ZTHS0504-MG		
QFKD	2525R/L13-60H	●	●	25×25	150	26	6	13	60-100	ZTKD0608-MG	GB70-85-M6×20	WH50L
	2525R/L22-60H	●	●	25×25	150	26	6	22	60-100			
	2525R/L13-88H	○	●	25×25	150	26	6	13	88-180			
	2525R/L22-88H	●	●	25×25	150	26	6	22	88-180			
	2525R/L13-160H	●	●	25×25	150	26	6	13	160-400			
2525R/L22-160H	●	●	25×25	150	26	6	22	160-400				
QFKS	2525R/L30-160H	●	●	25×25	150	26	6	30	160-400	ZTKS0608-MG		



● ex stock · ab Lager ○ on demand · auf Anfrage

Turning · Drehen

Parting & Grooving · Ab- & Einstechen

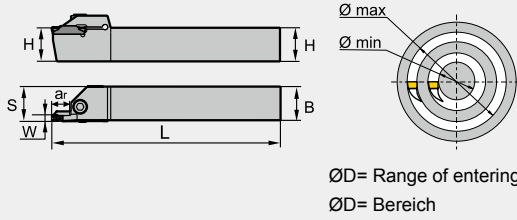
■ Axial grooving and turning tools · Axialstech- & Drehwerkzeug



Type · Typ		Stock		Dimension (mm) Abmessung						Inserts Stechplatten	Screw Schraube	Wrench Schlüssel
		R	L	H×B	L	S	W	ar max	ØD (min-max)			
QFFD	2020RR7-48H	○	○	20×20	150	21	3	7	48-66	ZTFD0303-MG	GB70-85-M6×20	WH50L
	2020RR10-48H	○	○	20×20	150	21	3	10	48-66			
	2525RR10-48H	○	○	25×25	150	26	3	10	48-66			
	2525RR17-48H	○	○	25×25	150	26	3	17	48-66			
	2020RR7-60H	○	○	20×20	150	21	3	7	60-80			
	2020RR10-60H	○	○	20×20	150	21	3	10	60-80			
	2525RR10-60H	○	○	25×25	150	26	3	10	60-80			
	2525RR17-60H	○	○	25×25	150	26	3	17	60-80			
	2020RR7-74H	○	○	20×20	150	21	3	7	74-110			
	2020RR10-74H	○	○	20×20	150	21	3	10	74-110			
	2525RR10-74H	○	○	25×25	150	26	3	10	74-110			
	2525RR17-74H	○	○	25×25	150	26	3	17	74-110			
	2020RR7-100H	○	○	20×20	150	21	3	7	100-150			
	2020RR10-100H	○	○	20×20	150	21	3	10	100-150			
2525RR10-100H	○	○	25×25	150	26	3	10	100-150				
2525RR17-100H	○	○	25×25	150	26	3	17	100-150				
QFGD	2020RR10-52H	○	○	20×20	150	21	4	10	52-72	ZTGD0404-MG	GB70-85-M6×20	WH50L
	2020RR15-52H	○	○	20×20	150	26	4	15	52-72			
	2525RR13-52H	○	○	25×25	150	21	4	13	52-72			
	2525RR22-52H	○	○	25×25	150	26	4	22	52-72			
	2020RR10-64H	○	○	20×20	150	21	4	10	64-100			
	2020RR15-64H	○	○	20×20	150	26	4	15	64-100			
	2525RR13-64H	○	○	25×25	150	21	4	13	64-100			
	2525RR22-64H	○	○	25×25	150	26	4	22	64-100			
	2020RR10-90H	○	○	20×20	150	21	4	10	90-140			
	2020RR15-90H	○	○	20×20	150	26	4	15	90-140			
	2525RR13-90H	○	○	25×25	150	21	4	13	90-140			
	2525RR22-90H	○	○	25×25	150	26	4	22	90-140			
	2020RR10-130H	○	○	20×20	150	21	4	10	130-230			
	2020RR15-130H	○	○	20×20	150	26	4	15	130-230			
2525RR13-130H	○	○	25×25	150	21	4	13	130-230				
2525RR22-130H	○	○	25×25	150	26	4	22	130-230				

● ex stock · ab Lager ○ on demand · auf Anfrage

■ Axial grooving and turning tools · Axialstech- & Drehwerkzeug

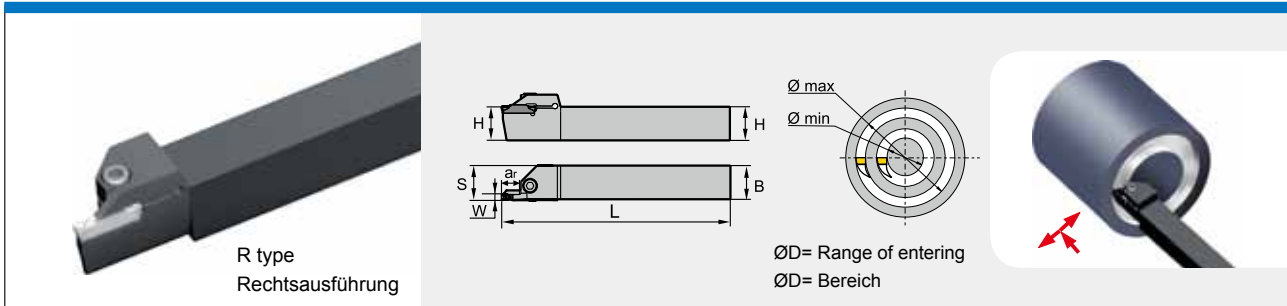

R type
Rechtsausführung

ØD= Range of entering
ØD= Bereich

Type · Typ		Stock		Dimension (mm) Abmessung						Inserts Stechplatten	Screw Schraube	Wrench Schlüssel
		R	L	H×B	L	S	W	ar max	ØD (min-max)			
QFHD	2525RR13-58H	○	○	25×25	150	26	5	13	58-96	ZTHD0504-MG	GB70-85-M6×20	WH50L
	2525RR22-58H	○	○	25×25	150	26	5	22	58-96			
	2525RR13-86H	○	○	25×25	150	26	5	13	86-140			
	2525RR22-86H	○	○	25×25	150	26	5	22	86-140			
	2525RR13-130H	○	○	25×25	150	26	5	13	130-200			
	2525RR22-130H	○	○	25×25	150	26	5	22	130-200			
	2525RR13-185H	○	○	25×25	150	26	5	13	185-400			
	2525RR22-185H	○	○	25×25	150	26	5	22	185-400			
QFHS	2525RR30-185H	○	○	25×25	150	26	5	30	185-400	ZTHS0504-MG		
QFKD	2525RR13-60H	○	○	25×25	150	26	6	13	60-100	ZTKD0608-MG	GB70-85-M6×20	WH50L
	2525RR22-60H	○	○	25×25	150	26	6	22	60-100			
	2525RR13-88H	○	○	25×25	150	26	6	13	88-180			
	2525RR22-88H	○	○	25×25	150	26	6	22	88-180			
	2525RR13-160H	○	○	25×25	150	26	6	13	160-400			
	2525RR22-160H	○	○	25×25	150	26	6	22	160-400			
QFKS	2525RR30-160H	○	○	25×25	150	26	6	30	160-400	ZTKS0608-MG		

● ex stock · ab Lager ○ on demand · auf Anfrage

Turning · Drehen

Parting & Grooving · Ab- & Einstechen

■ Axial grooving and turning tools · Axialstech- & Drehwerkzeug



L type
Linksausführung

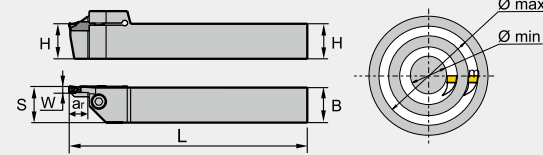

ØD= Range of entering
ØD= Bereich



Type · Typ		Stock		Dimension (mm) Abmessung						Inserts Stechplatten	Screw Schraube	Wrench Schlüssel
		R	L	H×B	L	S	W	ar max	ØD (min-max)			
QFFD	2020LL7-48H	○	○	20×20	150	21	3	7	48-66	ZTFD0303-MG	GB70-85-M6×20	WH50L
	2020LL10-48H	○	○	20×20	150	21	3	10	48-66			
	2525LL10-48H	○	○	25×25	150	26	3	10	48-66			
	2525LL17-48H	○	○	25×25	150	26	3	17	48-66			
	2020LL7-60H	○	○	20×20	150	21	3	7	60-80			
	2020LL10-60H	○	○	20×20	150	21	3	10	60-80			
	2525LL10-60H	○	○	25×25	150	26	3	10	60-80			
	2525LL17-60H	○	○	25×25	150	26	3	17	60-80			
	2020LL7-74H	○	○	20×20	150	21	3	7	74-110			
	2020LL10-74H	○	○	20×20	150	21	3	10	74-110			
	2525LL10-74H	○	○	25×25	150	26	3	10	74-110			
	2525LL17-74H	○	○	25×25	150	26	3	17	74-110			
	2020LL7-100H	○	○	20×20	150	21	3	7	100-150			
	2020LL10-100H	○	○	20×20	150	21	3	10	100-150			
	2525LL10-100H	○	○	25×25	150	26	3	10	100-150			
2525LL17-100H	○	○	25×25	150	26	3	17	100-150				
QFGD	2020LL10-52H	○	○	20×20	150	21	4	10	52-72	ZTGD0404-MG	GB70-85-M6×20	WH50L
	2020LL15-52H	○	○	20×20	150	26	4	15	52-72			
	2525LL13-52H	○	○	25×25	150	21	4	13	52-72			
	2525LL22-52H	○	○	25×25	150	26	4	22	52-72			
	2020LL10-64H	○	○	20×20	150	21	4	10	64-100			
	2020LL15-64H	○	○	20×20	150	26	4	15	64-100			
	2525LL13-64H	○	○	25×25	150	21	4	13	64-100			
	2525LL22-64H	○	○	25×25	150	26	4	22	64-100			
	2020LL10-90H	○	○	20×20	150	21	4	10	90-140			
	2020LL15-90H	○	○	20×20	150	26	4	15	90-140			
	2525LL13-90H	○	○	25×25	150	21	4	13	90-140			
	2525LL22-90H	○	○	25×25	150	26	4	22	90-140			
	2020LL10-130H	○	○	20×20	150	21	4	10	130-230			
	2020LL15-130H	○	○	20×20	150	26	4	15	130-230			
	2525LL13-130H	○	○	25×25	150	21	4	13	130-230			
2525LL22-130H	○	○	25×25	150	26	4	22	130-230				

● ex stock · ab Lager ○ on demand · auf Anfrage

■ Axial grooving and turning tools · Axialstech- & Drehwerkzeug

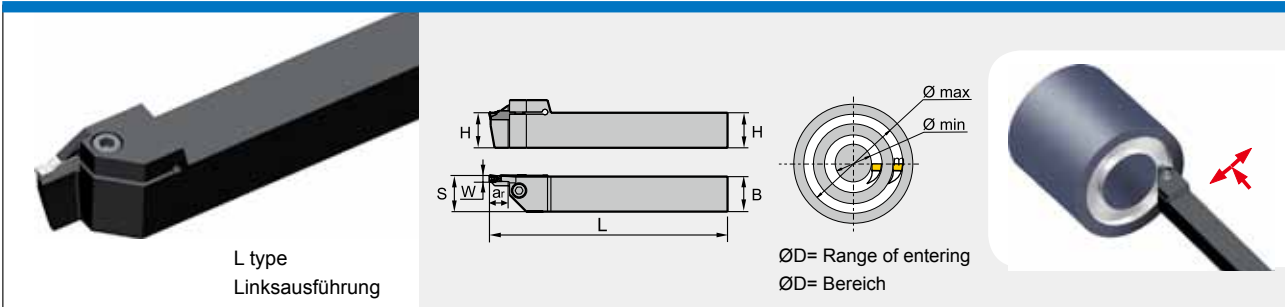

L type
Linksausführung

ØD= Range of entering
ØD= Bereich

Type · Typ		Stock		Dimension (mm) Abmessung						Inserts Stechplatten	Screw Schraube	Wrench Schlüssel
		R	L	H×B	L	S	W	a _r max	ØD (min-max)			
QFHD	2525LL13-58H	○	○	25×25	150	26	5	13	58-96	ZTHD0504-MG	GB70-85-M6×20	WH50L
	2525LL22-58H	○	○	25×25	150	26	5	22	58-96			
	2525LL13-86H	○	○	25×25	150	26	5	13	86-140			
	2525LL22-86H	○	○	25×25	150	26	5	22	86-140			
	2525LL13-130H	○	○	25×25	150	26	5	13	130-200			
	2525LL22-130H	○	○	25×25	150	26	5	22	130-200			
	2525LL13-185H	○	○	25×25	150	26	5	13	185-400			
	2525LL22-185H	○	○	25×25	150	26	5	22	185-400			
QFHS	2525LL30-185H	○	○	25×25	150	26	5	30	185-400	ZTHS0504-MG		
QFKD	2525LL13-60H	○	○	25×25	150	26	6	13	60-100	ZTKD0608-MG	GB70-85-M6×20	WH50L
	2525LL22-60H	○	○	25×25	150	26	6	22	60-100			
	2525LL13-88H	○	○	25×25	150	26	6	13	88-180			
	2525LL22-88H	○	○	25×25	150	26	6	22	88-180			
	2525LL13-160H	○	○	25×25	150	26	6	13	160-400			
	2525LL22-160H	○	○	25×25	150	26	6	22	160-400			
QFKS	2525LL30-160H	○	○	25×25	150	26	6	30	160-400	ZTKS0608-MG		

● ex stock · ab Lager ○ on demand · auf Anfrage

Turning · Drehen

Parting & Grooving · Ab- & Einstechen

L type tools for Axial grooving and turning · L Typ Axialstech- & Drehwerkzeug

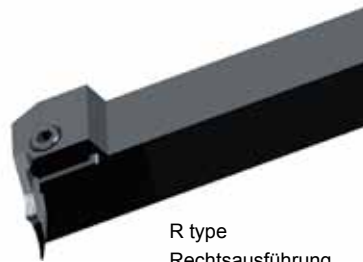

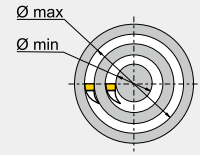
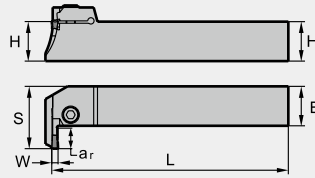

R type
Rechtsausführung



ØD = Range of entering
ØD = Bereich



Type · Typ		Stock		Dimension (mm) Abmessung					ØD (min-max)	Inserts Wendeschneidplatten	Screw Schraube	Wrench Schlüssel
		R	L	H×B	L	S	W	ar max				
QFFD	2020R/L7-48L	○	○	20×20	150	28.5	3	7	48-66	ZTFD0303-MG	GB70-85-M6×20	WH50L
	2020R/L10-48L	○	○	20×20	150	31.5	3	10	48-66			
	2525R/L10-48L	○	○	25×25	150	36.5	3	10	48-66			
	2525R/L17-48L	○	○	25×25	150	43.5	3	17	48-66			
	2020R/L7-60L	○	○	20×20	150	28.5	3	7	60-80			
	2020R/L10-60L	○	○	20×20	150	31.5	3	10	60-80			
	2525R/L10-60L	○	○	25×25	150	36.5	3	10	60-80			
	2525R/L17-60L	○	○	25×25	150	43.5	3	17	60-80			
	2020R/L7-74L	○	○	20×20	150	28.5	3	7	74-110			
	2020R/L10-74L	○	○	20×20	150	31.5	3	10	74-110			
	2525R/L10-74L	○	○	25×25	150	36.5	3	10	74-110			
	2525R/L17-74L	○	○	25×25	150	43.5	3	17	74-110			
	2020R/L7-100L	○	○	20×20	150	28.5	3	7	100-150			
	2020R/L10-100L	○	○	20×20	150	31.5	3	10	100-150			
2525R/L10-100L	○	○	25×25	150	36.5	3	10	100-150				
2525R/L17-100L	○	○	25×25	150	43.5	3	17	100-150				
QFGD	2020R/L10-52L	○	○	20×20	150	31.5	4	10	52-72	ZTGD0404-MG	GB70-85-M6×20	WH50L
	2525R/L13-52L	○	○	25×25	150	39.5	4	13	52-72			
	2020R/L15-52L	○	○	20×20	150	36.5	4	15	52-72			
	2525R/L22-52L	○	○	25×25	150	48.5	4	22	52-72			
	2020R/L10-64L	○	○	20×20	150	31.5	4	10	64-100			
	2525R/L13-64L	○	○	25×25	150	39.5	4	13	64-100			
	2020R/L15-64L	○	○	20×20	150	36.5	4	15	64-100			
	2525R/L22-64L	○	○	25×25	150	48.5	4	22	64-100			
	2020R/L10-90L	○	○	20×20	150	31.5	4	10	90-140			
	2525R/L13-90L	○	○	25×25	150	39.5	4	13	90-140			
	2020R/L15-90L	○	○	20×20	150	36.5	4	15	90-140			
	2525R/L22-90L	○	○	25×25	150	48.5	4	22	90-140			
	2020R/L10-130L	○	○	20×20	150	31.5	4	10	130-230			
	2525R/L13-130L	○	○	25×25	150	39.5	4	13	130-230			
2020R/L15-130L	○	○	20×20	150	36.5	4	15	130-230				
2525R/L22-130L	○	○	25×25	150	48.5	4	22	130-230				

● ex stock · ab Lager ○ on demand · auf Anfrage

L type tools for Axial grooving and turning · L Typ Axialstech- & Drehwerkzeug

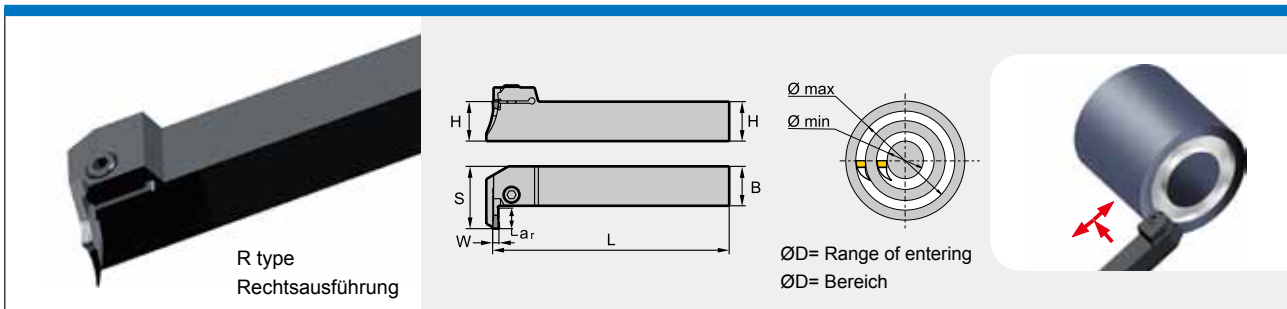

Type · Typ		Stock		Dimension (mm) Abmessung						Inserts Stechplatten	Screw Schraube	Wrench Schlüssel
		R	L	H×B	L	S	W	ar max	ØD (min-max)			
QFHD	2525R/L13-58L	○	○	25×25	150	39.5	5	13	58-96	ZTHD0504-MG	GB70-85-M6×20	WH50L
	2525R/L22-58L	○	○	25×25	150	48.5	5	22	58-96			
	2525R/L13-86L	○	○	25×25	150	39.5	5	13	86-140			
	2525R/L22-86L	○	○	25×25	150	48.5	5	22	86-140			
	2525R/L13-130L	○	○	25×25	150	39.5	5	13	130-200			
	2525R/L22-130L	○	○	25×25	150	48.5	5	22	130-200			
	2525R/L13-185L	○	○	25×25	150	39.5	5	13	185-400			
2525R/L22-185L	○	○	25×25	150	48.5	5	22	185-400				
QFHS	2525R/L30-185L	○	○	25×25	150	56.5	5	30	185-400	ZTHS0504-MG		
QFKD	2525R/L13-60L	○	○	25×25	150	39.5	6	13	60-100	ZTKD0608-MG	GB70-85-M6×20	WH50L
	2525R/L22-60L	○	○	25×25	150	48.5	6	22	60-100			
	2525R/L13-88L	○	○	25×25	150	39.5	6	13	88-180			
	2525R/L22-88L	○	○	25×25	150	48.5	6	22	88-180			

● ex stock · ab Lager ○ on demand · auf Anfrage

Turning · Drehen

Parting & Grooving · Ab- & Einstechen

Internal grooving and turning tools · Einstech- & Drehwerkzeuge (Innen)

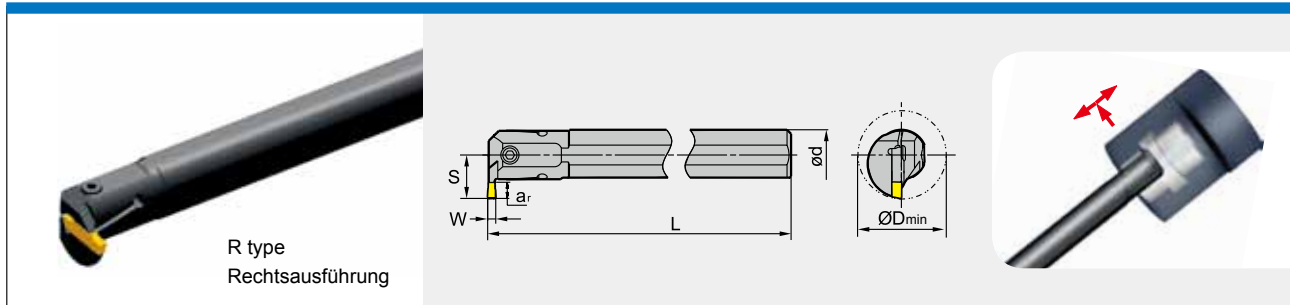

Type · Typ	Stock		Dimension (mm) Abmessung						Inserts Stechplatte	Screw Schraube	Wrench Schlüssel
	R	L	ød	L	S	W	ar _{max}	ØD _{min}			
C20Q-QEDR/L05-27	●	○	20	180	15.2	2.5	5	27	ZTED02* ZRED025*	GB70-85-M4×12	WH30L
C25R-QEDR/L07-33	●	●	25	200	20.3	2.5	7	33		GB70-85-M5×16	WH40L
C32S-QEDR/L09-42	●	●	32	250	25.3	2.5	9	42		GB70-85-M5×20	
C20Q-QFDR/L05-27	●	●	20	0	15.2	3	5	27	ZTFD03* ZRFD03*	GB70-85-M4×12	WH30L
C25R-QFDR/L07-33	●	●	25	200	20.3	3	7	33		GB70-85-M5×16	WH40L
C32S-QFDR/L09-42	●	●	32	250	25.3	3	9	42		GB70-85-M5×20	
C25R-QGDR/L08-35	●	●	25	200	21.5	4	8	35	ZTGD04* ZRGD04*	GB70-85-M5×16	WH40L
C32S-QGDR/L11-44	●	●	32	250	27.5	4	11	44		GB70-85-M6×20	WH50L
C40T-QGDR/L13-54	●	●	40	300	33.5	4	13	54		GB70-85-M6×20	
C25R-QHDR/L08-35	○	○	25	200	21.5	5	8	35	ZTHD05* ZRHD05*	GB70-85-M5×16	WH40L
C32S-QHDR/L11-44	●	●	32	250	27.5	5	11	44		GB70-85-M6×20	WH50L
C40T-QHDR/L13-54	●	○	40	300	33.5	5	13	54		GB70-85-M6×20	
C25R-QKDR/L08-35	○	○	25	200	21.5	6	8	35	ZTKD06* ZRKD06*	GB70-85-M5×16	WH40L
C32S-QKDR/L11-44	●	●	32	250	27.5	6	11	44		GB70-85-M6×20	WH50L
C40T-QKDR/L13-54	●	●	40	300	33.5	6	13	54		GB70-85-M6×20	

Profiling and turning tools for Al · Profildreh- & Einstechwerkzeuge für Alu (Innen)

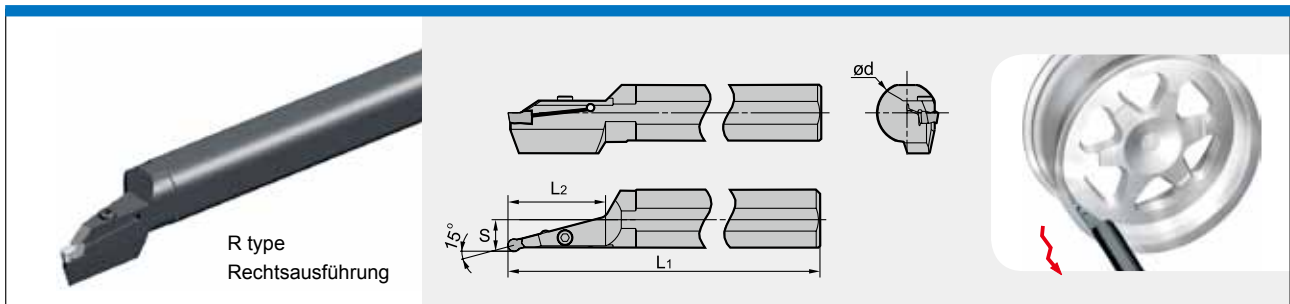

Type · Typ	Stock		Dimension (mm) Abmessung					Inserts Stechplatten	Screw Schraube	Wrench Schlüssel
	R	L	ØD ₀	ød	S	L1	L2			
C40X-QLDR/L65-15A	●	●	160	40	21	320	65	ZRLD08-LH	GB70-85-M6×20	WH50L
C40X-QLDR/L80-15A	●	○	160	40	21	320	80	ZRLD08-LH		
C40X-QKDR/L60-15A	○	○	160	40	20	320	60	ZRKD06-LH		
C40X-QKDR/L75-15A	○	○	160	40	20	320	75	ZRKD06-LH		

● ex stock · ab Lager ○ on demand · auf Anfrage

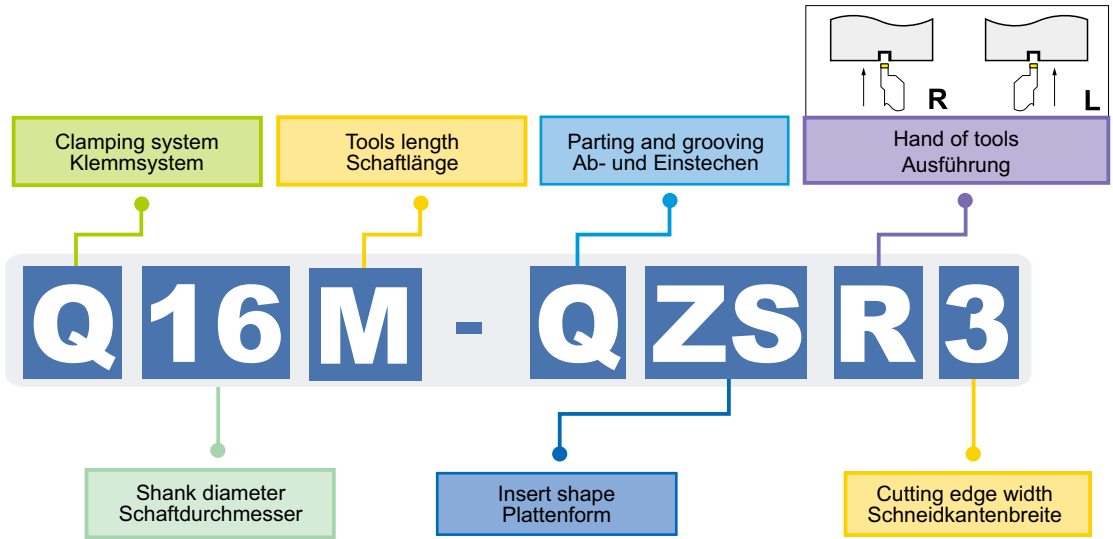
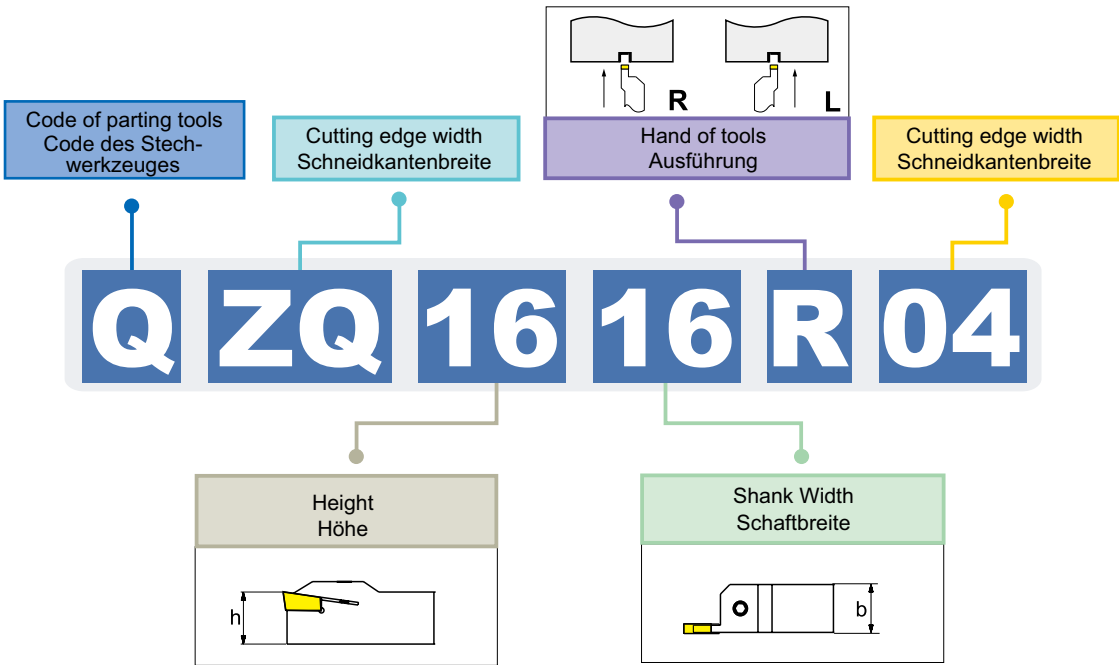



Turning · Drehen

Parting & Grooving · Ab- & Einstechen

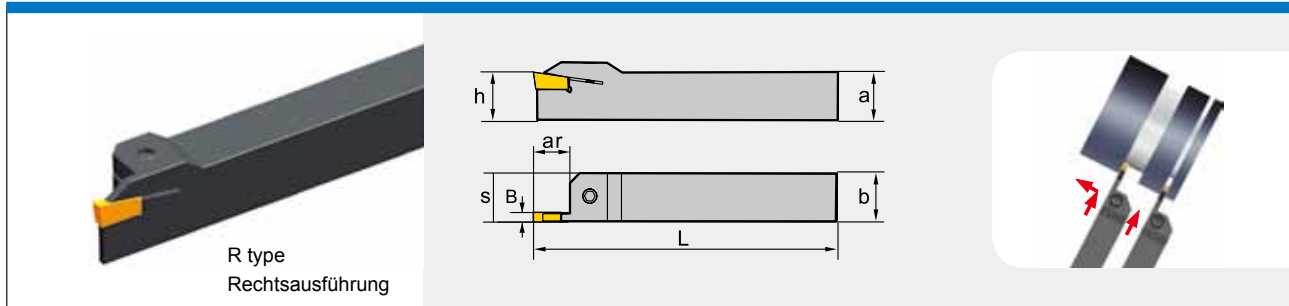
External parting and grooving · Ab- & Einstechwerkzeug (Außen): QZQ Series



R type
Rechtsausführung

Type · Typ		Stock		Dimension (mm) Abmessung						Inserts Stechplatten	Screw Schraube	Wrench Schlüssel
		R	L	a=h	b	L	S	B	a _{r max}			
QZQ	1616R/L03	●	●	16	16	100	16.4	3	16	ZQMX3N11-IE	GB70-85-M5×16	WH40L
	1616R/L04	○	○	16	16	100	16.4	4	18	ZQMX4N11-IE		
	2020R/L03	●	●	20	20	125	20.4	3	20	ZQMX3N11-IE		
	2020R/L04	●	●	20	20	125	20.4	4	20	ZQMX4N11-IE		
	2525R/L03	●	●	25	25	150	25.4	3	20	ZQMX3N11-IE	GB70-85-M6×20	WH50L
	2525R/L04	●	●	25	25	150	25.4	4	20	ZQMX4N11-IE		
	2525R/L05	●	●	25	25	150	25.4	5	25	ZQMX5N11-IE		
	2525R/L06	●	●	25	25	150	25.7	6	32	ZQMX6N11-IE		
	3225R/L03	●	○	32	25	170	25.4	3	25	ZQMX3N11-IE		
	3225R/L04	●	○	32	25	170	25.4	4	25	ZQMX4N11-IE		
	3225R/L05	●	○	32	25	170	25.4	5	25	ZQMX5N11-IE		
	3225R/L06	●	●	32	25	170	25.7	6	35	ZQMX6N11-IE		

● ex stock · ab Lager ○ on demand · auf Anfrage

Internal parting and grooving · Ab- & Einstechwerkzeug (Innen): QZS Series

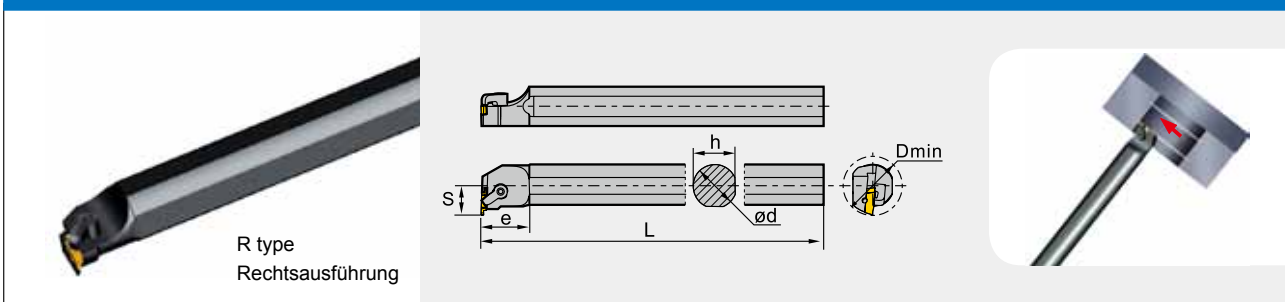

Type · Typ	Stock		Dimension (mm) Abmessung						Inserts Stechplatten	Screw Schraube	Wrench Schlüssel	Clamp Klemme
	R	L	L	h	S	e	ØD	ød				
C16M-QZSR3	○		150	15	11	17	20	16	ZS**3**L	DM5x14	WH25L	C4RD
C20M-QZSR3	○		150	18	13.5	22	26	20				
C25R-QZSR3	○		200	23	17	22	32	25				
C40T-QZSR3	○		300	37	27	32	50	40	ZSM*5**L			
C25R-QZSR5	○		200	23	17	2	20	25				
C40T-QZSR5	○		300	37	27	32	50	40	ZSM*3*R			
C16M-QZSL3		○	10	15	11	17	32	16				
C20M-QZSL3		○	150	18	13.5	22	26	20				
C25R-QZSL3		○	200	23	17	22	32	25				
C40T-QZSL3		○	300	37	27	32	50	40	ZSM*5*R			
C25R-QZSL5		○	200	23	17	22	32	25				
C40T-QZSL5		○	300	37	27	32	50	40				

External parting and grooving · Ab- & Einstechwerkzeug (Außen) : QZS Series

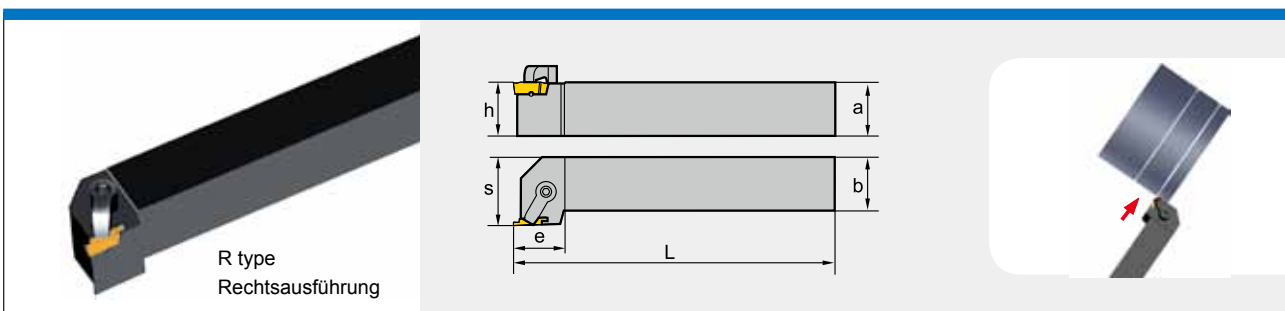

Type · Typ	Stock		Dimension (mm) Abmessung						Inserts Stechplatten	Screw Schraube	Wrench Schlüssel	Clamp Klemme
	R	L	a	b	L	h	s	e				
QZS2525R3	○		25	25	150	25	32	23.5	ZS**3***R	DM6x25	WH30L	C2RD
QZS2525R5	○		25	25	150	25	32	23.5	ZSM*5***R			
QZS2525L3		○	25	25	150	25	32	23.5	ZSM*3***L			
QZS2525L5		○	25	25	150	25	32	23.5	ZSM*5***L			

● ex stock · ab Lager ○ on demand · auf Anfrage



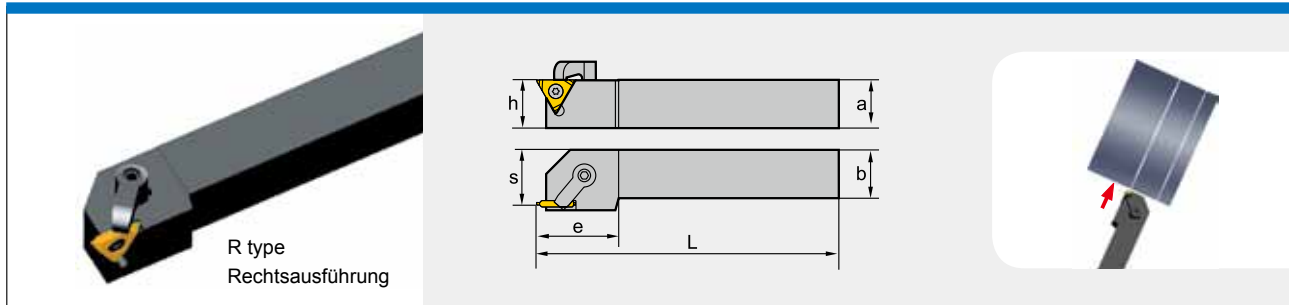

Turning · Drehen

Parting & Grooving · Ab- & Einstechen

External parting and grooving · Ab- & Einstechwerkzeug (Außen) : QT Series



R type
Rechtsausführung

Type · Typ	Stock		Dimension (mm) Abmessung					Inserts Stechplatten	Screw Schraube	Screw Schraube	Wrench Schlüssel	Clamp Klemme
	R	L	a	b	L	h	s					
QT2020R/L3	●		20	20	125	20	22	154.3-161	I90M3.5x8	DM6x25	WT09IP WH30L	C2RD
QT2020R/L4	●		20	20	125	20	21	154.3-163				
QT2525R/L3	●		25	25	150	25	27	154.3-162				
QT2525R/L4	●		25	25	150	25	26	154.3-164				

● ex stock · ab Lager ○ on demand · auf Anfrage

Center height controlling of parting and grooving tools Einstellung der Schneidhöhe beim Ab- & Einstechen

- No matter what kind of parting and grooving cutting tools you choose, you should keep 90° between the insert and the center line of the work-piece material to get perfect machined surface, and to reduce liberation during machining.
- Bitte montieren Sie den Werkzeughalter so, dass er im 90° Winkel zur Mittelachse des Werkstücks steht. Dadurch erhalten Sie eine bessere Oberflächengüte und verringern das Risiko von Schwingungen.
- Height tolerance between the cutting edge of an insert and the center of work piece should be kept $\pm 0.1\text{mm}$, especially for the parting of rods and grooving of materials with a small diameter. You achieve a longer tool lifetime and reduce cutting resistance and burrs.
- Bitte montieren Sie Ihren Werkzeughalter so, dass er beim Abstechen oder Einstechen speziell bei Werkstücken mit kleineren Durchmessern im Toleranzbereich von $\pm 0,1\text{ mm}$ zur Mittelachse steht. Sie erreichen dadurch eine längere Standzeit, reduzieren die Schnittkräfte und Butzenbildung.

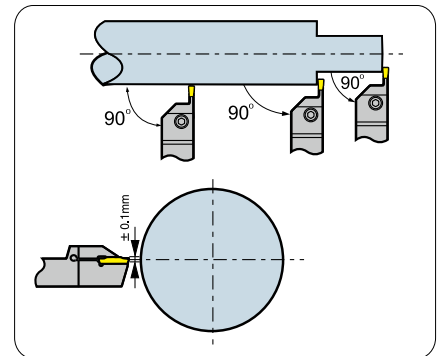

Parting · Abstechen

- A reduction of the feedrate by 30% is preferred when the inserts approach the centre of workpiece, prolonging the life-time of the inserts.
- Eine Reduzierung des Vorschubs um 30% bei der Annäherung der Schneide an die Mittelachse des Werkstücks verlängert die Standzeit der Stechplatte.
- A tool holder overhang with as little as possible to insure good stability.
- Werkzeughalter mit kleinstmöglichem Überhang wählen, um Vibrationen und Werkzeugablenkung zu vermeiden.

External grooving, turning and profile turning · Längsdrehen, Profildrehen

- Cutting sequences: As the cutting depth is bigger than 0.5mm, radial cutting (biggest cutting depth 0.75 x edge width of insert) radial backing 0.1mm axial feed oblique back axial cutting radial cutting to the depth require.
- Bearbeitungsfolge 0,5mm: Radialer Vorschub auf erforderliche Schnitttiefe (ap max. 0.75 x Schneidplattenbreite) radiales Zurücksetzen um 0.1 mm Längsdrehen zur gegenüberliegenden Schulter diagonales Zurücksetzen um 0.5mm nach außen axial Vorschub bis zum Startpunkt radialer Vorschub auf erforderliche Schnitttiefe usw.
- When cutting bottom border or chamfering, do what the sketch show, reducing liberation by the friction of cutting tools with chippings.
- Beim Drehen des Nutgrundes oder der Fase befolgen Sie die nebenstehenden Arbeitsschritte. Dies reduziert die Auslenkung des Werkzeuges und verhindert Schneidkantenausbrüche.

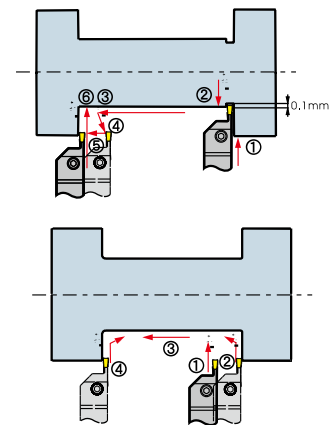

Surface grooving and turning · Axialeinstechen

Roughing · Schruppen

- Infeed from largest \varnothing inwards insert offset slightly from inner side of groove when retracting as shown in sketch (1).
- Bearbeitung vom größten \varnothing zur Achse hin. Beim Zurückfahren des Werkzeuges empfiehlt es sich, diese leicht abzuwinkeln.

Flute turning · Nutendrehen

- Depth of axial turning less than 0.75 x S (Width of insert)
width > depth of breaker, suggest to do as shown in sketch (2)
- Spantiefe bei axialem Vorschub kleiner als 0.75 x S (Breite des Schneideinsatzes)
Wenn die Kammerbreite größer ist als die Tiefe, folgen Sie den abgebildeten Arbeitsschritten. Wenn die Kammertiefe größer ist als die Breite, empfehlen wir in einzelnen Schritten auf den geforderten \varnothing zu stechen (2).

Finishing · Schlichten

- Finish machining external \varnothing and bottom firstly, then machining the internal \varnothing to the size required as shown in sketch (3).
- Zum Schlichten bearbeiten Sie zuerst den äußeren \varnothing und den Grund. Anschließend bearbeiten Sie den inneren \varnothing bis zur erforderlichen Größe Skizze (3).

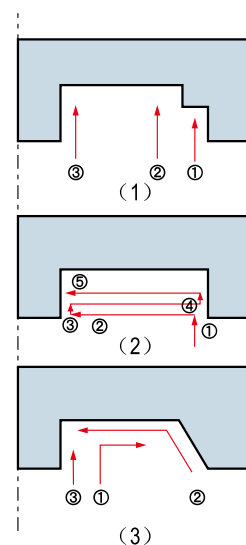

Turning · Drehen

Application Information · Anwendungsinformation

Internal grooving · Innenbearbeitung

• Follow the machining sequence as shown in the picture.
Good for chip flow, always feed along the direction of moving from the deepest in the hole to outside.

• Bearbeitungsfolge gemäß Skizze. Bei der Bearbeitung von Sackbohrungen, sollte zur besseren Spanabfuhr von innen nach außen gearbeitet werden.

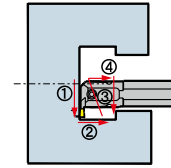

Recommended cutting parameters · Empfohlene Schnittparameter

Inserts Size Stechplatte Größe	Recommended feed rate (mm/rev) · Empfohlener Vorschub (mm/U)			
Inserts width(mm) Stechplatte Breite	Parting Abstechen	Grooving Einstechen	Turning Drehen	Profiling Profildrehen
2.5	0.05—0.15	0.05—0.15	0.05—0.15	0.05—0.15
3	0.05—0.15	0.05—0.15	0.07—0.15	0.1—0.2
4	0.05—0.2	0.05—0.2	0.07—0.25	0.1—0.2
5	0.07—0.2	0.07—0.22	0.1—0.25	0.15—0.3
6	0.1—0.3	0.07—0.25	0.1—0.3	0.15—0.3

Workpiece Material Werkstück Material		Hardness Härte	YBG302	YBG202	YBC151	YBC251	YD101	YD201	YBG102	YC10	YC40
P	Carbon steel Kohlenstoffstahl	125≤HB≤170	120-260	150-280	140-280	150-280				130-280	110-260
	Low alloy steel niedrig legierter Stahl	180≤HB≤275	80-175	110-200	100-240	110-200				90-200	70-175
	High alloy steel Hoch legierter Stahl	180≤HB≤325	80-160	110-190	100-220	110-190				90-190	70-160
	Cast steel Stahlguss	180≤HB≤250	75-140	100-170	80-160	100-170				80-170	60-140
M	Ferrite Martensite	200≤HB≤300	70-170	100-200		100-200				80-200	60-170
	Austenite	180≤HB≤300	80-200	110-220		110-220				90-220	70-200
K	Malleable cast iron Temperguss	130≤HB≤230	100-200	130-220				90-160			
	Grey cast iron Grauguss	180≤HB≤220	90-170	120-200				80-140			
	Nodular cast iron	160≤HB≤250	80-150	110-180				60-140			
N	Al alloy Alu-Legierung	--					200-400				
S	Heat resistant alloy hitzebeständigen Legierungen	≤400					20-50		30-60		

The cutting parameters recommended are suitable for wet machining.

Die angegebenen Schnittparameter werden für die Bearbeitung mit Kühlflüssigkeit empfohlen.

Advice: internal machining and Axial machining, The cutting speed should be reduced by 30%-40%.

Hinweis: Bei Innen- und Axialstechen, sollte die Schnittgeschwindigkeit um 30%-40% reduziert werden.

Turning · Drehen

Threading Tools · Gewindedreh Werkzeuge

Threading tools Overview · Klemmhalter zum Gewindedrehen Übersicht A292-A293

Introduction of threading inserts grade and chipbreaker A294
Sortenbeschreibung und Spanbrecher der Gewinde WSP

Threading inserts · Gewindedrehplatten A295-A302

Threading inserts code key · Gewindedrehplatten ISO Kennzeichen A295

ISO metric external thread ISO metrische Außengewinde A296

ISO metric internal thread ISO metrische Innengewinde A297

General pitch thread "General pitch" Gewinde A298

Whitworth thread "Whitworth" Gewinde A299

Unified thread "Unified" Gewinde A300

British standard taper pipe thread "British standard" Gewinde A301

American standard taper pipe thread "American standard" Gewinde A302

Threading tools · Gewindedrehwerkzeuge A303-A305

Threading tools code key · Gewindedrehwerkzeuge ISO Kennzeichen A303

External threading tools · Gewindedrehwerkzeuge (Außen) A304

Internal threading tools · Gewindedrehwerkzeuge (Innen) A305

Application information of threading A306-316
Anwendungsinformationen für das Gewindedrehen







Turning · Drehen



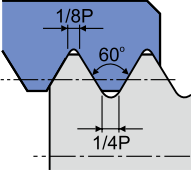
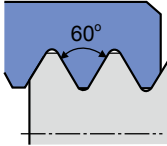
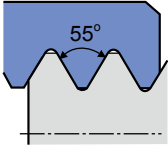

Threading tools Overview · Gewindedreh Werkzeuge Übersicht

A

Parting & Grooving · Ab- & Einstechen

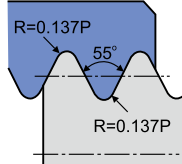
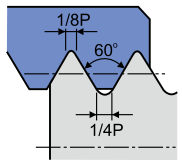
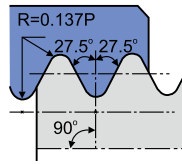
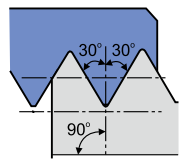
Threading · Gewindedrehen

Applications Anwendungen		For general Allgemein			
Cutline					
Thread name · Gewindebezeichnung		ISO metric thread Full profile Vollprofil	General pitch thread Partial profile Teilprofil	General pitch thread Partial profile Teilprofil	
Profil		GM	60°	55°	
Shape of insert WSP Abmessung (length/ Länge: 11, 16, 22mm)		Illustration: external thread right hand. Illustration: Außengewinde in Rechtsausführung.  A296-A297	Illustration: external thread right hand. Illustration: Außengewinde in Rechtsausführung.  A298	Illustration: external thread right hand. Illustration: Außengewinde in Rechtsausführung.  A298	
Toolholder Werkzeughalter	Pitch Steigung	Dimensions (mm) (H×W×L) (Dia.× Length × Min.Diameter)	Pitch/mm Steigung/mm (pitch/Inch)	Pitch/mm Steigung/mm (pitch/Inch)	Pitch/mm Steigung/mm (pitch/Inch)
	External thread · Außengewinde	 A290 16×16×100 20×20×125 25×25×150 32×25×170 32×32×170 40×40×250	1.0~6.0	0.5~5.0 (5~48)	0.5~5.0 (5~48)
Internal thread · Innengewinde	 A291 16×125×12 16×150×16 16×150×20 20×150×25 20×180×25 25×150×32 32×200×40 32×250×40 40×300×50 50×350×63	1.0~6.0	0.5~5.0 (5~48)	0.5~5.0 (5~48)	

Applications Anwendung	For general Allgemein	For aerospace and aviation industries Luft- & Raumfahrt	Pipe thread for heater, gas and water Rohrgewinde für: Dampf, Gas & Heizung	For connecting between pipe fitting and coupling of gas and water Für Gas & Wasser Fittings und Kupplungen
Cutline				
Thread name Gewindebez.	Whitworth thread /Gewinde	Unified thread (American standard threads)	British standard taper pipe threads	American standard taper pipe threads
Profil	W	UN	BSPT	NPT
Shape of insert WSP Abmessung (length/Länge: 11, 16, 22mm)	Illustration: external thread right hand. Illustration: Außengewinde in Rechtsausführung.  A299	Illustration: external thread right hand. Illustration: Außengewinde in Rechtsausführung.  A300	Illustration: external thread right hand. Illustration: Außengewinde in Rechtsausführung.  A301	Illustration: external thread right hand. Illustration: Außengewinde in Rechtsausführung.  A302
Dimensions (mm) (H×W×L) (Dia. × Length × Min. Diameter)	Pitch/mm Steigung/mm (pitch/Inch)	Pitch/mm Steigung/mm (pitch/Inch)	Pitch/mm Steigung/mm (pitch/Inch)	Pitch/mm Steigung/mm (pitch/Inch)
External thread · Außengewinde	16×16×100 20×20×125 25×25×150 32×25×170 32×32×170 40×40×250 8~16	8~20	11~28	8~27
Internal thread · Innengewinde	16×125×12 16×150×16 16×150×20 20×150×25 20×180×25 25×150×32 32×200×40 32×250×40 40×300×50 50×350×63 8~16	8~20	11~28	8~27

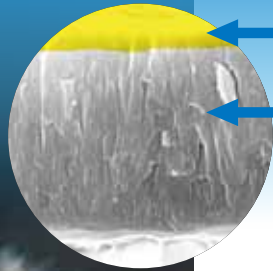
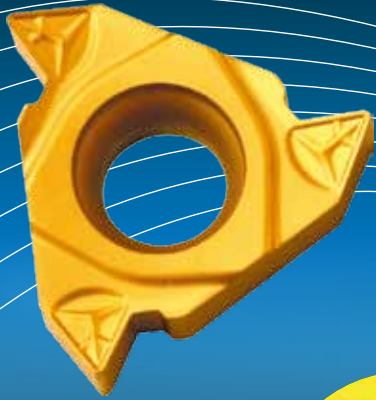

The golden TiN Coating reduces friction and provides wear identification.
Die goldene TiN Beschichtung reduziert die Reibung und ermöglicht die Verschleiß Identifikation.

Inner layer nc-TiAlN coating provides an excellent wear resistance.
Die innere Beschichtung nc-TiAlN ermöglicht eine exzellente Verschleißfestigkeit.

YBG201

PVD coating alloy has good toughness and wear resistance, it's the **unique** threading grade for machining of carbon steel, stainless steel and cast iron etc.

PVD Multibeschichtung mit hoher Härte und Verschleißfestigkeit. Es ist die ZCC Gewindesorte für die Bearbeitung von Kohlenstoff-, rostfreien Stahl und Grauguss. etc.

The functions and applications of Wiper for threading inserts Die Funktionen und Anwendungen der Wiper Schneidplatten

Reduction of machining processes.
The threading diameter will be machined during threading operation. Good quality and dimensions.

Reduziert die Bearbeitungsschritte.
Der Gewindedurchmesser wird während des Gewindegewindeschneidens in einem Arbeitsgang bearbeitet. Gute Oberfläche und Maßhaltigkeit.

Design characteristics chip breaker Spezielle Spanbrecherform

The ZCC CT Chip-breaker

The special chip breaker design ensured an excellent chip controlled, during machining **different** materials.

Der ZCC CT Spanbrecher

Der speziell entwickelter Spanbrecher formt und kontrolliert die Spanbildung in der Form, dass auch bei der Bearbeitung unterschiedlicher Werkstückstoffe, eine exzellente Spankontrolle entsteht.



Threading inserts code key Kennzeichnung für Gewindeplatten

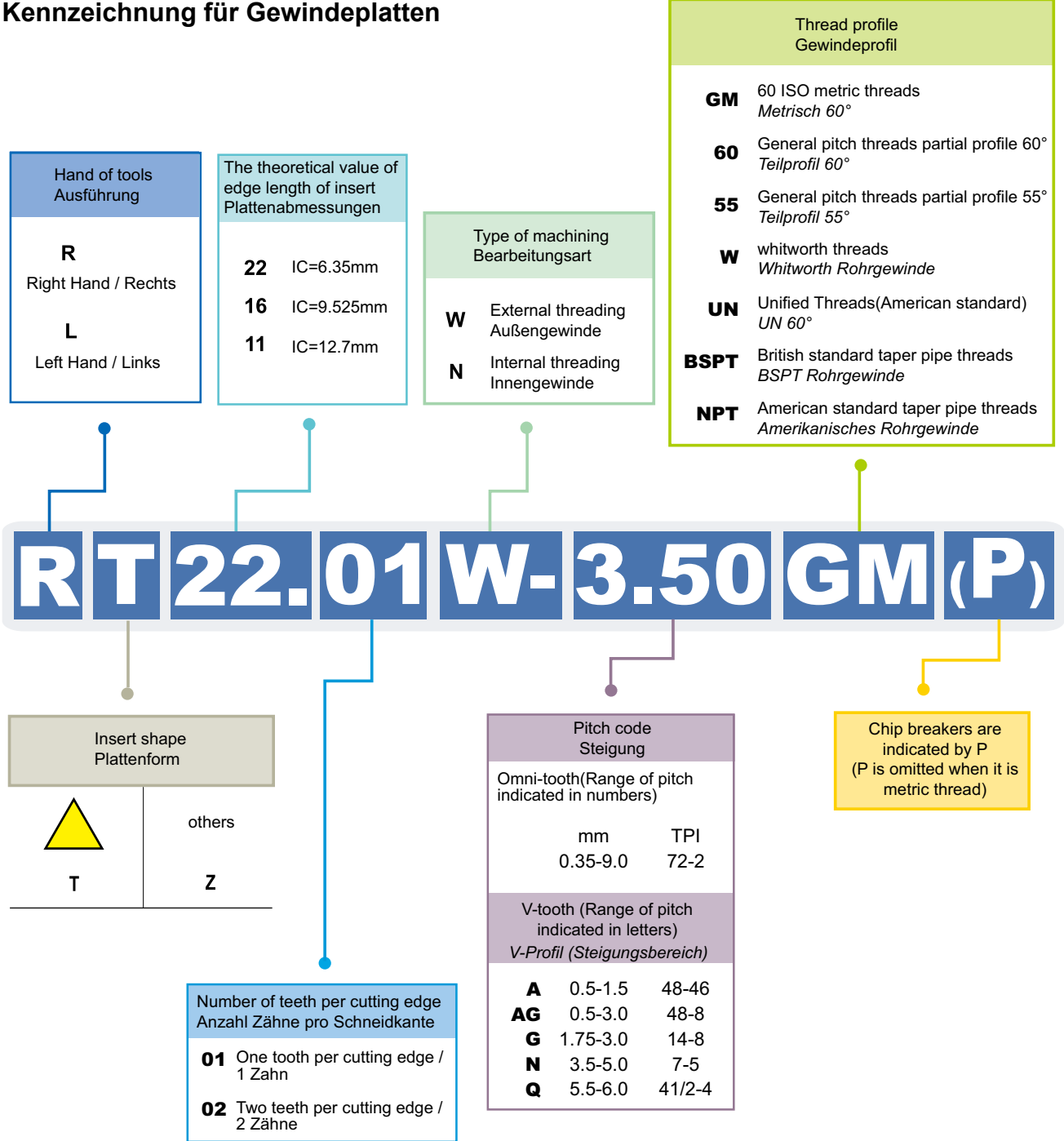

Turning · Drehen

Threading tools · Gewindedrehwerkzeuge

ISO metric thread insert (full profil)
Allgemeiner Einsatz (Vollprofil)

ISO 965-1980 DIN 13
GB-T 197-2003 tolerances: 6g-6H

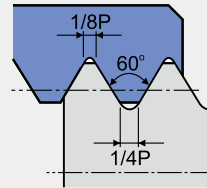

R

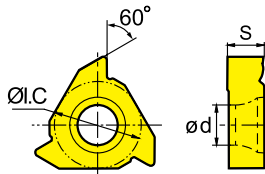

L

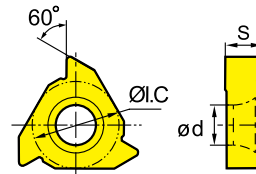

	Type · Typ		Dimension (mm) Abmessung				Grade · Sorte	
	Right hand Rechtsausführung	Left hand Linksausführung	Pitch · Steigung (T.P.i)	S	ØI.C	ød	YBG201	
							R	L
External · Außen	RT16.01W-1.00GM	LT16.01W-1.00GM	1.00	3.97	9.525	4.4	●	●
	RT16.01W-1.25GM	LT16.01W-1.25GM	1.25	3.97	9.525	4.4	●	●
	RT16.01W-1.50GM	LT16.01W-1.50GM	1.50	3.97	9.525	4.4	●	●
	RT16.01W-1.75GM	LT16.01W-1.75GM	1.75	3.97	9.525	4.4	●	●
	RT16.01W-2.00GM	LT16.01W-2.00GM	2.00	3.97	9.525	4.4	●	●
	RT16.01W-2.50GM	LT16.01W-2.50GM	2.50	3.97	9.525	4.4	●	●
	RT16.01W-3.00GM	LT16.01W-3.00GM	3.00	3.97	9.525	4.4	●	●
	RT22.01W-3.50GM	LT22.01W-3.50GM	3.50	5.56	12.7	5.5	●	●
	RT22.01W-4.00GM	LT22.01W-4.00GM	4.00	5.56	12.7	5.5	●	●
	RT22.01W-4.50GM	LT22.01W-4.50GM	4.50	5.56	12.7	5.5	●	○
	RT22.01W-5.00GM	LT22.01W-5.00GM	5.00	5.56	12.7	5.5	●	●
	RT22.01W-5.50GM	LT22.01W-5.50GM	5.50	5.56	12.7	5.5	●	○
RT22.01W-6.00GM	LT22.01W-6.00GM	6.00	5.56	12.7	5.5	●	●	

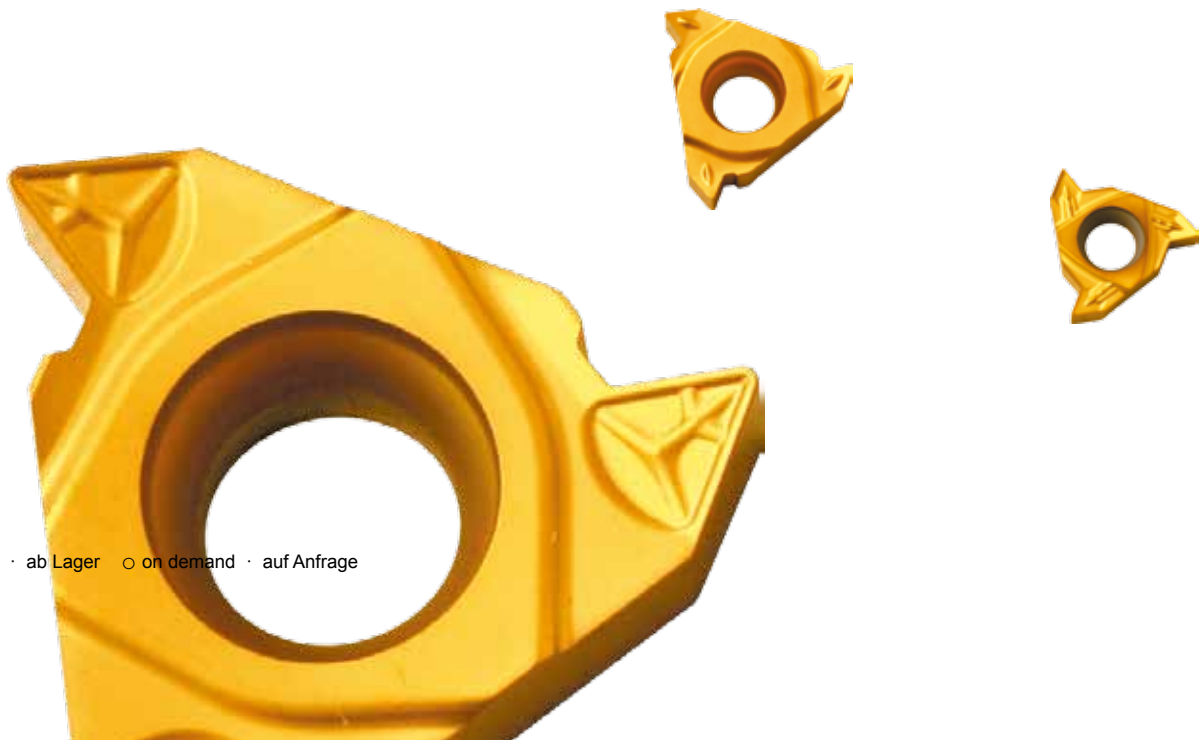

● ex stock · ab Lager ○ on demand · auf Anfrage

ISO metric thread insert (full profil)
Allgemeiner Einsatz (Vollprofil)

ISO 965-1980 DIN 13
GB·T 197-2003 tolerances: 6g·6H

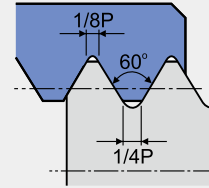

R

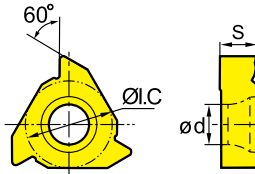

L

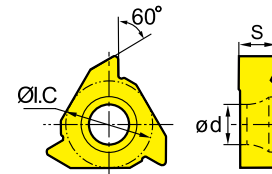

	Type · Typ		Dimension (mm) Abmessung				Grade · Sorte	
	Right hand Rechtsausführung	Left hand Linksausführung	Pitch·Steigung (T.P.I.)	S	ØI.C	ød	YBG201	
							R	L
Internal-Innen	RT11.01N-1.00GM	LT11.01N-1.00GM	1.00	3.18	6.35	2.8	●	●
	RT11.01N-1.25GM	LT11.01N-1.25GM	1.25	3.18	6.35	2.8	●	●
	RT11.01N-1.50GM	LT11.01N-1.50GM	1.50	3.18	6.35	2.8	●	●
	RT11.01N-1.75GM	LT11.01N-1.75GM	1.75	3.18	6.35	2.8	●	○
	RT11.01N-2.00GM	LT11.01N-2.00GM	2.00	3.18	6.35	2.8	●	●
	RT16.01N-1.00GM	LT16.01N-1.00GM	1.00	3.97	9.525	4.4	●	●
	RT16.01N-1.25GM	LT16.01N-1.25GM	1.25	3.97	9.525	4.4	●	●
	RT16.01N-1.50GM	LT16.01N-1.50GM	1.50	3.97	9.525	4.4	●	●
	RT16.01N-1.75GM	LT16.01N-1.75GM	1.75	3.97	9.525	4.4	●	●
	RT16.01N-2.00GM	LT16.01N-2.00GM	2.00	3.97	9.525	4.4	●	●
	RT16.01N-2.50GM	LT16.01N-2.50GM	2.5	3.97	9.525	4.4	●	●
	RT16.01N-3.00GM	LT16.01N-3.00GM	3.00	3.97	9.525	4.4	●	●
	RT22.01N-3.50GM	LT22.01N-3.50GM	3.50	5.56	12.7	5.5	●	●
	RT22.01N-4.00GM	LT22.01N-4.00GM	4.00	5.56	12.7	5.5	●	●
	RT22.01N-4.50GM	LT22.01N-4.50GM	4.50	5.56	12.7	5.5	●	●
	RT22.01N-5.00GM	LT22.01N-5.00GM	5.00	5.56	12.7	5.5	●	●
RT22.01N-5.50GM	LT22.01N-5.50GM	5.50	5.56	12.7	5.5	●	○	
RT22.01N-6.00GM	LT22.01N-6.00GM	6.00	5.56	12.7	5.5	●	●	

● ex stock · ab Lager ○ on demand · auf Anfrage

Turning · Drehen

Threading tools · Gewindedrehwerkzeuge

General pitch thread insert (partial profil)
Allgemeiner Einsatz (Teilprofil)

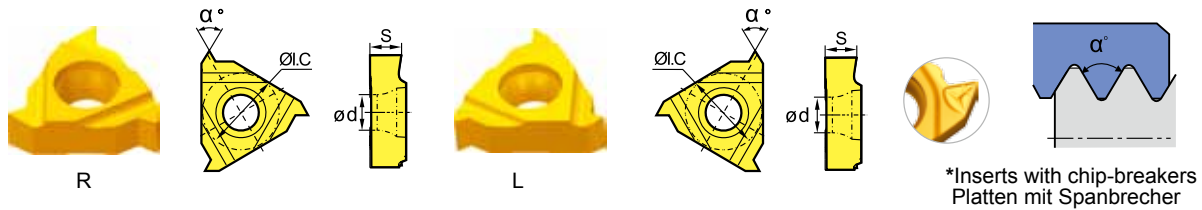

		Type · Typ		Dimension (mm) Abmessung					Grade · Sorte	
		Right hand Rechtsausführung	Left hand Linksausführung	Pitch · Steigung (T.P.i)	S	ØI.C	ød	α°	YBG201	
		R	L						R	L
External · Außen	60°	RT16.01W-A60	LT16.01W-A60	0.5-1.5(48-16)	3.97	9.525	4.4	60°	●	●
		RT16.01W-G60	LT16.01W-G60	1.75-3.0(14-8)	3.97	9.525	4.4	60°	●	●
		RT16.01W-G60P*	LT16.01W-G60P*	1.75-3.0(14-8)	3.97	9.525	4.4	60°	○	●
		RT16.01W-AG60	LT16.01W-AG60	0.5-3.0(48-8)	3.97	9.525	4.4	60°	●	●
		RT22.01W-N60	LT22.01W-N60P*	3.5-5.0(7-5)	5.56	12.7	5.5	60°	●	○
	55°	RT16.01W-A55	LT16.01W-A55	0.5-1.5(48-16)	3.97	9.525	4.4	55°	○	●
		RT16.01W-G55	LT16.01W-G55	1.75-3.0(14-8)	3.97	9.525	4.4	55°	●	●
		RT16.01W-G55P*	LT16.01W-G55P*	1.75-3.0(14-8)	3.97	9.525	4.4	55°	●	●
		RT16.01W-AG55	LT16.01W-AG55	0.5-3.0(48-8)	3.97	9.525	4.4	55°	●	○
		RT22.01W-N55P*	LT22.01W-N55	3.5-5.0(7-5)	5.56	12.7	5.5	55°	○	○

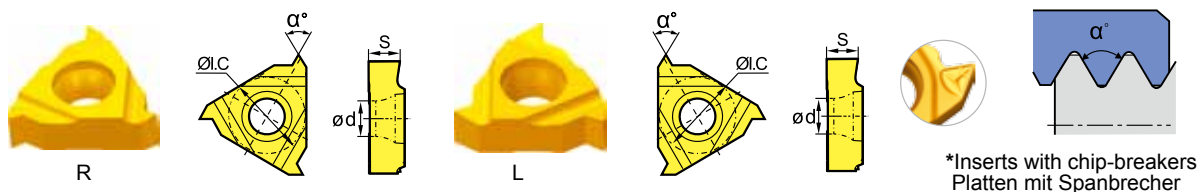

		Type · Typ		Dimension (mm) Abmessung					Grade · Sorte	
		Right hand Rechtsausführung	Left hand Linksausführung	Pitch · Steigung (T.P.i)	S	ØI.C	ød	α°	YBG201	
		R	L						R	L
Internal · Innen	60°	RT16.01N-A60	LT16.01N-A60	0.5-1.5 (48-16)	3.97	9.525	4.4	60°	●	○
		RT16.01N-G60	LT16.01N-G60	1.75-3.0	3.97	9.525	4.4	60°	●	○
		RT16.01N-G60P*	LT16.01N-G60P*	1.75-3.0	3.97	9.525	4.4	60°	○	○
		RT16.01N-AG60	LT16.01N-AG60	0.5-3.0 (48-8)	3.97	9.525	4.4	60°	●	○
		RT22.01N-N60	LT22.01N-N60	3.5-5.0 (7-5)	5.56	12.7	5.5	60°	○	○
	55°	RT16.01N-A55	LT16.01N-A55	0.5-1.5(48-16)	3.97	9.525	4.4	55°	○	○
		RT16.01N-G55	LT16.01N-G55	1.75-3.0(14-8)	3.97	9.525	4.4	55°	●	○
		RT16.01N-G55P*	LT16.01N-G55P*	1.75-3.0(14-8)	3.97	9.525	4.4	55°	●	●
		RT16.01N-AG55	LT16.01N-AG55	0.5-3.0(48-8)	3.97	9.525	4.4	55°	○	●
		RT22.01N-N55	LT22.01N-N55	3.5-5.0(7-5)	5.56	12.7	5.5	55°	○	○

● ex stock · ab Lager ○ on demand · auf Anfrage

Withworth thread insert
Withworth Rohrgewinde

ISO 228-1:1982,
DIN 259, B.S.84:1956
tolerances:Medium class A

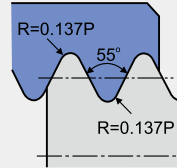

R

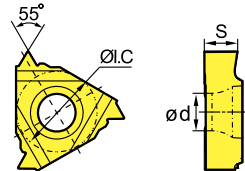

L

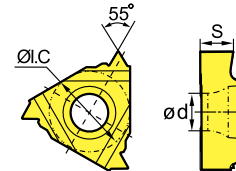

	Type · Typ		Dimension (mm) Abmessung				Grade · Sorte	
	Right hand Rechtsausführung	Left hand Linksausführung	Pitch · Steigung (T.P.i)	S	ØI.C	ød	YBG201	
							R	L
External · Außen	RT16.01W-8W	LT16.01W-8W	8	3.97	9.525	4.4	●	●
	RT16.01W-9W	LT16.01W-9W	9	3.97	9.525	4.4	●	●
	RT16.01W-10W	LT16.01W-10W	10	3.97	9.525	4.4	●	●
	RT16.01W-11W	LT16.01W-11W	11	3.97	9.525	4.4	●	●
	RT16.01W-12W	LT16.01W-12W	12	3.97	9.525	4.4	●	●
	RT16.01W-14W	LT16.01W-14W	14	3.97	9.525	4.4	●	●
	RT16.01W-16W	LT16.01W-16W	16	3.97	9.525	4.4	●	●



R

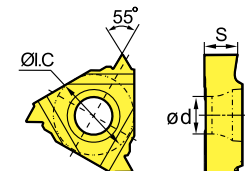

L

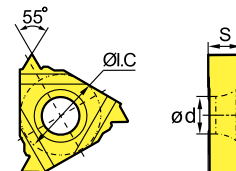

	Type · Typ		Dimension (mm) Abmessung				Grade · Sorte	
	Right hand Rechtsausführung	Left hand Linksausführung	Pitch · Steigung (T.P.i)	S	ØI.C	ød	YBG201	
							R	L
Internal · Innen	RT16.01N-8W	LT16.01N-8W	8	3.97	9.525	4.4	●	●
	RT16.01N-9W	LT16.01N-9W	9	3.97	9.525	4.4	●	●
	RT16.01N-10W	LT16.01N-10W	10	3.97	9.525	4.4	●	●
	RT16.01N-11W	LT16.01N-11W	11	3.97	9.525	4.4	●	●
	RT16.01N-12W	LT16.01N-12W	12	3.97	9.525	4.4	●	●
	RT16.01N-14W	LT16.01N-14W	14	3.97	9.525	4.4	●	●
	RT16.01N-16W	LT16.01N-16W	16	3.97	9.525	4.4	●	●

● ex stock · ab Lager ○ on demand · auf Anfrage

Turning · Drehen

Threading tools · Gewindedrehwerkzeuge

UN full profile · UN Vollprofil

ASME B1.1-1989
tolerances: 2A · 2B

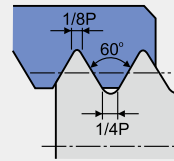

R

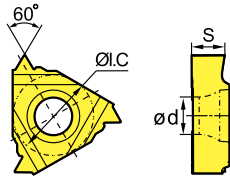

L

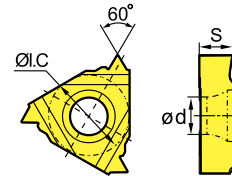

	Type · Typ		Dimension (mm) Abmessung				Grade · Sorte	
	Right hand Rechtsausführung	Left hand Linksausführung	Pitch · Steigung (T.P.i)	S	ØI.C	ød	YBG201	
							R	L
External · Außen	RT16.01W-8UN	LT16.01W-8UN	8	3.97	9.525	4.4	○	○
	RT16.01W-10UN	LT16.01W-10UN	10	3.97	9.525	4.4	●	●
	RT16.01W-12UN	LT16.01W-12UN	12	3.97	9.525	4.4	●	●
	RT16.01W-14UN	LT16.01W-14UN	14	3.97	9.525	4.4	●	●
	RT16.01W-16UN	LT16.01W-16UN	16	3.97	9.525	4.4	●	●
	RT16.01W-18UN	LT16.01W-18UN	18	3.97	9.525	4.4	●	●
	RT16.01W-20UN	LT16.01W-20UN	20	3.97	9.525	4.4	●	●



R

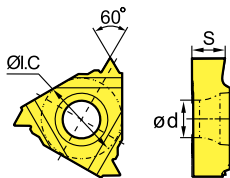

L

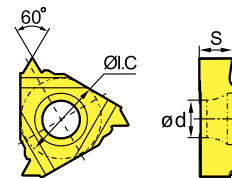

	Type · Typ		Dimension (mm) Abmessung				Grade · Sorte	
	Right hand Rechtsausführung	Left hand Linksausführung	Pitch · Steigung (T.P.i)	S	ØI.C	ød	YBG201	
							R	L
Internal · Innen	RT16.01N-8UN	LT16.01N-8UN	8	3.97	9.525	4.4	○	○
	RT16.01N-10UN	LT16.01N-10UN	10	3.97	9.525	4.4	●	●
	RT16.01N-12UN	LT16.01N-12UN	12	3.97	9.525	4.4	●	●
	RT16.01N-14UN	LT16.01N-14UN	14	3.97	9.525	4.4	●	●
	RT16.01N-16UN	LT16.01N-16UN	16	3.97	9.525	4.4	●	●
	RT16.01N-18UN	LT16.01N-18UN	18	3.97	9.525	4.4	●	●
	RT16.01N-20UN	LT16.01N-20UN	20	3.97	9.525	4.4	●	●

● ex stock · ab Lager ○ on demand · auf Anfrage

British standard taper pipe thread insert
Rohrgewinde für Dampf-, Gas- und Wasserleitungen

ISO 7·1:1994
B.S.21:1985
Standard BSPT

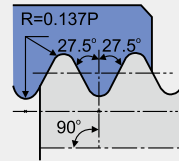

R

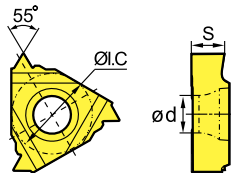

L

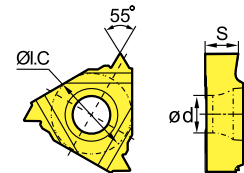

	Type · Typ		Dimension (mm) Abmessung				Grade · Sorte	
	Right hand Rechtsausführung	Left hand Linksausführung	Pitch · Steigung (T.P.i)	S	ØI.C	ød	YBG201	
							R	L
External · Außen	RT16.01W-11 BSPT	LT16.01W-11 BSPT	11	3.97	9.525	4.4	●	●
	RT16.01W-14 BSPT	LT16.01W-14 BSPT	14	3.97	9.525	4.4	●	●
	RT16.01W-19 BSPT	LT16.01W-19 BSPT	19	3.97	9.525	4.4	●	●
	RT16.01W-28 BSPT	LT16.01W-28 BSPT	28	3.97	9.525	4.4	●	●



R

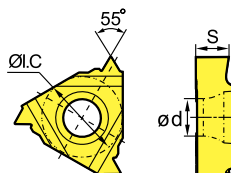

L

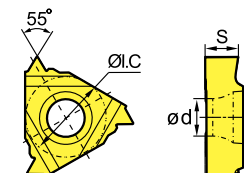

	Type · Typ		Dimension (mm) Abmessung				Grade · Sorte	
	Right hand Rechtsausführung	Left hand Linksausführung	Pitch · Steigung (T.P.i)	S	ØI.C	ød	YBG201	
							R	L
Internal · Innen	RT16.01N-11 BSPT	LT16.01N-11 BSPT	11	3.97	9.525	4.4	●	●
	RT16.01N-14 BSPT	LT16.01N-14 BSPT	14	3.97	9.525	4.4	●	●
	RT16.01N-19 BSPT	LT16.01N-19 BSPT	19	3.97	9.525	4.4	●	●
	RT16.01N-28 BSPT	LT16.01N-28 BSPT	28	3.97	9.525	4.4	●	●

● ex stock · ab Lager ○ on demand · auf Anfrage

Turning · Drehen

Threading tools · Gewindedrehwerkzeuge

NPT American standard taper pipe with a shoulder
Amerikanisches kegeliges Rohrgewinde

ASME B1.20.1-1983
Standard NPT

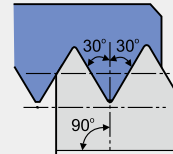

	Type · Typ		Dimension (mm) Abmessung				Grade · Sorte	
	Right hand Rechtsausführung	Left hand Linksausführung	Pitch-Steigung (T.P.i)	S	ØI.C	ød	YBG201	
							R	L
External · Außen	RT16.01W-8 NPT	LT16.01W-8NPT	8	3.97	9.525	4.4	○	○
	RT16.01W-11.5 NPT	LT16.01W-11.5NPT	11.5	3.97	9.525	4.4	○	○
	RT16.01W-14 NPT	LT16.01W-14NPT	14	3.97	9.525	4.4	○	○
	RT16.01W-18 NPT	LT16.01W-18NPT	18	3.97	9.525	4.4	○	○
	RT16.01W-27 NPT	LT16.01W-27NPT	27	3.97	9.525	4.4	○	○



	Type · Typ		Dimension (mm) Abmessung				Grade · Sorte	
	Right hand Rechtsausführung	Left hand Linksausführung	Pitch-Steigung (T.P.i)	S	ØI.C	ød	YBG201	
							R	L
Internal · Innen	RT16.01N-8 NPT	LT16.01N-8 NPT	8	3.97	9.525	4.4	○	○
	RT16.01N-11.5 NPT	LT16.01N-11.5 NPT	10	3.97	9.525	4.4	○	○
	RT16.01N-14 NPT	LT16.01N-14 NPT	12	3.97	9.525	4.4	○	○
	RT16.01N-18 NPT	LT16.01N-18 NPT	18	3.97	9.525	4.4	○	○
	RT16.01N-27 NPT	LT16.01N-27 NPT	20	3.97	9.525	4.4	○	○

● ex stock · ab Lager ○ on demand · auf Anfrage

Threading toolholders code key Kennzeichnung für Gewindehalter

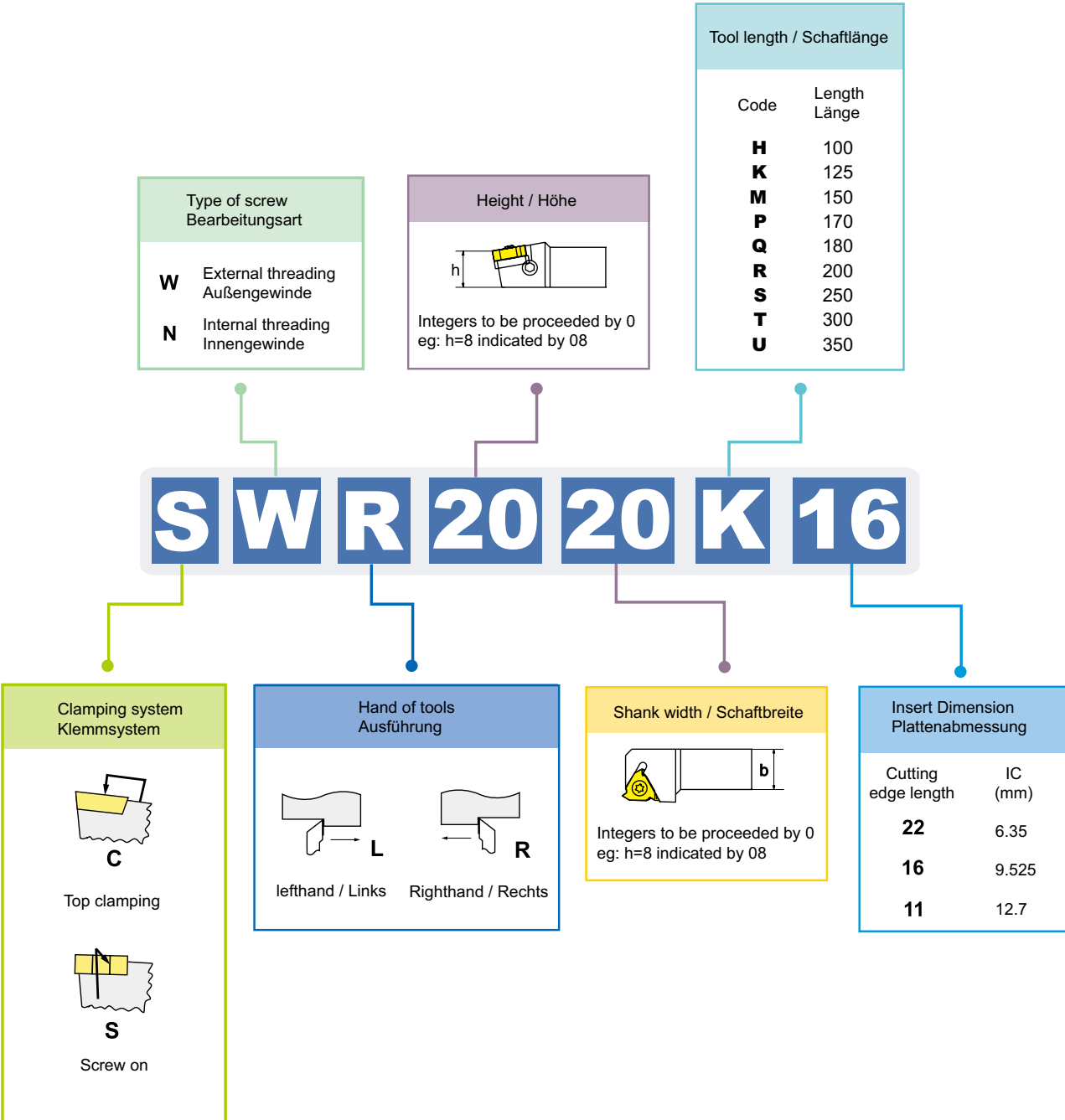

Turning · Drehen

Threading tools · Gewindedrehwerkzeuge

A

Parting & Grooving · Ab- & Einstechen

Threading · Gewindedrehen



External threading tools · Außengewindehalter

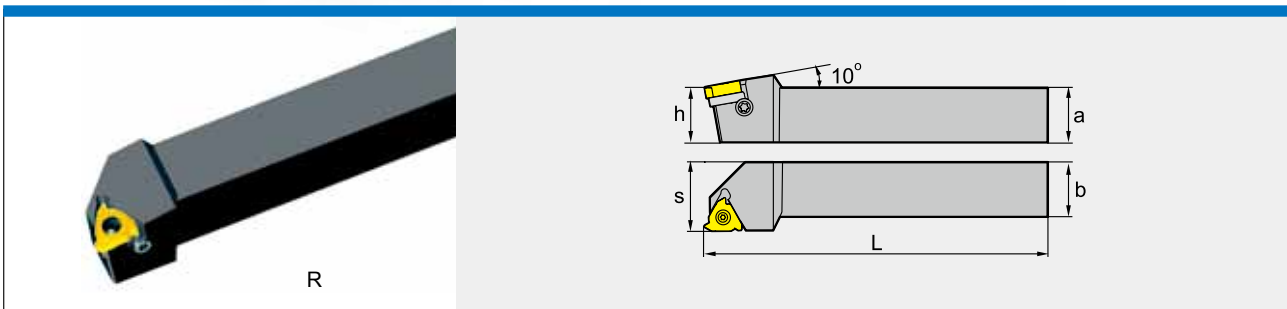

Type · Typ		Stock Lager	Dimension (mm) Abmessung					Inserts Wendschneidplatten	Screw Schraube	Shim Unterlage	Shim screw Schraube	Wrench Schlüssel					
			a	h	b	L	s										
SWR	1616H16	●	16	16	16	100	20	RT16.01W-****	I60M3.5×12	MT16-**M	SM4×8C	WT15IP					
	2020K16	●	20	20	20	125	25										
	2525M16	●	25	25	25	150	32										
	3225P16	●	32	32	25	170	32										
	3232P16	●	32	32	32	170	40										
	2525M22	●	25	25	25	150	32										
	3225P22	○	32	32	25	170	32										
	3232P22	●	32	32	32	170	40										
4040S22	○	40	40	40	250	50	RT22.01W-****	I60M5×17	MT22-**M	SM4×8C	WT15IP WT20IP						
SWL	1616H16	●	16	16	16	100						20	LT16.01W-****	I60M3.5×12	MT16-**M	SM4×8C	WT15IP
	2020K16	●	20	20	20	125						25					
	2525M16	●	25	25	25	150						32					
	3225P16	●	32	32	25	170						32					
	3232P16	○	32	32	32	170						40					
	2525M22	●	25	25	25	150						32					
	3225P22	○	32	32	25	170						32					
	3232P22	●	32	32	32	170	40										
4040S22	○	40	40	40	250	50	LT22.01W-****	I60M5×17	MT22-**M	SM4×8C	WT15IP WT20IP						

● ex stock · ab Lager ○ on demand · auf Anfrage

Internal threading tools · Innengewindehalter

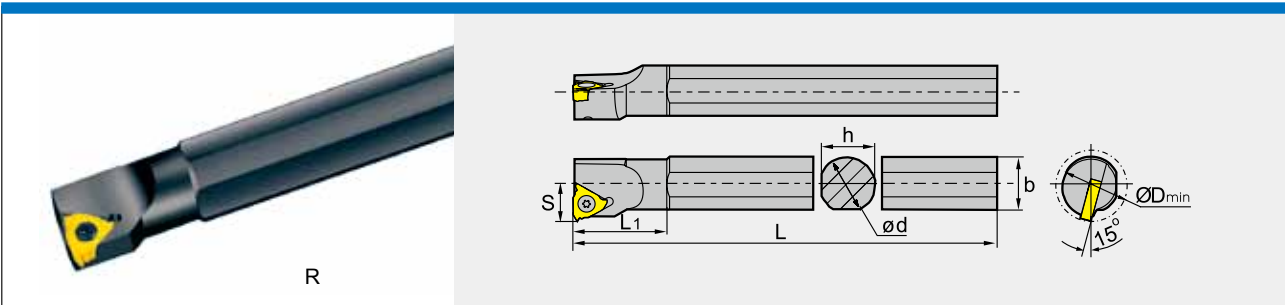

Type · Typ		Stock Lager	Dimension (mm) Abmessung							Inserts Wendeschneidplatten	Screw Schraube	Shim Unterlage	Shim screw Schraube	Wrench Schlüssel
			d	L	b	Dmin	s	h	L1					
SNR	0016K11	●	16	125	16	12	10	15	20.9	LT11.01N-****	I60 M2.5×6.5	---	---	WT07IP
	0016M11	●	16	150	15.5	16	10.5	15	25.9					
	0016M16	●	16	150	15.5	20	12	15	27					
	0020M16	●	20	150	19	25	14	18	28.7	LT16.01N-****	I60 M3.5×8	---	---	WT15IP
	0020Q16	●	20	180	19	25	14	18	34					
	0025M16	●	25	150	24	32	17	23	28.8					
	0032R16	●	32	200	31	40	22	30	30.9					
	0032S16	●	32	250	31	40	22	30	30.9					
	0040T16	●	40	300	38.5	50	27	37	31.5					
	0050U16	○	50	350	49.5	63	35	49	40.2	LT22.01N-****	I60 M5×10	---	---	WT20IP
	0020Q22	○	20	180	21.5	25	15	18	35					
	0025R22	●	25	200	24	32	19	23	39					
	0032S22	●	32	250	31	40	22	30	36.4					
	0040T22	○	40	300	38.5	50	27	37	37.2					
	0050U22	●	50	350	48.5	63	35	47	42.6	RT11.01N-****	I60 M5×17	MT22-**M	SM4×8C	WT15IP WT20IP
0016K11	●	16	125	16	12	10	15	20.9						
0016M11	●	16	150	15.5	16	10.5	15	25.9						
0016M16	●	16	150	15.5	20	12	15	27						
0020M16	○	20	150	19	25	14	18	28.7						
0020Q16	●	20	180	19	25	14	18	34						
0025M16	●	25	150	24	32	17	23	28.8						
0032R16	○	32	200	31	40	22	30	30.9						
0032S16	○	32	250	31	40	22	30	30.9						
0040T16	●	40	300	38.5	50	27	37	31.5						
0050U16	○	50	350	49.5	63	35	49	40.2						
0020Q22	○	20	180	21.5	25	15	18	35						
0025R22	○	25	200	24	32	19	23	39						
0032S22	○	32	250	31	40	22	30	36.4						
0040T22	○	40	300	38.5	50	27	37	37.2						
0050U22	●	50	350	48.5	63	35	47	42.6						

● ex stock · ab Lager ○ on demand · auf Anfrage

Turning · Drehen

Threading tools · Gewindedrehwerkzeuge

Steps to get the best threading result:

Bearbeitungsfolge für beste Ergebnisse beim Geschwindeschneiden:

- 1** Select thread machining method
Wahl der Gewindedrehmethode
- 2** Decide helical angle, select shim
Auswahl des Winkels und der Unterlage
- 3** Choose insert and toolholder size
Auswahl der Halter und Platten
- 4** By checking reference table of standard threading program, select feasible cutting parameters.
Auswahl der Schnittparameter
- 5** Select feed way
Auswahl der Schnitttrichtung

Thread machining method · Gewindedrehmethode

External threading machining (Right thread)
Außenbearbeitung (Rechtsausführung)

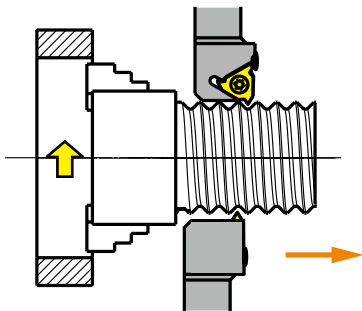
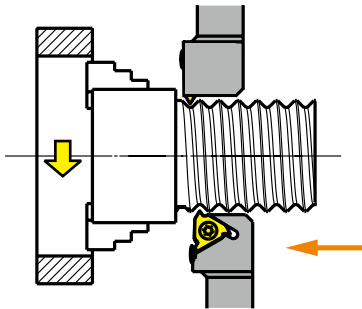

External threading machining (Left thread)
Außenbearbeitung (Linksausführung)

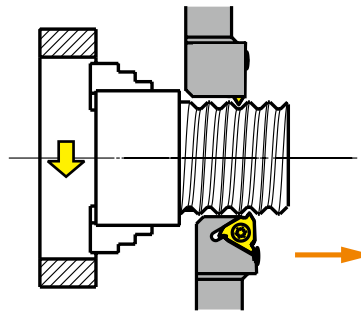
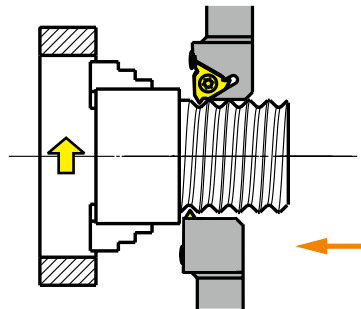

Internal threading machining (Right thread)
Innenbearbeitung (Rechtsausführung)

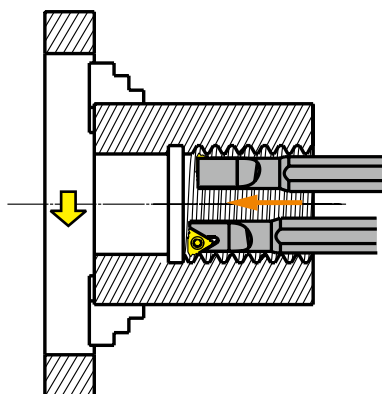

Internal threading machining (Left thread)
Innenbearbeitung (Linksausführung)

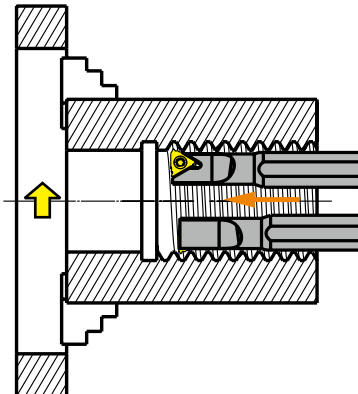

Decide helical angle, select shim · Auswahl des Winkels und der Unterlage

The flank clearance angles of the thread profile is dependent on the helix angle of the thread. The helix angle of the thread must coincide with the insert's angle of inclination angle as far as possible to get the ideal profile, to avoid longer unfavourable wear on one of the flanks and thus to ensure tool life.

Die Flankenfreiwinkel des Gewindeprofils sind vom Steigungswinkel des Gewindes abhängig. Der Steigungswinkel des Gewindes muss mit dem Neigungswinkel der Gewindeplatte soweit wie möglich übereinstimmen, um Profil-Genauigkeit zu erzielen, ungleichmäßigen Freiflächenverschleiß der Gewindeplatte zu vermeiden und eine längere Standzeit zu gewährleisten.

$$\lambda = \arctan \frac{p}{d_2 \times \pi}$$

Shim specification table are as following:
Wahl der Unterlegplatte

Screw pitch range Steigungs- bereich	Insert dimensions Abmessung	Inclined angle Neigungs- winkel	Shim Unterlage
0.5-3.0	16	0	MT16-00M
		1	MT16-01M
		2	MT16-02M
		3	MT16-03M
3.5-6.0	22	0	MT22-00M
		1	MT22-01M
		2	MT22-02M
		3	MT22-03M

Shim for $\lambda = 1^\circ$ is as the standard shim with the toolholder.

Die Unterlage $\lambda = 1^\circ$ wird mit dem Halter geliefert.

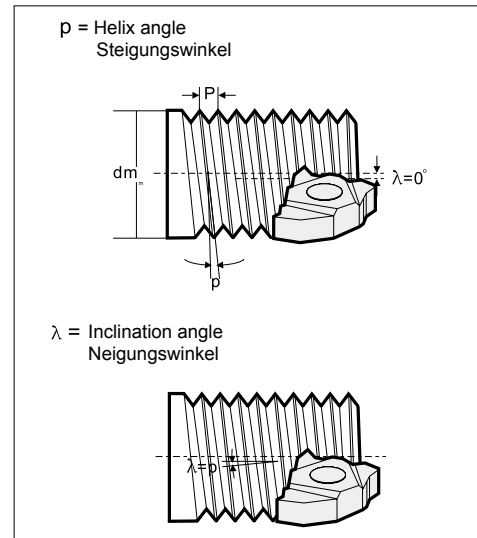

- p = Pitch
Steigung
- d₂ = Effective diameter of thread
Flankendurchmesser
- λ = Inclination angle
Neigungswinkel

Select shim:
Wahl der richtigen Unterlage:

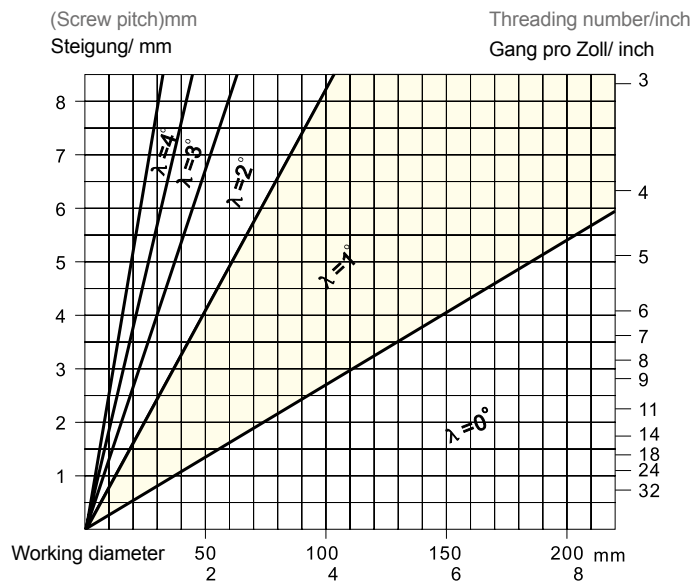

Turning · Drehen

Threading tools · Gewindedrehwerkzeuge

Select proper inserts and size of toolholder (Please refer to detailed table of threading tools and inserts)
Ausgewählt zweckmäßige Gewindeplatten und Haltergrößen

Parameter table for threading machining program under different conditions
Parametertabelle für das Gewindedrehprogramm für unterschiedliche Bedingungen

Table of recommended infeed for metric **ISO external threading with wiper edge**
Empfohlene Zustellungswerte für metrische **ISO Außengewinde mit Wiper**

Pitch(mm) / Steigung	1.0	1.25	1.5	1.75	2.0	2.5	3.0	4.0	5.0
Total feed (a) Gesamtzustellung	0.72	0.86	1.02	1.17	1.33	1.63	1.94	2.58	3.21
Cutting times(nap) Anzahl der Schnitte	5	6	7	8	9	11	13	15	17
Cutting order Schnittaufteilung	Radial X · Axial Z								
	X/Z	X/Z	X/Z	X/Z	X/Z	X/Z	X/Z	X/Z	X/Z
1	0.20/-	0.20/-	0.21/-	0.22/-	0.24/-	0.25/-	0.26/-	0.35/-	0.40/-
2	0.18/0.10	0.18/0.10	0.18/0.10	0.20/0.12	0.22/0.13	0.24/0.14	0.24/0.14	0.30/0.17	0.35/0.20
3	0.16/0.09	0.14/0.09	0.18/0.10	0.18/0.10	0.20/0.12	0.21/0.12	0.20/0.12	0.25/0.14	0.30/0.17
4	0.10/0.06	0.10/0.08	0.15/0.09	0.15/0.09	0.15/0.09	0.18/0.10	0.20/0.12	0.20/0.12	0.28/0.16
5	0.08/-	0.08/0.06	0.12/0.07	0.13/0.08	0.12/0.07	0.15/0.09	0.18/0.10	0.18/0.10	0.25/0.14
6			0.10/0.06	0.11/0.06	0.12/0.07	0.12/0.07	0.15/0.09	0.18/0.10	0.20/0.12
7			0.08/-	0.10/0.06	0.10/0.06	0.12/0.07	0.13/0.08	0.16/0.09	0.18/0.10
8				0.08/-	0.10/0.06	0.10/0.06	0.12/0.07	0.15/0.09	0.16/0.09
9					0.08/-	0.10/0.06	0.10/0.06	0.15/0.09	0.15/0.09
10						0.08/0.05	0.10/0.06	0.13/0.08	0.15/0.09
11						0.08/-	0.08/0.06	0.12/0.07	0.13/0.08
12							0.08/0.05	0.12/0.07	0.13/0.08
13								0.11/0.06	0.12/0.07
14								0.10/0.06	0.12/0.07
15								0.08/-	0.11/0.06
16									0.10/0.06
17									0.08/-

- Table of recommended infeed for metric **ISO internal threading with wiper edge**
Empfohlene Zustellungswerte für metrische **ISO Innengewinde mit Wiper**

Pitch(mm) / Steigung	1.00	1.25	1.5	1.75	2.0	2.5	3.0	4.0	5.0
Total feed (a) Gesamtzustellung	0.62	0.77	0.92	1.06	1.21	0.15	1.79	2.36	2.95
Cutting times(nap) Anzahl der Schnitte	5	6	7	8	9	11	13	15	17
Cutting order Schnittaufteilung	Radial X · Axial Z								
	X/Z	X/Z	X/Z	X/Z	X/Z	X/Z	X/Z	X/Z	X/Z
1	0.18/-	0.20/-	0.22/-	0.23/-	0.24/-	0.25/-	0.26/-	0.30/-	0.32/-
2	0.14/0.08	0.15/0.09	0.16/0.09	0.16/0.09	0.18/0.10	0.20/0.12	0.20/0.12	0.25/0.14	0.28/0.16
3	0.12/0.07	0.12/0.07	0.14/0.08	0.14/0.08	0.15/0.09	0.15/0.09	0.20/0.12	0.22/0.13	0.25/0.14
4	0.10/0.06	0.12/0.07	0.12/0.07	0.13/0.08	0.14/0.08	0.15/0.09	0.18/0.10	0.20/0.12	0.22/0.13
5	0.08/-	0.10/0.06	0.11/0.06	0.12/0.07	0.12/0.07	0.13/0.08	0.15/0.09	0.18/0.10	0.21/0.12
6			0.09/0.05	0.10/0.06	0.11/0.06	0.12/0.07	0.12/0.07	0.15/0.09	0.20/0.12
7			0.08/-	0.10/0.06	0.10/0.06	0.12/0.07	0.12/0.07	0.15/0.09	0.18/0.10
8				0.08/-	0.09/0.05	0.10/0.06	0.10/0.06	0.15/0.09	0.18/0.10
9					0.08/-	0.10/0.06	0.10/0.06	0.12/0.07	0.15/0.09
10						0.09/0.05	0.10/0.06	0.12/0.07	0.15/0.09
11						0.08/-	0.10/0.06	0.12/0.07	0.15/0.09
12							0.08/0.05	0.11/0.06	0.15/0.09
13								0.11/0.06	0.12/0.07
14								0.10/0.06	0.11/0.06
15								0.08/-	0.10/0.06
16									0.10/0.06
17									0.08/-



Turning · Drehen

Threading tools · Gewindedrehwerkzeuge

Table of recommended infeed for **American unified standard external threading inserts**
 Empfohlene Zustellungswerte für **American unified standard Außengewinde Schneidplatten**

Pitch (mm) Steigung	24	20	18	16	14	12	11	10	9	8	7	6	5
Total feed (a)/ Gesamtzustellung	0.649	0.779	0.866	0.974	1.113	1.299	1.416	1.558	1.731	1.948	2.226	2.597	3.116
Cutting times (nap) Anzahl der Schnitte	5	6	6	7	9	9	10	11	12	13	14	15	16
Cutting order Schnittaufteilung	Radial X · Axial Z												
	X/Z	X/Z	X/Z	X/Z	X/Z	X/Z	X/Z	X/Z	X/Z	X/Z	X/Z	X/Z	X/Z
1	0.206 /— —	0.210 /— —	0.233 /— —	0.226 /— —	0.196 /— —	0.229 /— —	0.220 /— —	0.214 /— —	0.210 /— —	0.211 /— —	0.213 /— —	0.218 /— —	0.229 /— —
2	0.148 /0.086	0.163 /0.094	0.181 /0.104	0.188 /0.109	0.189 /0.110	0.222 /0.128	0.228 /0.132	0.240 /0.139	0.256 /0.148	0.276 /0.160	0.304 /0.176	0.343 /0.198	0.399 /0.230
3	0.114 /0.066	0.125 /0.072	0.139 /0.080	0.145 /0.083	0.146 /0.084	0.170 /0.098	0.176 /0.102	0.184 /0.106	0.196 /0.113	0.212 /0.122	0.234 /0.135	0.263 /0.152	0.306 /0.177
4	0.096 /0.055	0.105 /0.061	0.117 /0.068	0.122 /0.070	0.123 /0.071	0.143 /0.083	0.148 /0.086	0.155 /0.090	0.165 /0.095	0.179 /0.103	0.197 /0.114	0.222 /0.128	0.258 /0.149
5	0.085 /0.049	0.093 /0.054	0.103 /0.059	0.107 /0.062	0.108 /0.062	0.126 /0.073	0.131 /0.075	0.137 /0.079	0.146 /0.084	0.158 /0.091	0.173 /0.100	0.195 /0.113	0.227 /0.131
6		0.084 /0.048	0.093 /0.054	0.097 /0.056	0.098 /0.056	0.114 /0.066	0.118 /0.068	0.124 /0.072	0.132 /0.076	0.142 /0.082	0.157 /0.091	0.177 /0.102	0.205 /0.119
7				0.089 /0.052	0.090 /0.052	0.105 /0.061	0.109 /0.063	0.114 /0.066	0.121 /0.070	0.131 /0.076	0.144 /0.083	0.163 /0.094	0.189 /0.109
8					0.084 /0.048	0.098 /0.056	0.101 /0.058	0.106 /0.061	0.113 /0.065	0.122 /0.070	0.134 /0.078	0.151 /0.087	0.176 /0.101
9					0.079 /0.045	0.092 /0.053	0.095 /0.055	0.100 /0.057	0.106 /0.061	0.114 /0.066	0.126 /0.073	0.142 /0.082	0.165 /0.095
10							0.090 /0.052	0.094 /0.054	0.100 /0.058	0.108 /0.063	0.119 /0.069	0.134 /0.078	0.156 /0.090
11								0.090 /0.052	0.095 /0.055	0.103 /0.059	0.113 /0.065	0.128 /0.074	0.149 /0.086
12									0.091 /0.053	0.098 /0.057	0.108 /0.063	0.122 /0.071	0.142 /0.082
13										0.094 /0.054	0.104 /0.060	0.117 /0.068	0.136 /0.079
14											0.100 /0.058	0.113 /0.065	0.131 /0.076
15												0.109 /0.063	0.126 /0.073
16													0.122 /0.071

Turning · Drehen

Threading tools · Gewindedrehwerkzeuge

Table of recommended infeed for **American unified standard internal threading inserts**
 Empfohlene Zustellungswerte für **American unified standard Innengewinde Schneidplatten**

Pitch (mm) Steigung	24	20	18	16	14	12	11	10	9	8	7	6	5
Total feed (a)/ Gesamtzustellung	0.573	0.687	0.764	0.860	0.982	1.146	1.250	1.375	1.528	1.719	1.964	2.291	2.750
Cutting times(nap) Anzahl der Schnitte	5	6	6	7	8	9	9	10	11	12	13	14	15
Cutting order Schnittaufteilung	Radial X · Axial Z												
	X/Z	X/Z	X/Z	X/Z	X/Z	X/Z	X/Z	X/Z	X/Z	X/Z	X/Z	X/Z	X/Z
1	0.193 /—	0.200 /—	0.222 /—	0.219 /—	0.220 /—	0.228 /—	0.250 /—	0.247 /—	0.246 /—	0.252 /—	0.262 /—	0.278 /—	0.302 /—
2	0.127 /0.073	0.239 /0.081	0.155 /0.089	0.161 /0.093	0.173 /0.100	0.190 /0.110	0.207 /0.120	0.216 /0.125	0.229 /0.132	0.247 /0.142	0.271 /0.156	0.304 /0.176	0.353 /0.204
3	0.098 /0.056	0.107 /0.062	0.119 /0.069	0.124 /0.072	0.132 /0.076	0.146 /0.084	0.159 /0.092	0.166 /0.096	0.176 /0.101	0.189 /0.109	0.208 /0.120	0.234 /0.135	0.271 /0.156
4	0.082 /0.048	0.090 /0.052	0.100 /0.058	0.104 /0.060	0.112 /0.064	0.123 /0.071	0.134 /0.077	0.140 /0.081	0.148 /0.086	0.160 /0.092	0.175 /0.101	0.197 /0.114	0.228 /0.132
5	0.073 /0.042	0.079 /0.046	0.088 /0.051	0.092 /0.053	0.098 /0.057	0.108 /0.062	0.118 /0.068	0.123 /0.071	0.130 /0.075	0.141 /0.081	0.1543 /0.089	0.173 /0.100	0.201 /0.116
6		0.072 /0.041	0.080 /0.046	0.083 /0.048	0.089 /0.051	0.098 /0.056	0.107 /0.062	0.111 /0.064	0.118 /0.068	0.127 /0.073	0.140 /0.081	0.157 /0.091	0.182 /0.105
7				0.077 /0.044	0.082 /0.047	0.090 /0.052	0.098 /0.057	0.102 /0.059	0.108 /0.063	0.117 /0.067	0.128 /0.074	0.144 /0.083	0.167 /0.097
8					0.076 /0.044	0.084 /0.048	0.091 /0.053	0.095 /0.055	0.101 /0.058	0.109 /0.063	0.119 /0.069	0.134 /0.078	0.156 /0.090
9						0.079 /0.045	0.086 /0.050	0.090 /0.052	0.095 /0.055	0.102 /0.059	0.112 /0.065	0.126 /0.073	0.146 /0.084
10								0.085 /0.049	0.090 /0.052	0.097 /0.056	0.106 /0.061	0.119 /0.069	0.138 /0.080
11									0.085 /0.049	0.092 /0.053	0.101 /0.058	0.113 /0.065	0.131 /0.076
12										0.088 /0.051	0.096 /0.056	0.108 /0.063	0.126 /0.073
13											0.092 /0.053	0.101 /0.060	0.121 /0.070
14												0.100 /0.058	0.116 /0.067
15													0.112 /0.065

A

Parting & Grooving · Ab- & Einstechen

Threading · Gewindedrehen

Turning · Drehen

Threading tools · Gewindedrehwerkzeuge

Table of recommended infeed for **British standard internal and external threading inserts**
 Empfohlene Zustellungswerte für **British Standard Innen- und Außengewinde Schneidplatten**

Pitch(mm) Steigung	28	20	19	16	14	12	11	10	9	8	7	6	5
Total feed (a) Gesamtzustellung	0.581	0.813	0.856	1.017	1.162	1.355	1.479	1.626	1.807	2.033	2.324	2.711	3.253
Cutting times(nap) Anzahl der Schnitte	5	6	6	8	8	9	9	10	11	12	14	15	16
Cutting order Schnittaufteilung	Radial X · Axial Z												
	x/z	x/z	x/z	x/z	x/z	x/z	x/z	x/z	x/z	x/z	x/z	x/z	x/z
1	0.179 / —	0.211 / —	0.223 / —	0.196 / —	0.223 / —	0.226 / —	0.246 / —	0.236 / —	0.230 / —	0.255 / —	0.195 / —	0.197 / —	0.204 / —
2	0.134 / 0.070	0.172 / 0.089	0.181 / 0.094	0.186 / 0.097	0.213 / 0.111	0.234 / 0.122	0.255 / 0.133	0.226 / 0.139	0.282 / 0.147	0.304 / 0.158	0.322 / 0.167	0.361 / 0.189	0.421 / 0.219
3	0.104 / 0.054	0.132 / 0.069	0.139 / 0.072	0.143 / 0.074	0.163 / 0.085	0.180 / 0.093	0.197 / 0.102	0.206 / 0.106	0.216 / 0.113	0.233 / 0.121	0.247 / 0.128	0.278 / 0.145	0.323 / 0.168
4	0.087 / 0.045	0.111 / 0.058	0.117 / 0.061	0.120 / 0.063	0.138 / 0.072	0.151 / 0.079	0.165 / 0.086	0.172 / 0.090	0.182 / 0.095	0.197 / 0.102	0.208 / 0.108	0.234 / 0.122	0.272 / 0.142
5	0.077 / 0.040	0.098 / 0.051	0.103 / 0.054	0.106 / 0.055	0.121 / 0.063	0.133 / 0.069	0.145 / 0.076	0.152 / 0.079	0.161 / 0.084	0.173 / 0.090	0.183 / 0.095	0.207 / 0.108	0.240 / 0.125
6		0.089 / 0.046	0.093 / 0.049	0.096 / 0.050	0.110 / 0.057	0.121 / 0.063	0.131 / 0.068	0.137 / 0.071	0.145 / 0.076	0.157 / 0.082	0.166 / 0.086	0.187 / 0.097	0.217 / 0.113
7				0.088 / 0.046	0.101 / 0.052	0.111 / 0.058	0.121 / 0.063	0.126 / 0.066	0.134 / 0.070	0.144 / 0.075	0.152 / 0.079	0.172 / 0.089	0.200 / 0.104
8				0.082 / 0.043	0.093 / 0.049	0.103 / 0.054	0.113 / 0.059	0.117 / 0.061	0.124 / 0.065	0.134 / 0.070	0.142 / 0.074	0.160 / 0.083	0.186 / 0.097
9						0.097 / 0.050	0.106 / 0.055	0.110 / 0.057	0.117 / 0.061	0.126 / 0.066	0.133 / 0.069	0.150 / 0.078	0.174 / 0.091
10								0.104 / 0.054	0.111 / 0.058	0.119 / 0.062	0.126 / 0.066	0.142 / 0.074	0.165 / 0.086
11									0.105 / 0.055	0.113 / 0.059	0.120 / 0.062	0.135 / 0.070	0.157 / 0.082
12										0.108 / 0.056	0.114 / 0.060	0.129 / 0.067	0.150 / 0.078
13											0.110 / 0.055	0.124 / 0.064	0.144 / 0.075
14												0.119 / 0.062	0.138 / 0.072
15												0.115 / 0.060	0.133 / 0.069

Table of recommended infeed for **NPT internal and external threading inserts**

Empfohlene Zustellungswerte für **NPT Innen- und Außengewinde Schneidplatten**

Pitch (mm) / Steigung	27	18	14	11.5	8
Total feed (a) / Gesamtzust.	0.75	1.129	1.451	1.767	2.54
Cutting times(nap) Anzahl der Schnitte	6	8	10	12	14
Cutting order Schnittaufteilung	Radial X · Axial Z				
	X/Z	X/Z	X/Z	X/Z	X/Z
1	0.19/-	0.22/-	0.240/-	0.24/-	0.255/-
2	0.15/0.087	0.181/0.104	0.200/0.115	0.208/0.120	0.250/0.144
3	0.13/0.075	0.152/0.088	0.170/0.098	0.182/0.105	0.245/0.141
4	0.11/0.063	0.141/0.081	0.150/0.086	0.168/0.097	0.230/0.133
5	0.09/0.052	0.131/0.075	0.140/0.081	0.155/0.089	0.210/0.121
6	0.08/0.46	0.121/0.070	0.130/0.075	0.145/0.084	0.195/0.112
7		0.101/0.058	0.120/0.069	0.138/0.079	0.180/0.104
8		0.082/0.047	0.110/0.063	0.124/0.072	0.175/0.101
9			0.100/0.058	0.117/0.067	0.170/0.098
10			0.091/0.052	0.105/0.060	0.155/0.089
11				0.095/0.055	0.140/0.080
12				0.090/0.052	0.125/0.072
13					0.110/0.063
14					0.100/0.058

Table of recommended infeed for **BSPT internal and external threading inserts**

Empfohlene Zustellungswerte für **BSPT Innen- und Außengewinde Schneidplatten**

Pitch (mm) / Steigung	28	19	14	11
Total feed (a) / Gesamtzust.	0.581	0.856	1.162	1.479
Cutting times(nap) Anzahl der Schnitte	5	6	8	10
Cutting order Schnittaufteilung	Radial X · Axial Z			
	X/Z	X/Z	X/Z	X/Z
1	0.179/-	0.223/-	0.222/-	0.214/-
2	0.134/0.070	0.181/0.094	0.213/0.111	0.242/0.126
3	0.103/0.054	0.139/0.072	0.163/0.085	0.186/0.097
4	0.087/0.045	0.117/0.061	0.138/0.072	0.157/0.082
5	0.078/0.040	0.103/0.054	0.121/0.063	0.138/0.072
6		0.093/0.049	0.110/0.057	0.125/0.065
7			0.101/0.052	0.115/0.060
8			0.094/0.049	0.107/0.056
9				0.100/0.052
10				0.095/0.049

Turning · Drehen

Threading tools · Gewindedrehwerkzeuge

■ Recommended Cutting parameters · Empfohlene Schnittparameter

ISO	Workpiece Material Werkstück Material		Hardness HB	Grade · Sorte	
				YBG201	
				Cutting speed(m·min) Schnittgeschwindigkeit (m·min)	
P	Carbon steel Kohlenstoffstahl	C=0.15%	125	150-175	
		C=0.35%	150	140-155	
		C=0.60%	200	130-145	
	Alloy steel legierter Stahl	Anneal	180	110-130	
Hardened		275	80-100		
Hardened		300	70-90		
	Hardened	350	60-80		
High alloy steel Hochlegierter Stahl	Anneal	200	90-115		
	Hardened	325	70-90		
Cast steel Gussstahl	Non-alloy low alloy high alloy Martensite steel 12%Mn	180	180-210		
		200	90-115		
		225	90-115		
		250	40-50		
M	Stainless steel Rostfreier Stahl	Austenite	180	110-130	
		Martensite-Ferrite	200	130-170	
K	Malleable cast iron Temperguss	Ferrite	130	110-140	
		Pearlite	230	85-105	
	Gray cast iron Grauguss	Low tensile-strength	180	110-140	
		High tensile-strength	260	90-115	
Nodular cast iron	Ferrite Pearlite	160	110-130		
		250	80-100		
N	Al alloy Aluminiumlegierung	Non-aging treatment	60	1300-1450	
		Aging treatment	100	450-500	
	Cast aluminum alloy Aluminium- gusslegierung	Non-aging treatment Aging treatment	75	430-470	
90			250-290		
S	Heat resistant alloy Hitzebeständige Legierung	Iron Base	Anneal	200	35-50
			Aging	280	25-35
		Ni- Or Co- base	Anneal	250	15-25
			Aging	350	10-20
	Casting	320	10-15		
H	Hardened steel gehärteter Stahl	Hardened steel	HRC55	40-50	

● ex stock · ab Lager ○ on demand · auf Anfrage

Infeed way of threading · Zustellarten beim Gewindedrehen

The Number of passes and infeed are the key points of threading operation. Please choose the cutting parameters with the recommended form according to experience data. In case of breakages or too much wear. Please have a look at page 302 (Troubleshooting).

Die Anzahl der Durchgänge und die Zustellungsgröße sind ein entscheidender Faktor bei der Gewindebearbeitung. Die empfohlenen Daten sind als Startwerte zu betrachten. Im Falle von erhöhtem Verschleiß, schauen Sie bitte auf Seite 302 (Problemlösung).

Radial infeed Radiale Zustellung

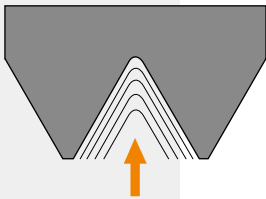

Radial infeed requires low cutting depth, sharp cutting edge and tough grade. It is recommended when the pitch is smaller than 2mm, not ideal for material with long chips.

Radiale Zustellung fordert eine niedrige Schnitttiefe, scharfe Schneidkante und zähe Sorte.

Modified flank infeed Modifizierte Flankenzustellung

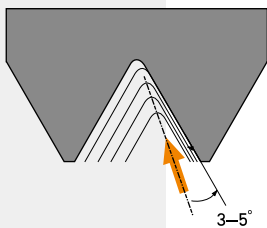

Infeed at an angle of 3-5° to the flank of the teeth. It is easy for chips flow. Suitable for long chip material and internal threading.

Zustellung unter einem Winkel von 3-5° zur Flanke des Gewindes, guter Spanablauf. Geeignet für langspanende Werkstoffe und Innengewinde.

Alternate flank infeed Wechselseitige Zustellung

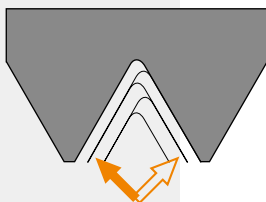

Alternating flank infeed is mainly used for large pitches and long chip materials. To get equal insert wear on both edges.

Wechselseitige Zustellung entlang beider Flanken. Anwendung bei großen Steigungen und langspanenden Werkstoffen. Gleichmäßiger Flankenverschleiß an beiden Schneidkanten.



Typical problem in threading and its solution Typische Probleme bei der Gewindebearbeitung und Lösungsvorschläge

Problem / Problemstellung	Cause / Ursache	Solution / Lösung
Big flank wear Großer Freiflächenverschleiß	Cutting speed too high / Schnittgeschwindigkeit zu hoch	Reduce cutting speed / Schnittgeschwindigkeit verringern
Asymmetric wear on left and right cutting edge Unterschiedliche Verschleißmarken an linker und rechter Seite	Infeed depth too small / Zustellung zu gering Inserts is over centre line / Platte steht über Mitte Incorrect method for flank infeed / Seitliche Zustellung nicht optimal	Reduce number of infeeds / Anzahl der Zustellungen verringern Adjust correct centre line / Plattenhöhe korrigieren Change method of flank infeed / Seitliche Zustellung korrigieren
Breakage / Bruch	Insert inclination angle does not correspond to the lead angle of the thread / Neigungswinkel und Hauptwinkel stehen nicht optimal zueinander Cutting speed too low / Schnittgeschwindigkeit zu niedrig Cutting force too big / Schnittkraft zu hoch	Change shim to obtain correct angle of inclination / Wechsel der Unterlage um korrekten Winkel zu erzeugen Increase cutting speed / Schnittgeschwindigkeit erhöhen Increase number of infeeds. Reduce size of the largest infeeds / Anzahl der Zustellungen erhöhen, Zustellgröße verringern
Plastic deformation / Plastische Deformation	Unstable condition / Instabile Verhältnisse Bad chip control	Check and improve clamping and tool overhang to prevent vibration / Werkstückspannung und Auskraglänge verbessern, um Vibrationen zu verhindern Increase pressure of cooling for better chip evacuation / Kühlmitteldruck erhöhen für bessere Spanabfuhr
Thread surface quality is poor / Oberflächenqualität des Gewindes nicht gut	Cutting speed and temperature too high / Schnittgeschwindigkeit und Temperatur zu hoch Insufficient cooling supply / Schlechte Kühlmittelzufuhr Cutting speed too low / Schnittgeschwindigkeit zu niedrig	Decrease cutting speed / Schnittgeschwindigkeit verringern Increase number of infeeds. Reduce size of the largest infeeds / Anzahl der Zustellungen erhöhen, Zustellgröße verringern Improve coolant supply / Kühlfuhr verbessern Increase cutting speed / Schnittgeschwindigkeit erhöhen
Incorrect profile / Gewindeprofil nicht korrekt	Inserts is over centre line / Platte steht über Mitte Bad chip control Wrong centre height / Plattenhöhe nicht korrekt	Adjust correct centre line / Plattenhöhe korrigieren Modified flank infeed / Zustellung verändern Change centre height / Plattenhöhe verändern
Shallow profile / Gewindeprofil	Toolholder not 90° to centre line / Halter steht nicht im 90° Winkel Pitch error in machine / Steigungsfehler der Maschine Wrong centre height / Plattenhöhe nicht korrekt Breakage of insert / Schneidkantenbruch Wear to big / Verschleiß zu groß Temperature on cutting edge too low / Temperatur an der Schneide zu gering	Adjust tool holder / Halter neu ausrichten Adjust machine / Maschine neu ausrichten Change centre height / Plattenhöhe verändern Change insert / Plattenwechsel Change insert / Plattenwechsel Increase cutting speed / Schnittgeschwindigkeit erhöhen
Build up edge / Aufbauschneidenbildung	Often occurs in low carbon or stainless steel / Oft bei der Bearbeitung von Kohlenstoffstahl oder rostfreiem Stahl Incorrect cutting parameter / Falsche Schnittparameter	Choose grade with good toughness (PVD coated) / Sorte mit ausreichend Zähigkeit verwenden (PVD beschichtet) Increase cutting speed or slow down cutting speed / Schnittgeschwindigkeit erhöhen oder stark verringern
Vibration / Vibrationen	Wrong centre height / Plattenhöhe nicht korrekt Clamping of work piece not good / Werkstückspannung nicht ausreichend	Change centre height / Plattenhöhe verändern Improve clamping system and minimize over hang / Spannsystem verbessern und Werkzeugauskragung minimieren

1. CUTTING TOOL GEOMETRIE · SCHNEIDENGEOMETRIE

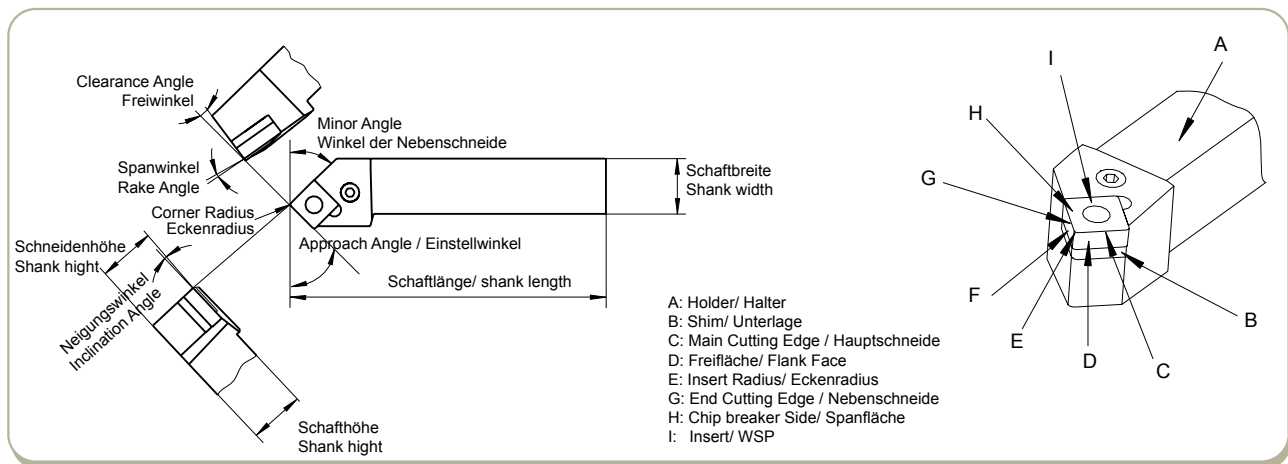

2. RAKE ANGLE · SPANWINKEL

Rake angle is a cutting edge angle that has large effects on cutting resistance, chip disposal, cutting temperature and tool life. Increasing rake angle in positive direction improves sharpness of the cutting edge and the cutting force decreases but at the same time it lowers the strength. To increase the cutting resistance the rake angle must be increased in negative direction.

Eine Vergrößerung des Spanwinkels reduziert Schnittkräfte, weil der Span wenig aus seiner Fließrichtung gelenkt wird. Hierdurch ist das Schneidensystem insgesamt schärfer und erzeugt dadurch eine geringere Schneidenbelastung, geringere Temperaturbelastung und insgesamt weniger Werkzeugverschleiß und somit eine hohe Zerspanungsleistung. Gleichzeitig bedeutet dies aber eine Schwächung des Schneidkeils, die Schneidenbelastung nimmt zu und die Gefahr von Schneidenausbrüchen steigt.

Selecting value	Auswahl	Specific machining situation	Anwendung
Small rake angle	Kleiner Spanwinkel	Machining of fragile and hard materials. Rough machining and interrupted cut	Bearbeitung von harten und spröden Werkstoffen Schruppbearbeitung und unterbrochener Schnitt
Big rake angle	Großer Spanwinkel	Machining of plastic materials and soft materials Precision machining	Bearbeitung von weichen und zähen Werkstoffen Präzisionsbearbeitung

3. RELIEF ANGLE · FREIWINKEL

Flank angle prevents friction between flank face and work piece resulting in smooth feed. Increasing flank angle decreases the cutting force and surface roughness becomes better but on the other hand this lowers the cutting edge strength and decrease the flank wear occurrence.

Eine Vergrößerung des Freiwinkels hat eine Verringerung der Reibung zwischen Werkstück und Werkzeug zur Folge. Die Schnittkräfte sind insgesamt geringer und es können bessere Oberflächengüten erreicht werden. Ein zu großer Freiwinkel schwächt allerdings die Schneidkantenstabilität. Je nach Anwendung liegen die Freiwinkel zwischen 3° und 12°.

Selecting value	Auswahl	Specific machining situation	Anwendung
Small flank angle	Kleiner Freiwinkel	Machining of hard and demure materials. For roughing operation with stable cutting edge	Bearbeitung von harten und spröden Werkstoffen Schruppbearbeitung mit stabiler Scheidkante
Big flank angle	Großer Freiwinkel	Precision machining with low cutting force Work pieces suffer from work hardening easily.	Für die Präzisionsbearbeitung, mit geringen Schnittkräften. Material das schnell zu Gefügeveränderungen neigt

4. INCLINATION ANGLE · NEIGUNGSWINKEL

The positive and negative edge inclined angle decides the discharging direction of chips. In heavy cutting, the cutting edge receives extremely large shock at the beginning of cutting. Cutting edge inclination keeps the cutting edge from receiving this shock and prevents fracturing. On the other hand the back force increases and occurs vibration.

A finishing operation a positive angle is more suitable. Shown on page 305 Picture (1), when the edge inclined angle is negative, i.e. the cutting edge is

located at the lowest point relative to the bottom plane of the tool holder, the chips flow to the machined surface of work piece. Shown on page 305 Picture (2), when the edge inclined angle is positive, i.e. the cutting edge is located at the highest point relative to the bottom plane of the tool holder, the chips flow to the un-machined surface of work piece.

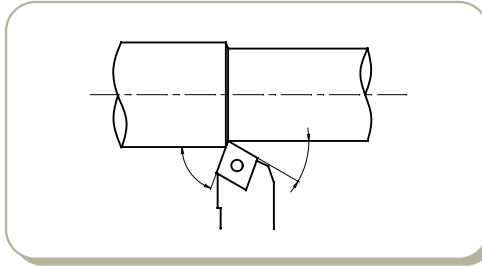

Die positive oder negative Anstellung der Schneidkante hat maßgeblichen Einfluß auf die Fließrichtung der Späne und die Belastung am Schneidpunkt.

Wie im Bild Seite 305 (1) dargestellt, bewirkt ein negativer Schneidkantenwinkel durch seinen zur Halteroberfläche niedrigeren Schneidpunkt einen Spanabfluß zur bereits bearbeiteten Werkstückoberfläche.

Wie im Bild Seite 305 (2) dargestellt bewirkt ein positiver Schneidkantenwinkel durch seinen zur Halteroberfläche höheren Schneidpunkt einen Spanabfluß zur un bearbeiteten Werkstückoberfläche.

Die Veränderung des Schneidkantenwinkels hat Einfluss auf die Stabilität der Schneide bzw. des Schneidpunktes. Diese wird

bei einem negativem Winkel erhöht und schützt somit das Werkzeug vor der Schlagbeanspruchung z.B. bei Schruppanwendungen oder Bearbeitungen mit unterbrochenem Schnitt.

Dabei wird aber auch die Gegenkraft erhöht, was zu Vibrationen führen kann.

Ein positiver Schneidkantenwinkel ist vorteilhaft bei der Schlichtbearbeitung, da die Späne von der bereits bearbeiteten Oberfläche weggeführt werden.

5. ENTERING ANGLE (APPROACH ANGLE) · EINSTELLWINKEL (HAUPTSCHNEIDE)

Reducing the lead angle increases the strength of the cutting edge. Heat dispersion is good and roughness of machining surface is small. Because lead angel is small, the cutting width is long, the force on the unit cutting edge length is small. At the same time, reducing the lead angle can increase the tool life.

Normally, when turn thin long shaft and ladder shaft, the lead angle adapts 90°. The lead angle is increased, radial force is reduced, cutting is stable, cutting thickness is increased and chip breaking performance is good.

Eine Reduzierung des Einstellwinkels erhöht die Stabilität der Schneide. Der Anteil der Schneide zur Spanbildung wird dabei vergrößert, die Belastung für die Schneide wird besser verteilt und die Wärme besser abgeführt. Ein kleiner Einstellwinkel wirkt sich positiv auf die Standzeit aus.

Ein großer Einstellwinkel von 90° wird bei der Bearbeitung von langen, dünnen Wellen benutzt, um eine Verbiegung des Werkstückes zu verhindern.

Selecting value	Auswahl	Specific machining situation	Anwendung
Small entering angle	kleiner Einstellw.	For material with high tensile strenght, high hardness or hardened layer on surface.	Für Materialien mit hoher Zugfestigkeit, hoher Härte oder gehärteter Oberfläche
Big entering angle	großer Einstellw.	For machine with low rigidity	Für Maschinen mit geringer Stabilität.

6. MINOR ANGLE · NEBENSCHNEIDENWINKEL

The minor cutting edge angle is the main angle on influence surface roughness; its size is also influence strength of cutter. When the minor cutting edge angle is too small, the cutting force increases and results in chattering and vibration.

The selection principle for the minor cutting edge angle is, under the condition of rough machining, or un-influencing friction and producing vibration, the smaller angle should be chosen; the bigger angle can be used for precision machining.

Die Größe des Nebenschneidenwinkels beeinflusst die Oberflächengüte des Werkstücks und auch die Schneidkantenstabilität. Ist der Winkel zu klein können Vibrationen auftreten.

Ein kleiner Winkel sollte daher bei der Schruppbearbeitung angewendet werden, da die Schneide eine höhere Stabilität aufweist. Für die Präzisionsbearbeitung mit hohen Oberflächengüten sollte ein möglichst großer Winkel gewählt werden.

7. CORNER RADIUS · EINSTELLWINKEL

The corner radius effects the cutting edge strength and the finished surface.

By increasing the corner radius the surface finish becomes better and the cutting edge strength improves. Flank and rake wear decreases. If the radius becomes to big cutting force increases and causes vibration. Also chip control becomes worth.

Die Größe des Nebenschneidenwinkels beeinflusst die Oberflächengüte des Werkstückes und auch die Schneidkantenstabilität. Ist der Winkel zu klein können Vibrationen auftreten. Ein kleiner Winkel sollte daher bei der Schruppbearbeitung angewendet werden, da die Schneide eine höhere Stabilität aufweist. Für die Präzisionsbearbeitung mit hohen Oberflächengüten sollte ein möglichst großer Winkel gewählt werden.

Selecting value	Auswahl	Specific machining situation	Anwendung
Small corner radius	Kleiner Radius	<ul style="list-style-type: none"> Finishing with small cutting depth Machining thin long shafts Rigidity of machine is insufficient 	<ul style="list-style-type: none"> Schlichtbearbeitung mit kleinen Schnitt-tiefen Bearbeitung von langen, dünnen Wellen Geringe Maschinenstabilität oder Spannung
Big corner radius	Großer Radius	<ul style="list-style-type: none"> Rough machining, high cutting edge strength is required Rigidity of machine is good Machining harden materials and interrupted cut 	<ul style="list-style-type: none"> Schruppbearbeitung mit hoher Schneidkantenstabilität Hoher Maschinenstabilität Bearbeitung mit unterbrochenem Schnitt oder Schmiedehaut

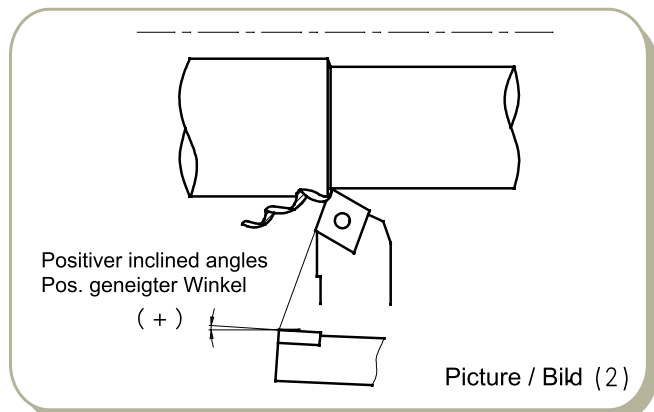
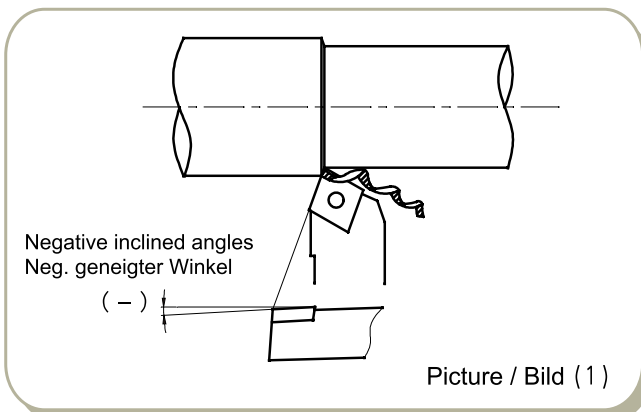

1. CUTTING SPEED · SCHNITTGESCHWINDIGKEIT

$$V_c = \frac{\pi \times D \times n}{1000} \quad (m/min)$$

V_c: Cutting Speed/ Schnittgeschwindigkeit (m/min)

n: Revolution per min (rev/min)/ Drehzahl (U/min)

f: Feed per revolution (mm/rev)/ Vorschub pro Umdrehung (mm/U)

Example/Beispiel: n=250 U/min, f=0,2 mm/U, l=150mm

Result/Ergebnis: [hier dann die Formel V_c=...]

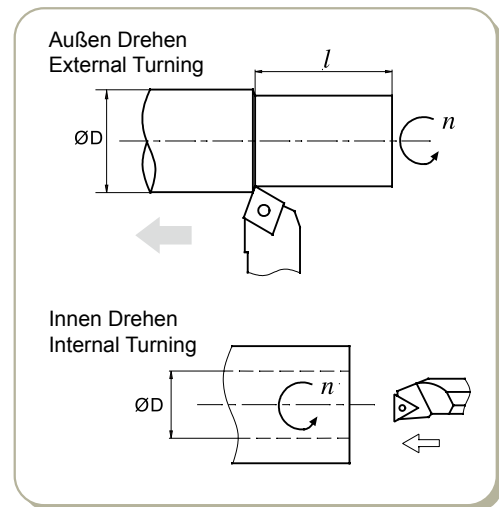

2. FEED RATE · VORSCHUBSGESCHWINDIGKEIT (F)

$$f = \frac{l}{n} \quad (mm/rev)$$

f: Feed per Revolution/ Vorschub pro Umdrehung (mm/U)

l: Cutting length per Min/ Schnittlänge pro Minute (mm)

n: Revolution per min (rev/min)/Drehzahl (U/min)

Example/Beispiel: n=500 U/min, l=100 mm/min

Result/ Ergebnis: [hier dann die Formel f=.....]

$$f = \frac{l}{n} = \frac{100}{500} = 0.2 (mm/rev)$$

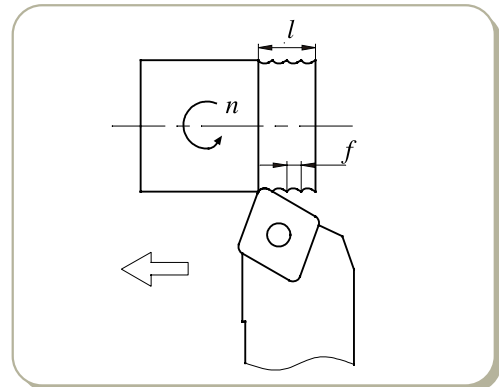

3. CUTTING TIME · SCHNITTZEIT

$$T_c = \frac{l}{f \times n} \text{ (min)}$$

T_c: Cutting Time/ Schnittzeit (min)

l: Cutting length per Min/ Schnittlänge pro Minute (mm)

f: Feed per revolution (mm/rev)/ Vorschub pro Umdrehung (mm/U)

n: Revolution per min (rev/min)/ Drehzahl (U/min)

Example/Beispiel: n=250 U/min, f=0,2 mm/U, l=150mm

Result/Ergebnis: [hier dann die Formel T_c=...]

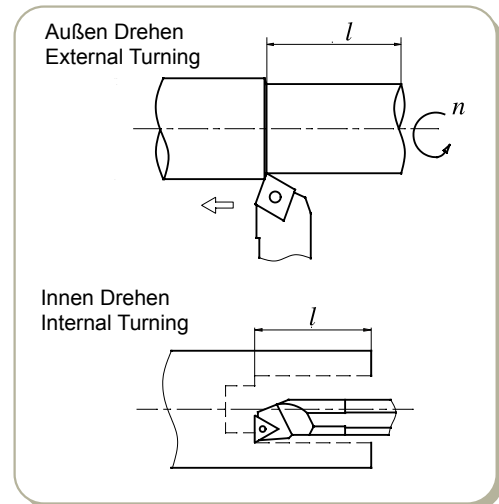

4. CUTTING TIME · SCHNITTZEIT FÜR PLANBEARBEITUNG

$$T_c = \frac{\pi \times (a^2 - b^2)}{4000 \times V_c \times f} \text{ (min)}$$

T_c: Cutting Time/ Schnittzeit (min)

V_c: Cutting Speed/ Schnittgeschwindigkeit (m/min)

f: Feed per revolution (mm/rev)/ Vorschub pro Umdrehung (mm/U)

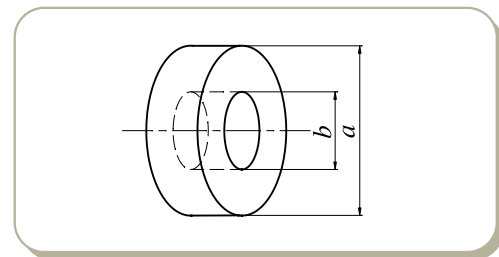

5. THEORETICAL SURFACE ROUGHNESS · THEORETISCHE OBERFLÄCHEN-RAUHIGKEIT (R)

$$R = \frac{f^2}{8r_c} \times 1000 \text{ (}\mu\text{m)}$$

R: Surface Roughness/Oberflächenrauigkeit (μm)

f: Feed per revolution (mm/rev)/ Vorschub pro Umdrehung (mm/U)

r_c: Insert Radius/ Radius des WSP (mm)

Example/Beispiel: f=0,2 mm/U, r_c=0,4 mm

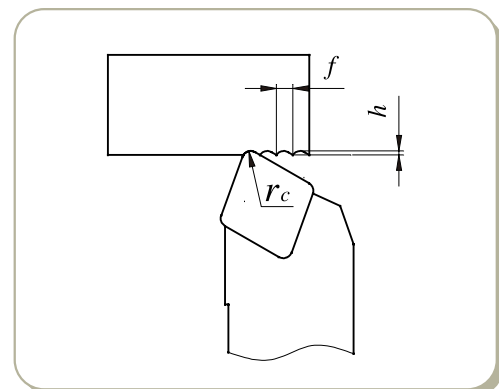

Three effects of cutting condition for turning Einfluss der drei Schnittparameter beim Drehen

Three effects of cutting Die drei Einflussgrößen

Today short machining time, long tool life and high machining accuracy is expected from modern tools. Based on the machine performance, material shape and hardness of the components the right choice of tool and cutting conditions are the premise for a successful machining process. Cutting speed, feed rate and depth of cut we call the "Three effects of cutting".

Die heutigen Anforderungen an moderne Zerspanungswerkzeuge sind in erster Linie kurze Bearbeitungszyklen, lange Werkzeugstandzeiten und hohe Bearbeitungsgenauigkeit.

In Abhängigkeit z.B. der Maschinenleistung, Material, Form und Härte des Werkstückes ist die Wahl der Werkzeuge und vor allem die richtigen Schnittparameter Voraussetzung

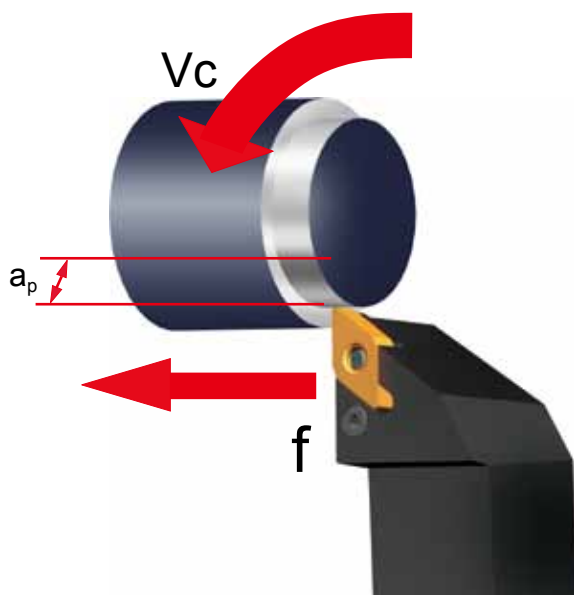

für eine wirtschaftliche Zerspanung. Dieses nennen wir den „Einfluss der drei Schnittparameter beim Drehen“

Cutting speed · Schnittgeschwindigkeit (Vc)

Cutting speed is defined as the rate (or speed) that the material moves past the cutting edge of the tool. The unit for Vc is meter per minute [m/min].

Die Schnittgeschwindigkeit ist die Geschwindigkeit, mit der eine Werkzeugschneide in Schnittrichtung durch den zu bearbeitenden Werkstoff geführt wird und somit einen Span abnimmt. Die Einheit wird in Meter pro Minute [m/min] angegeben.

Cutting speed influence · Einfluss der Schnittgeschwindigkeit

Cutting speed is one of the three important effects of turning and has influence on tool life. Increasing the cutting speed also increases the cutting temperature and that decreases the tool life. Depending on the hardness and type of material the cutting speed varies. Therefore to choose a suitable grade for the cutting speed is necessary.

In general situation, when cutting speed is increased by 20% the tool life will be reduced 1/2; when the cutting speed is increased by 50% the tool life decreases 1/5

Lower cutting speed results in vibration which will shorten tool life.

Die Schnittgeschwindigkeit ist eine der wichtigsten Größen bei der Zerspanung, denn sie beeinflusst entscheidend die Fertigungszeit. Die Wahl der Schnittgeschwindigkeit hängt im Wesentlichen von der Zusammensetzung und Festigkeit des zu bearbeitenden Werkstoffes, der Zähigkeit und Härte des eingesetzten Schneidstoffes sowie

der gewünschten Maßgenauigkeit und Oberflächengüte ab. Sie beeinflusst aufgrund des parabolischen Anstiegs der Schneidentemperatur bei steigender Geschwindigkeit wesentlich den Verschleiß und somit die Standzeit des Werkzeuges. Die Schnittgeschwindigkeit ist daher so zu wählen, dass ein günstiges Verhältnis zwischen der Arbeits- und Schnittzeit und der für die Wiederinstandsetzung (Wechsel der Wendeschneidplatte) des Werkzeuges und Neueinrichten der Bearbeitungsmaschine erforderlichen Zeit entsteht.

Erhöhung V_c um 20% verringert die Standzeit auf die Hälfte; Erhöhung V_c um 50% beträgt die Standzeit nur noch ca. 1/5.

Geringes V_c führt zu Vibrationen und verkürzt die Standzeit.

Feed rate · Vorschub (f)

In turning application feed rate is the distance the tool holder moves per work piece revolution. That has influence to the surface quality. The unit for feed rate is millimetre per revolution [mm/rev]

Bei der Drehbearbeitung versteht man unter dem Vorschub den zurückgelegten Weg des Werkzeug(-halters) pro Umdrehung des Werkstückes und hat Einfluss auf die Oberflächengüte des Werkstückes. Die Einheit des Vorschubes ist Millimeter pro Umdrehung [mm/U]

Feed rate influence · Einfluss des Vorschubes

Decreasing the feed rate will increase flank wear and tool life will be shorten. Increasing feed rate increases the cutting temperature and also flank wear. On the other hand the efficiency will be improved.

Bei einer Reduzierung des Vorschubes steigt gleichzeitig der Freiflächenverschleiß an und die Standzeit des Werkzeuges wird herabgesetzt. Bei einer Erhöhung des Vorschubes steigt zwar die Wirtschaftlichkeit der Bearbeitung, allerdings auch die Schnitttemperatur und die Verschleißgröße.

Depth of cut (doc) · Schnitttiefe (ap)

The depth of cut refers to the half different value between the diameter of the unmachined and machined work piece. The unit is millimeter [mm]

Die Schnitttiefe ist die halbe Differenz des Rohteildurchmessers zum gefertigten Durchmesser des Werkstückes. Die Einheit der Schnitttiefe ist Millimeter [mm].

Depth of cut influence · Einfluss der Schnitttiefe

Changing depth of cut has no big influence to the tool life. Machining hardened layer with small depth of cut results in friction and short tool life. Machining uncut surface or cast iron material, choose maximum depth of cut according to the machine power so that the cutting edge and corner radius is out of the hardened layer. That helps to prevent chipping and abnormal wear.

